



**Fisher Engineering**

P.O. Box 529 Rockland, Maine 04841

**Light Kits**

**7-Pin**

**9-Pin**

**12-Pin**

**8418**

**8416-1/8416**

**8417**

March 12, 1999

No. 6431



# **7-Pin, 9-Pin, and 12-Pin Light Kits Parts List and Installation Instructions**

## **Table Of Contents**

<b>Safety .....</b>	<b>2</b>
<b>Light Kit Diagram .....</b>	<b>2</b>
<b>Light Kit Parts List .....</b>	<b>3</b>
<b>Snowplow Light Installation .....</b>	<b>4</b>
<b>Vehicle Harness Installation .....</b>	<b>5</b>
<b>Peculiar Light Harness Installation .....</b>	<b>6</b>
<b>Relay Connections/System Diagram</b>	
<b>7-Pin .....</b>	<b>9</b>
<b>9-Pin .....</b>	<b>10</b>
<b>12-Pin .....</b>	<b>11</b>
<b>Headlamp Beam Aiming .....</b>	<b>12</b>



**SAFETY INFORMATION**

**⚠ WARNING**  
Indicates a potentially hazardous situation that may result in death or serious injury if not avoided.

**⚠ CAUTION**  
Indicates a potentially hazardous situation that may result in minor or moderate injury and/or property damage if not avoided.

**NOTE:** Identifies tips, helpful hints and maintenance information the owner/operator should know.

Torque all fasteners according to the torque chart. For proper fit, do not tighten fasteners until instructed to do so.

NC FASTENER TORQUE (FT-LB)			
DIAMETER- THREADS PER INCH	GRADE		
			
1/4 - 20	6	9	13
5/16 - 18	11	18	28
3/8 - 16	19	31	46
7/16 - 14	30	50	75
1/2 - 13	45	75	115
9/16 - 12	66	110	165
5/8 - 11	93	150	225
3/4 - 10	150	250	370
7/8 - 9	150	378	591
1 - 8	220	583	893

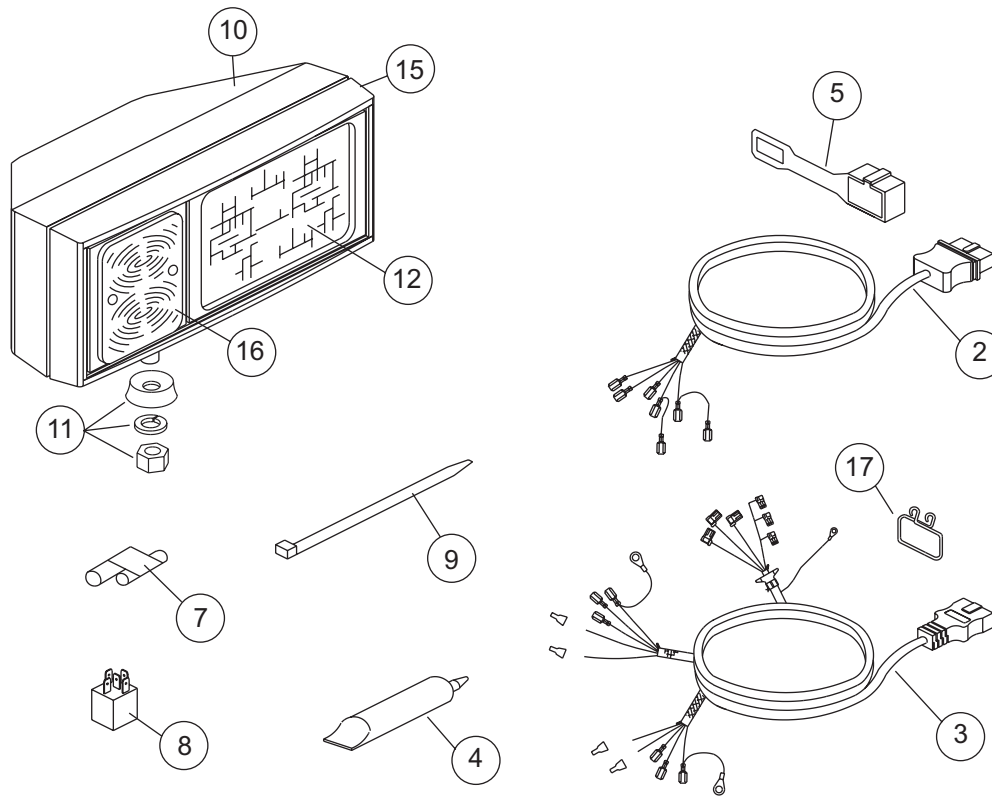

<b>8418, 8416-1/8416, 8417 Light Kits</b>					
Ref #	Part #	Description	Quantities		
			7-Pin	9-Pin	12-Pin
n/s		Peculiar Light Harness – check the Kit Selection Guide for proper application.	1	1	1
2	8611	Vehicle Harness – 7-Pin (Belt Drive)	1		
	8275	Vehicle Harness – 9-Pin (SEHP)		1	
	8276	Vehicle Harness – 12-Pin (SEHP/Belt Drive)			1
3	8612	Snowplow Harness Kit – 7-Pin (Belt Drive)	1		
	8246	Snowplow Harness Kit – 9-Pin (SEHP)		1	
	21293	Snowplow Harness Kit – 9-Pin (Insta-Act® Hydraulics)		1	
	8273	Snowplow Harness Kit – 12-Pin (SEHP)			1
	21713	Snowplow Harness Kit – 12-Pin (Insta-Act Hydraulics))			1
4	8329K	Dielectric Grease	1	1	1
5	8291	Plug Cover	1	2	2
7	5776	Bullet Receptacle Cover	3	3	3
8	8293	Headlamp Relay	2	2	3
9	3666	Cable Tie	8	8	8
10	8328	Replacement Headlamp (Drive or Passenger Side)	1	1	1
11	6128	Headlamp Swivel and Fasteners	1	1	1
12	6728	2E1 Sealed Beam Light – Plastic Halogen Type	2	2	2
n/s	6664	Sealed Beam Gasket Set (1 pair)	1	1	1
n/s	A6153	2E1 Retainer Fingers with Screws (4 each)	1	1	1
15	6122	Bezel with Fasteners (Driver or Passenger Side)	1	1	1
16	6123	Park/Turn Lens with Fasteners (Driver or Passenger Side)	1	1	1
n/s		Park/Turn Signal Bulb (Trade No. 115)	4	4	4
17	20128	Hook	1	1	1
n/s	8704	Ring Terminal			1
n/s	8738	Butt Connector – Heat Shrink			1
ns = not shown					

## SNOWPLOW LIGHT INSTALLATION

### ⚠ WARNING

Your vehicle must be equipped with snowplow headlights and directional lights.

1. Attach the snowplow lights with harness to the headgear with the park/turn lights to the outside. Route the snowplow harness down the driver-side upright to match the vehicle harness plug. After installation is completed, aim the headlamps per instructions on page 12.

**9-Pin and 12-Pin Harnesses Only:** Remove the plastic cover from the valve block assembly and install the solenoid wires according to the instructions inside the cover. With the strain relief inside, install the cover. Route the black/orange wire to the motor ground and connect.

**12-Pin Belt Drive with DRLs:** Go to page 8.

2. Secure the harness to the headgear with cable ties.
3. Install the hook as shown.

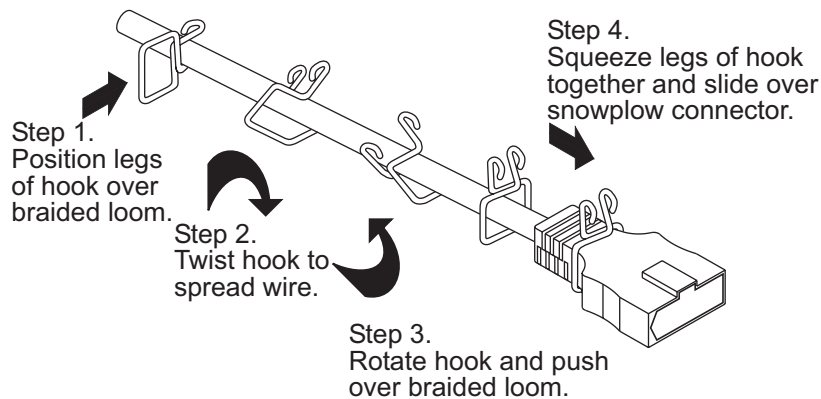
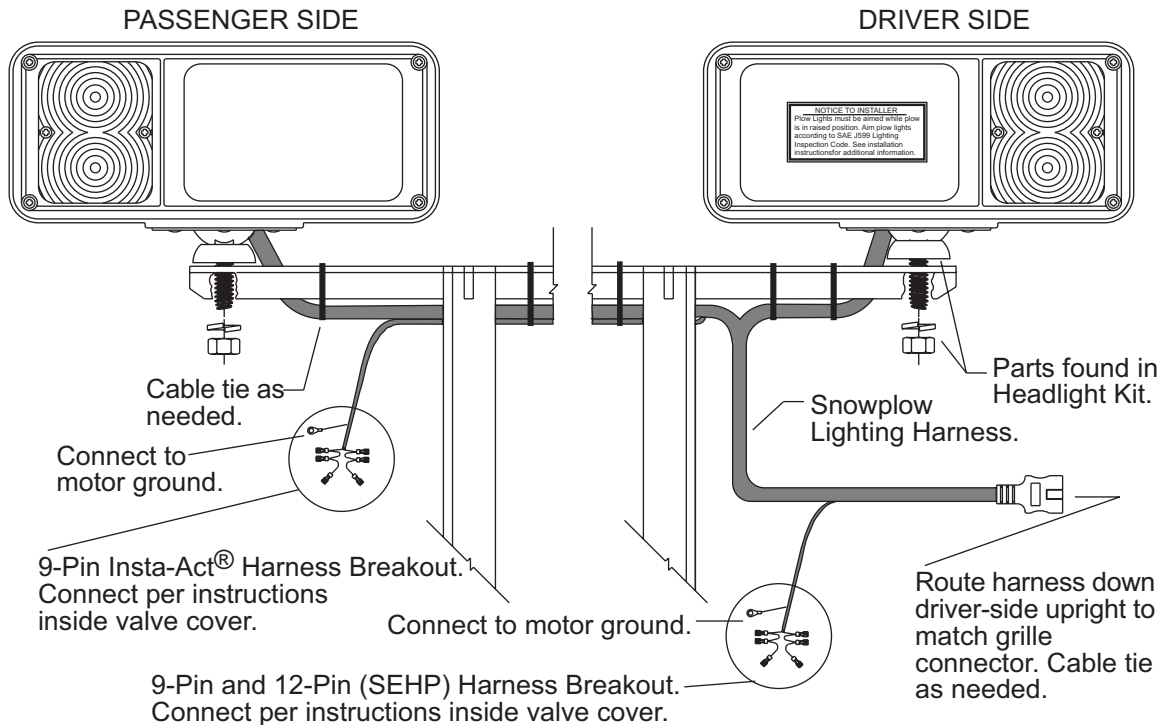

## VEHICLE HARNESS INSTALLATION

**NOTE: Removal of vehicle grille may aid in the vehicle and peculiar harness installation.**

**NOTE: Use dielectric grease (4) to prevent corrosion of all electrical connections. Fill receptacles and lightly coat ring terminals and blades before assembly.**

1. Stretch the rectangular opening of the plug cover strap (5) over the grille plug end of the vehicle harness (2). Place the plug cover over the molded grille plug on the harness.
2. Select a location at a convenient height in driver-side grille for the connection to the snowplow plug.
3. If a grille plate is supplied for this vehicle, slide the groove of the grille connector into the grille plate. If a grille plate is not included, allow enough cable to hang out in front of the grille for easy connecting and removal of the snowplow plug.

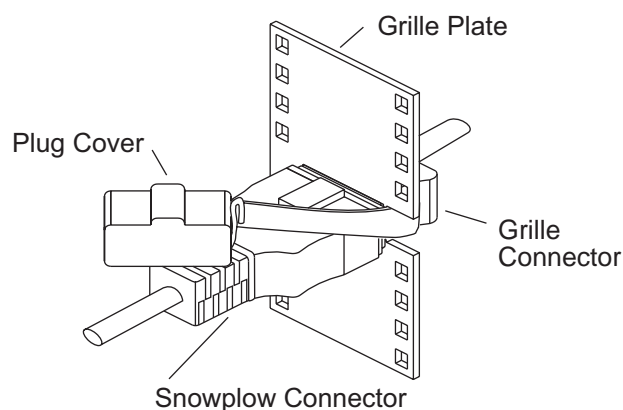
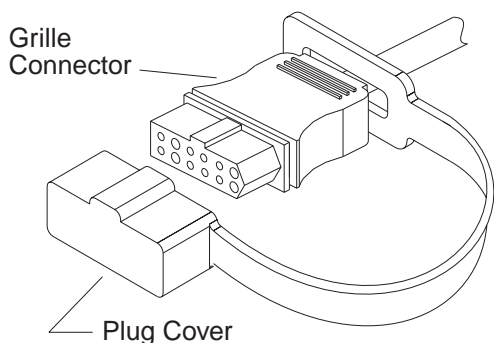

4. Route the vehicle harness through the selected location in the grille and through, or around, the radiator bulkhead into the engine compartment behind the driver-side headlamp(s).
5. If a grille plate is used, use cable ties (9) to secure grille plate to the grille.

**7-Pin Harness Only:** Connect the ring terminal on the orange/black wire to a good vehicle ground.

6. After connecting the snowplow plug with the grille connector, stretch the plug cover over the legs of the hook as shown.

**For 1988-95 CHEVY/GMC C/K Vehicles:** Go to page 7.

For all other vehicles, continue below.

7. On the driver side of the vehicle, identify the left turn signal wire and parking lamp wires. Attach a black bullet receptacle connector (7) to each wire.
8. Identify the right turn signal wire on the passenger side of the vehicle. Attach a black bullet receptacle connector to this wire.
9. On the driver side of the vehicle, insert the gray and brown wire bullets into the black bullet receptacles with the gray wire to turn signal and the brown wire to park lamp.
10. Connect the wires with the 1/4" receptacles to the headlamp relays (8) behind the driver-side headlamp(s) as shown on the following pages. Installation of the vehicle harnesses for the 12-pin belt drive and 7-pin harness applications are complete.

**For 9-Pin and 12-Pin Harnesses Only:**

**⚠ CAUTION**

**Check for wires, hoses or any other obstructions on both sides of the fire wall before drilling.**

11. Drill a 5/8" hole in a convenient location on the fire wall.
  12. Route the vehicle harness through the hole in the fire wall. Feed the fuse holder through first, then the plastic connector and harness.
  13. Connect the red wire from the fuse holder to a circuit which is on only when the ignition key is on. Use the supplied fuse taps and insulated receptacles.
  14. In the engine compartment, route the brown/red wire and the orange/black wire to the motor relay. Attach the ring terminals to the small motor relay terminals with 10-32 nuts and lock washers. Connect the 24" orange/black wire to the negative terminal on the battery.
  15. Place a grommet around the harness and insert it into the firewall. Use cable ties to secure harness and wires away from any sharp, hot or moving parts.
- 

## PECULIAR HARNESS INSTALLATION INSTRUCTIONS

---

**NOTE: Use dielectric grease (4) to prevent corrosion of all electrical connections. Fill receptacles and lightly coat ring terminals and blades before assembly.**

---

1. Starting on the driver side, remove headlamp connector(s), connect the peculiar harness male connector(s) to the female connector(s) removed from the headlamp(s). Connect the peculiar harness female connector(s) to the headlamp(s). For 2E Type headlamps, see illustration on page 7.
  2. Route the other end of the harness along the radiator bulkhead, or over the radiator shroud, to the passenger-side headlamp(s).
  3. On the passenger side, remove the headlamp connector(s) and connect the peculiar harness female connector(s) to the headlamp(s). Connect the peculiar harness make connector, if supplied, to the female connector removed from the headlamp. Secure any unused connectors with cable ties.
  4. Insert the purple wire bullet into the black bullet receptacle on the passenger-side turn signal wire.
  5. Insert the purple wire bullet from the vehicle harness into the purple wire receptacle on the peculiar harness.
  6. Connect the remaining wires on the driver side to the headlamp relays (8) as shown on pages 9--11.
  7. Use cable ties to secure the relays and prevent accidental grounding of any connections. Cable tie any harnesses and wires away from hot or moving engine parts.
  8. Replace the vehicle turn signal flasher if one is included in the peculiar harness kit (6).
- 
- NOTE: Pre-1995 vehicles may experience rapid turn signal flashing (greater than 120 flashes/minute). A heavy duty flasher needs to be installed if this occurs.**
- 

9. Reinstall grille. Aim headlamps according to the instructions on page 12 if not already completed.

## INSTRUCTIONS FOR VEHICLES WITH 2E TYPE HEADLAMPS

**NOTE: For installation on Dodge Dakota, 94-96 Chevy S10 and GMC Sonoma without DRL's and 95-96 Blazer/Jimmy with two headlights.**

On vehicles equipped with 2E type headlamps (SAE type 2E, 4" x 6-1/2" rectangular). Insert wires as shown in the diagrams when instructed to couple male connectors with vehicle headlamp connectors in steps 1 and 3 on page 6.

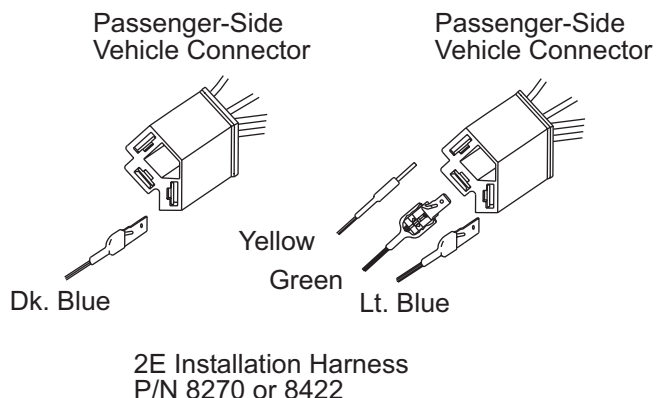

## FOR 88-95 CHEVY/GMC C/K ONLY

**NOTE: 1988-1995 Chevy/GMC C/K vehicles require snowplow turn signal relays for reliable hazard/stoplight operation. Without them, the additional amperage may blow the hazard/stoplight fuse.**

The following instructions are for the relays supplied in the snowplow prep kit which are mounted on either side of the radiator support. If the vehicle is not so equipped, they may be installed per the appropriate GM Service Bulletin or FISHER® Relay Kit 8035 may be installed per the instructions in that kit.

If the FISHER Relay Kit 8035 is used, install this light kit per the instructions for "all vehicles except Chevy/GMC C/K" and then install and connect the relay kit 8035.

1. On the driver side of the vehicle, identify the light blue left turn signal wire from the relay and the parking lamp wire. Attach a black bullet receptacle connector (7) to each wire. Position the bullet receptacle to cover the end of the wire from the relay.
2. On the passenger side of the vehicle, identify the dark blue right turn signal wire from relay. Attach a black bullet receptacle connector (7) to this wire. Position the bullet receptacle to cover the end of the wire from the relay.

3. If not already installed, install a 7-pin, 9-pin, or 12-pin vehicle harness. (2).
4. On the driver side of the vehicle, insert the gray and brown wire bullets into the black bullet receptacles, gray to Lt. blue wire from the relay, brown to park lamp wire.
5. On the passenger side, insert purple wire bullet into black bullet receptacle on dark blue wire from relay.
6. Insert purple wire bullet from 7-pin, 9-pin, or 12-pin vehicle harness into purple wire receptacle on peculiar harness.
7. Connecting power to turn signal relays: Locate relay power lead, two red wires with gray fusible link with eye terminal near fire wall on driver side. Route to battery junction block and connect to a positive terminal.
8. Use cable ties to secure relays and prevent accidental grounding of connections. Tape and secure any unused wires, cable tie harnesses and wires away from hot or moving engine parts.
9. Complete step 10 on page 5.

### SNOWPLOW HARNESS - FOR 12-PIN BELT DRIVE WITH DRLs ONLY

1. Cut black/orange wire 2" from braiding. Discard terminals.
2. Cut off blue wire terminal next to terminal.
3. Cut green and white/yellow to same length as blue wire.
4. Strip blue, green, and white/yellow wire insulation 1/4" from ends of wires. Twist ends of three wires together. Insert into one end of butt splice and crimp in place. Make sure the wire is properly seated, make the crimp connection using a tool designed for insulated splices.
5. Remove ring terminal and 3" to 4" of black/orange wire. Strip insulation 1/4" from end of wire. Insert black/orange wire into open end of butt splice and crimp in place.
6. Bend over ears on strain relief. Apply heat directly to the splice, working from the center out to the edges, using a hot air gun or other heat source, until the tubing recovers and the adhesive flows. Allow to cool before inspecting splice and checking integrity.
7. After modification of the harness, go to page 4, step 2.

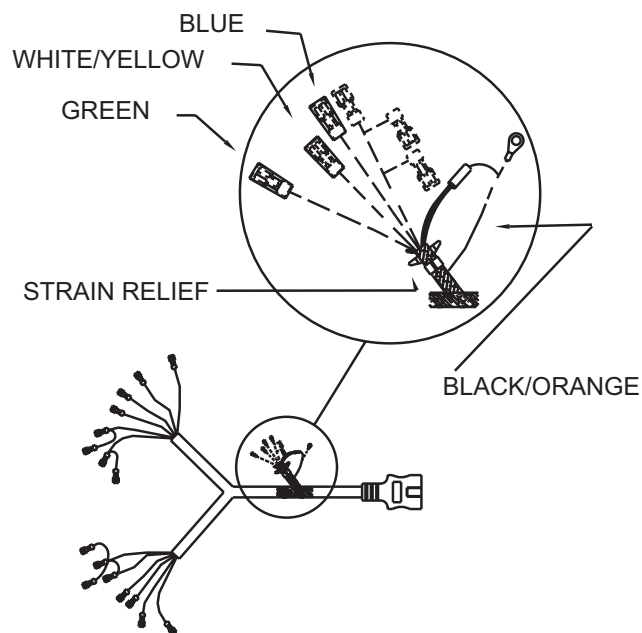

### VEHICLE HARNESS

1. Determine the length of wire required to go from left vehicle headlamp to a good ground. Cut harness at required length (usually 24") from loose wires.
2. Slide braiding back 4" to 6" from cut end of harness.
3. Cut both black/orange wires next to braiding.
4. Strip blue, green, and white/yellow wire insulation 1/4" from ends of wires.
5. Twist ends of three wires together and crimp in furnished ring terminal.
6. Slide braiding back over wires and tape with electrical tape.
7. After modification of the harness, go to page 5, step 1.

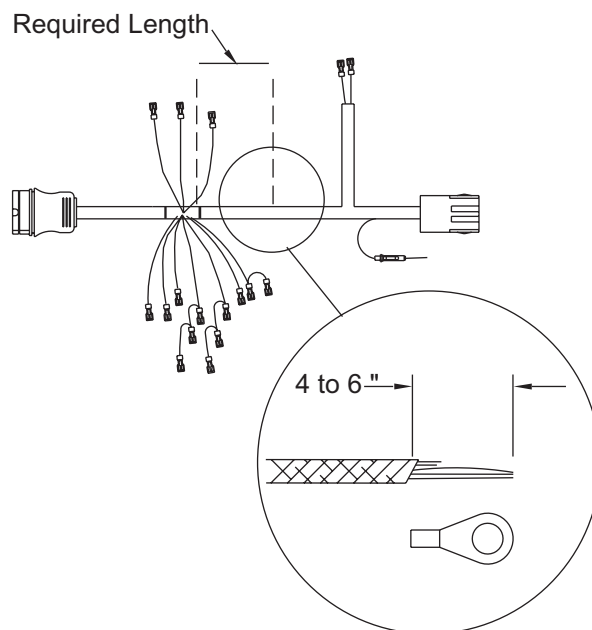



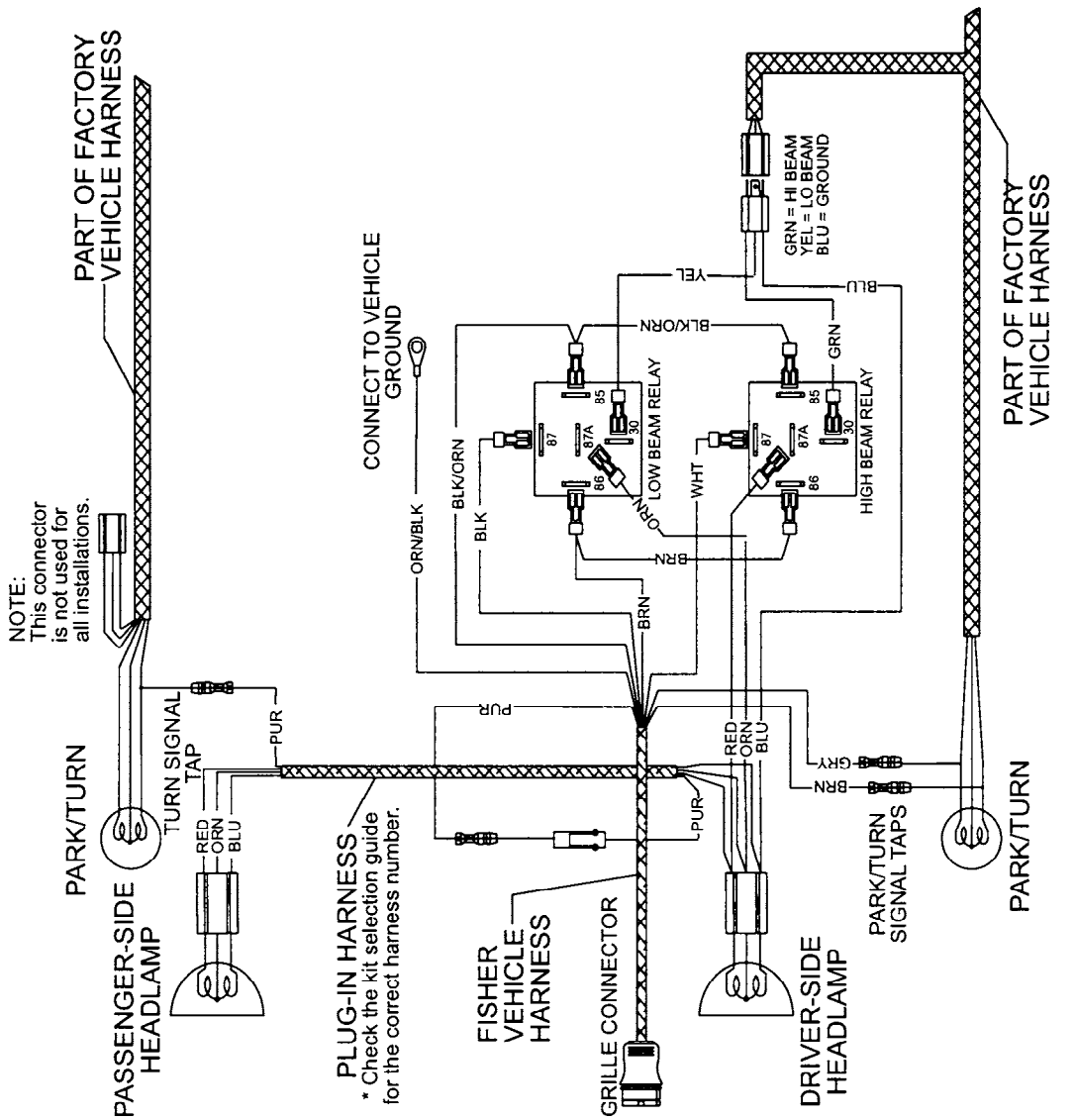

TYPICAL 7 PIN VEHICLE HARNESS INSTALLATION

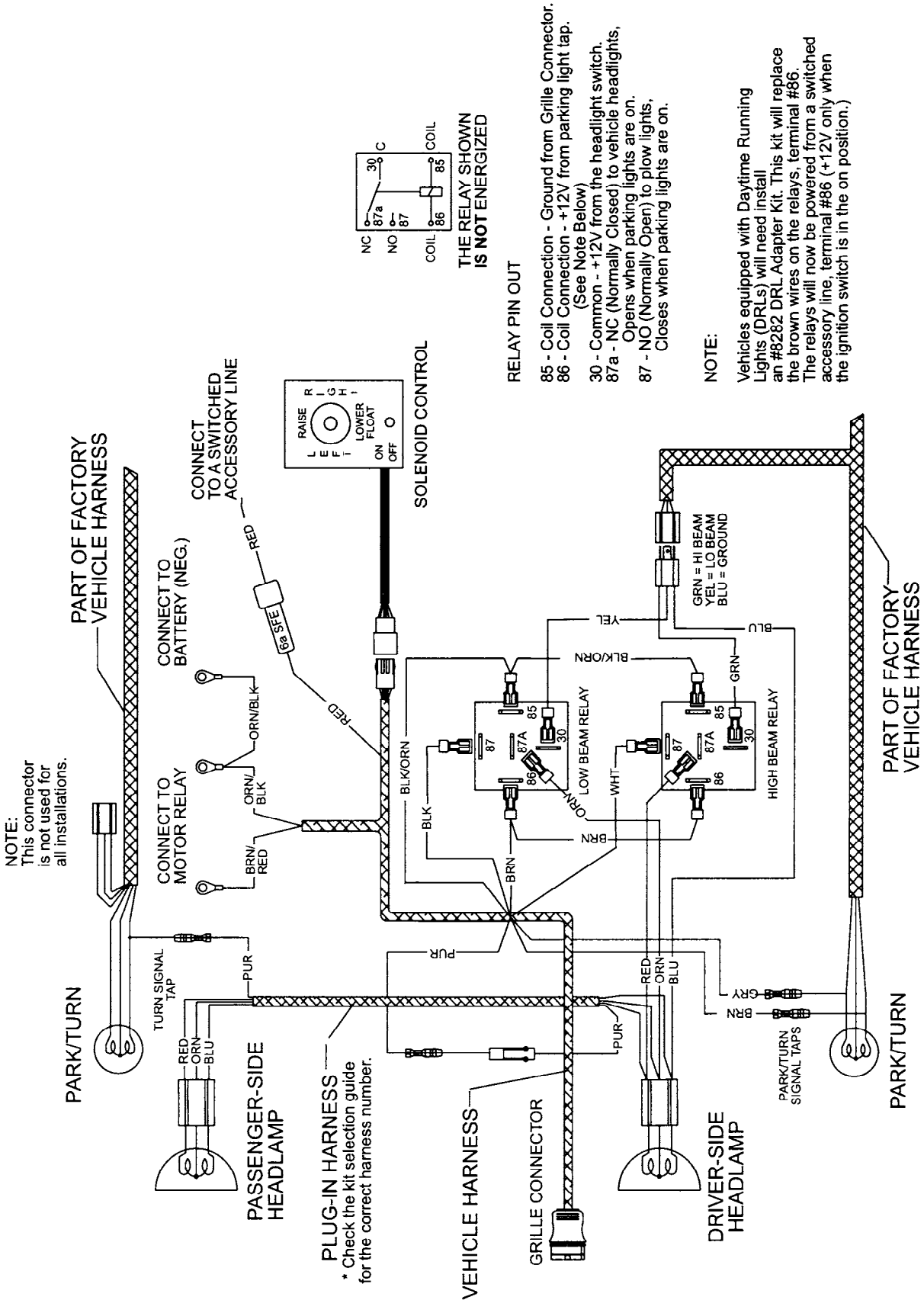

TYPICAL 9 PIN VEHICLE HARNESS INSTALLATION

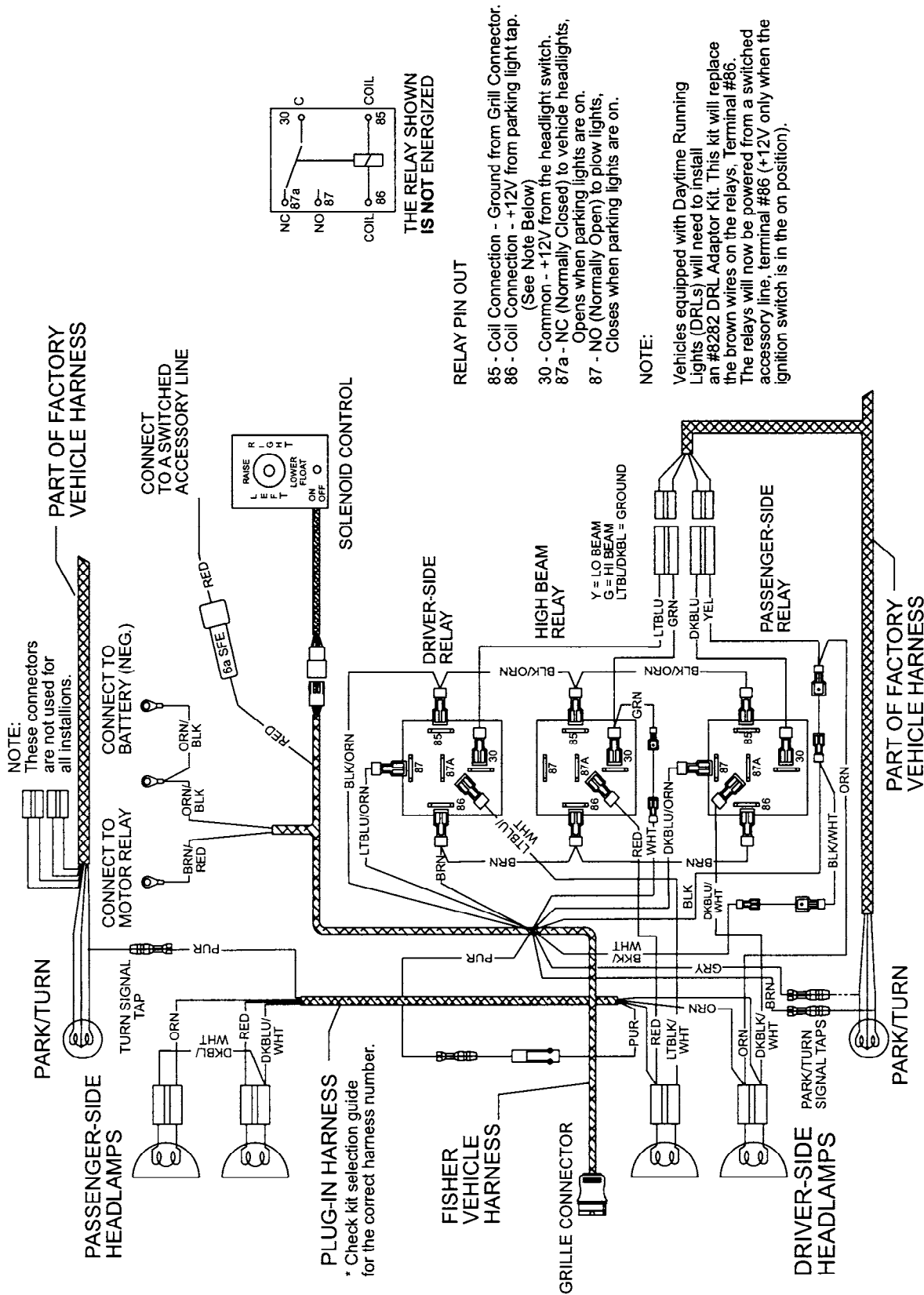

TYPICAL 12 PIN VEHICLE HARNESS INSTALLATION

## HEADLAMP BEAM AIMING

1. Place vehicle on a level surface 25 feet in front of a matte-white screen, such as a garage door. The screen should be perpendicular both to the ground and to the vehicle center line.
2. The vehicle should be equipped for normal operation, the snowplow blade should be in place and in raised position. Below are steps listed by the Society of Automotive Engineers (SAE) pertinent to headlamp aiming in specification #SAE J599d.
3. Prepare vehicle for headlamp aim or inspection. Before checking beam aim, the inspector will:
  - a. Remove ice or mud from under fenders.
  - b. See that no tire is noticeably deflated.
  - c. Check springs for sag or broken leaves.
  - d. See that there is no load in the vehicle other than the driver.
  - e. Check functioning of any "level-ride" control.
4. Mark (or tape) the vertical centerline of the headlamps and the vehicle itself on the screen. Mark the horizontal centerline of the headlamps on the screen (distance from ground to headlamp centers).
5. The correct visual aim for type 2 headlamps (snowplow headlamps are type 2; see number on face of sealed beam) is with the top edge of the high intensity zone of the lower beam below the horizontal centerline and the left edge of the high intensity zone on the vertical centerline (see diagram below).
- f. Check lens and aiming pad.
- g. Check for bulb burnout, broken mechanical aiming pads, and proper beam switching.
- h. Stabilize suspension by rocking vehicle sideways.

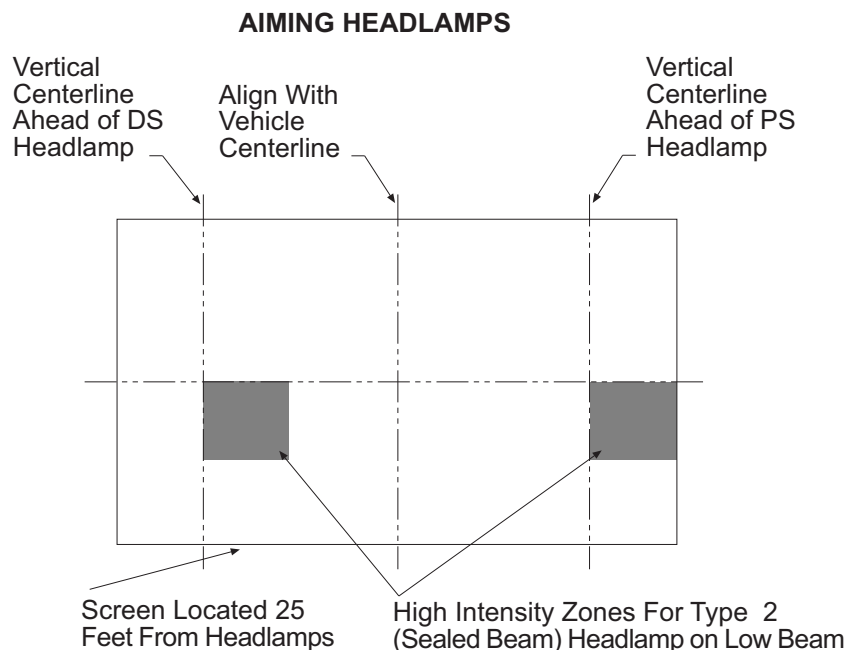

**dd** A DIVISION OF DOUGLAS DYNAMICS, L.L.C.

Copyright © 1999 Douglas Dynamics, L.L.C. All rights reserved. This material may not be reproduced or copied, in whole or in part, in any printed, mechanical, electronic, film or other distribution and storage media, without the written consent of Fisher Engineering. Authorization to photocopy items for internal or personal use by Fisher Engineering outlets is granted.

Fisher Engineering reserves the right under its product improvement policy to change construction or design details and furnish equipment when so altered without reference to illustrations or specifications used herein. Fisher Engineering and the vehicle manufacturer may require and/or recommend optional equipment for snow removal. Fisher Engineering offers a limited warranty for all snowplows and accessories. See separately printed page for this important information. The following are registered (®) and unregistered (™) trademarks of Douglas Dynamics, L.L.C.: FISHER®, Minute Mount®, Insta-Act®

Printed in USA