

8843 - VALVE ASSEMBLY

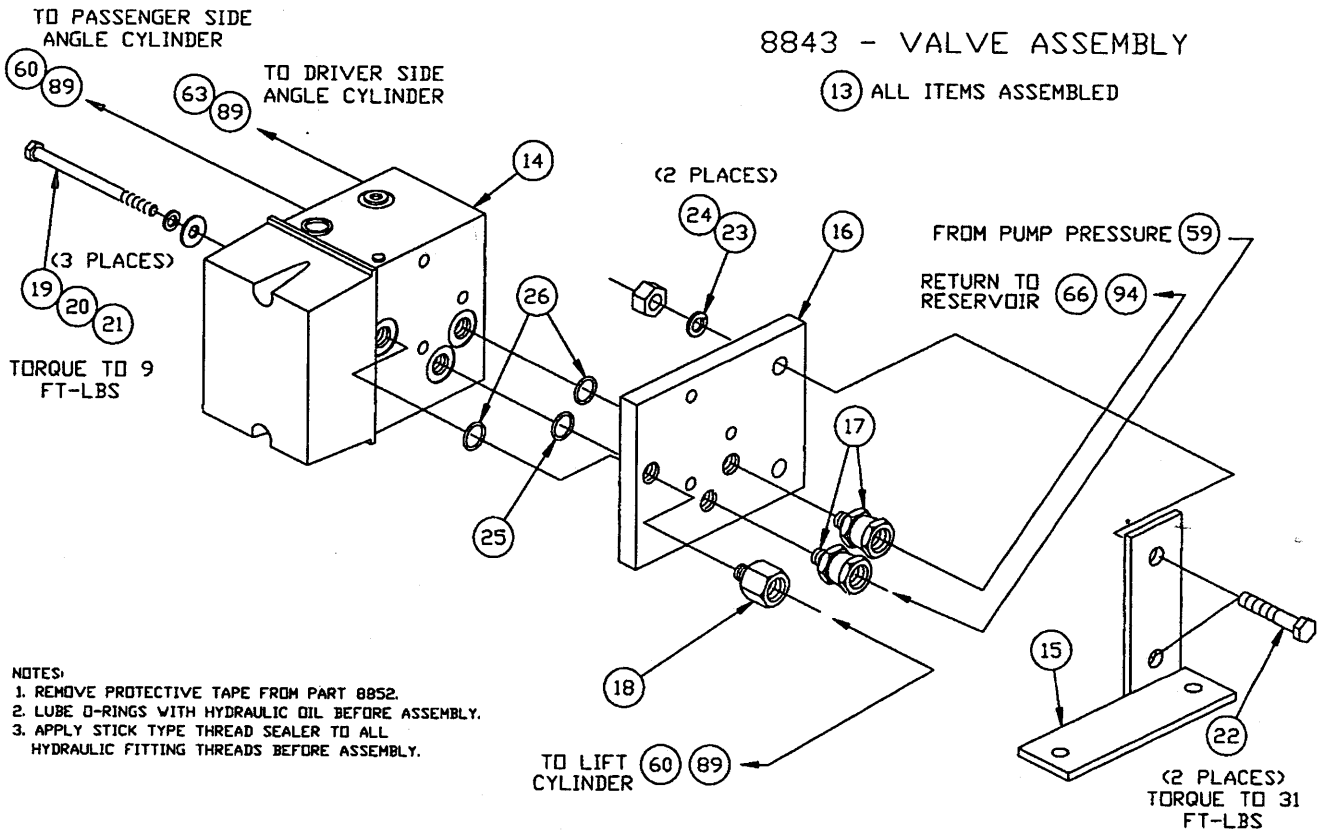

NOTES:

1. REMOVE PROTECTIVE TAPE FROM PART 8852.
2. LUBE O-RINGS WITH HYDRAULIC OIL BEFORE ASSEMBLY.
3. APPLY STICK TYPE THREAD SEALER TO ALL HYDRAULIC FITTING THREADS BEFORE ASSEMBLY.

21220 PUMP-CLUTCH ASSEMBLY

NOTES:

1. APPLY STICK TYPE THREAD SEALER TO ALL HYDRAULIC FITTING THREADS BEFORE ASSEMBLY.

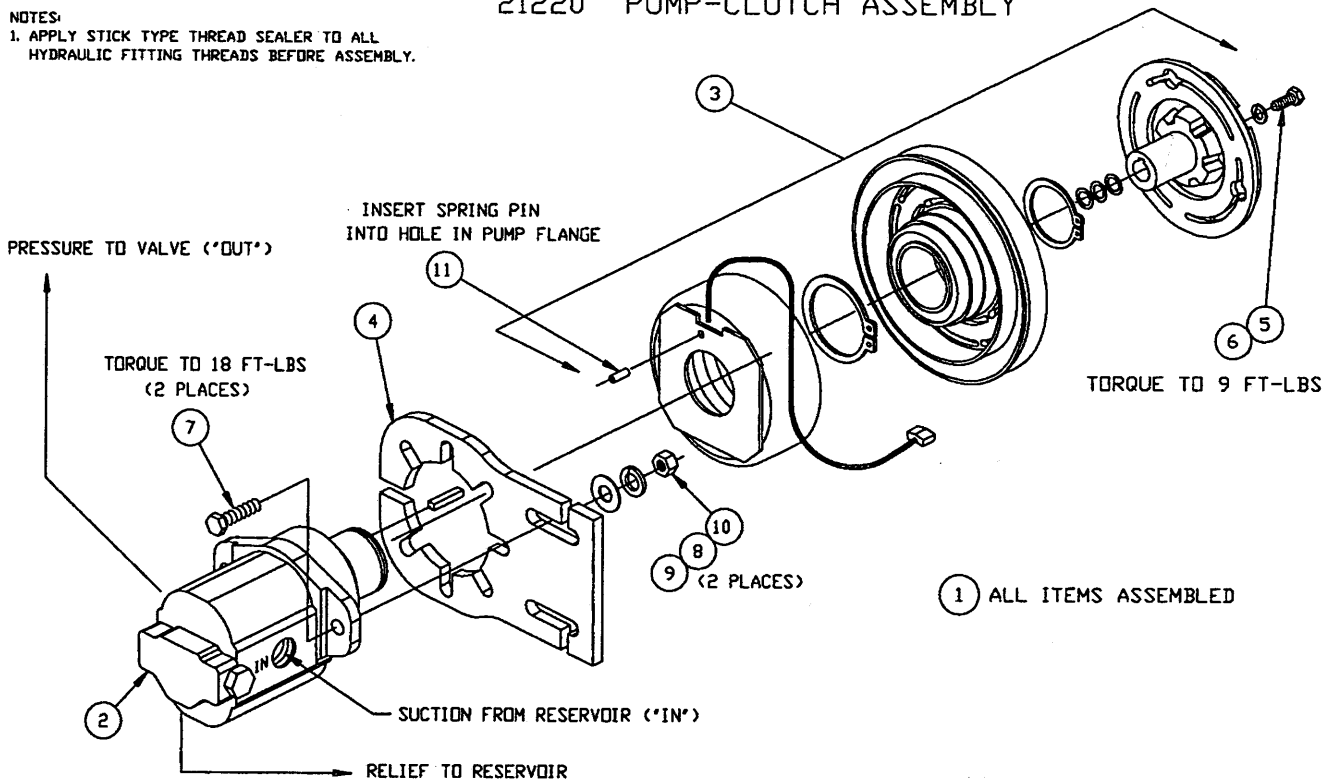

Parts List
8840-40B Electric Clutch Common Hydraulic Kit

Ref #		Qty	Part #	Description
Assy	Comp			
1		1	21220	Pump - Clutch Assembly
	2	1	21221	Pump Assy
	3	1	21222	Electric Clutch
	4	1	21219	Pump Plate
	5	1	90461	1/4 x 3/4 NC Gr 5 Cap Screw
	6	1	90359	1/4 Lock Washer
	7	2	90048	5/16 x 1-1/4 NC Gr 5 Cap Screw
	8	2	90360	5/16 Lock Washer
	9	2	90313	5/16 Plain Washer
	10	2	90332	5/16 Hex Nut (NC)
	11	1	90707	5/32 x 1/2 Spring Pin
12		1	8389	Oil Reservoir
13		1	8843	Valve Assembly - Elec. Clutch - Solenoid
	14	1	7921	Valve Manifold Assy Sol - 4000
	15	1	8851	Valve Bracket
	16	1	8852	Mounting Plate - Valve
	17	2	8849	1/8 Nptm to 1/4 Nptf Swivel Adapter
	18	1	8848	1/8 Nptm to 1/4 Nptf Reducing Adapter
	19	3	90696	1/4 x 3-1/2 (NC) Gr. 5 Cap Screw
	20	3	90359	1/4 Lock Washer
	21	3	90311	1/4 Plain Washer
	22	2	90111	3/8 x 1-1/2 (NC) Gr. 5 Cap Screw
	23	2	90361	3/8 Lock Washer
	24	2	90334	3/8 (NC) Nut
	25	1	3719	O-Ring - 013
	26	2	5827	O-Ring - 012
27		1	7714	Dash Bracket Bag (not shown)
28		1	20116	10" Lift Cylinder Assembly - XL
29		2	20117	12" Angle Cylinder Assembly - XL
30		1	8764	Filter Kit
31		1	20040	Control Harness - clutch & sol. valve
32		1	8292	Solenoid Control
33		1	21295	Bolt Bag for 8840-40B
	34	2	6814	Clevis Pin - 1 OD x 3-5/16
	35	4	6816	Anchor Pin - 1 OD x 4
	36	1	21296	Bolt Bag
	37	6	90601	1/4 x 1-1/2 Cotter Pin
	38	2	21270	3/4-16 O-ring to 3/8 NPT Swivel Elbow
	39	1	5804	1/4" Hex Male Pipe Nipple
	40	1	2318	1/4 NPT x 90° Union Elbow
	41	1	8850	Quill - 1/4 NPTF Male to 3/8 ID Hose
	42	2	8391	Quill - 3/8 NPTF Male to 1/2 ID Hose
	43	2	2780	1/4 Npt x 90 degree Street Elbow
	44	3	A1587	Hose Disconnect Assembly
	45	4	1588	Dust Plug - Closure/Male
	46	1	3042	Grommet - Rubber, Split
	47	1	4477	Grommet - Split Hose (not shown)
	48	1	8329K	Dielectric Grease Tube (not shown)
	49	1	4302	3M 560 in-line Connector
	50	1	4303	Female Connector (not shown)
	51	1	5048	Male Connector (not shown)

Parts List
7546B Electric Clutch Peculiar Hydraulic Kit

Ref #	Assy	Comp	Qty	Part #	Description
	59		1	2707	26" HP Hose, 1/4P to 3/8P
	60		2	8632	78" HP Hose, 1/4P To 1/4P
	62		1	3074	22" HP Hose, 1/4P To 1/4P
	63		3	4424	36" HP Hose, 1/4P To 1/4P
	65		1	20011	1/2" x 78" LP Hose
	66		1	2500	3/8" x 60" LP Hose
	67		1	4439	3/8" x 78" LP Hose
	68		1	1674	54" V-Belt (not shown)
	69		1	20056**	Drive Sheave
	70		1	20397	Pump Bracket
	71		1	7009	Pump Bracket Brace
	72		1	8871	Valve Plate - Sol valve
	73		1	20402	Brace - Long
	74		2	20403	Brace - Short
	75		1	20404	Brace - Reservoir
	76		1	6507	Hose Support Bracket
	77		1	20405	Bolt Bag for 7546B
		79	2	319	1/4 Npt x 90 degree Swivel Adapter Union
		80	1	4486	Bulkhead Adapter
		81	3	4485	7/8" Snap Ring - External Bowed
		82	1	8741	Bracket - Cable Boot
		83	1	8284	Cable Boot
		84	1	8688	QD/Electric Grille Plate (short)
		85	1	8686	2 QD Grille Plate (short)
		86	4	8687	Stand off Leg
		87	4	8324	Tie Wrap - 3/16 x 14 (not shown)
		88	8	3666	Tie Wrap - 3/16 x 8 (not shown)
		89	4	8127	1/4 x 45 degree Street Swivel
		90	1	8992	3" Fitting Protector
		91	3	5529	Shock Mount
		92	8	90687	1/4 x 1/2 (NC) Button Head Socket Cap Screw
		93	8	90350	1/4 (NC) Locknut
		94	1	8850	Quill - 1/4 Nptf to 3/8 ID Hose
		95	1	20057**	Bushing .75
		96	2	90124	3/8 x 2 (NC) Gr. 5 Cap Screw
		97	3	90154	3/8 x 4 (NF) Gr. 5 Cap Screw
		98	1	90103	3/8 x 1 (NC) Gr. 5 Cap Screw
		99	3	90361	3/8 Lock Washer
		100	3	90334	3/8 (NC) Nut
		101	4	90315	3/8 Plain Washer
		102	7	90042	5/16 x 1 (NC) Gr. 5 Cap Screw
		103	1	90054	5/16 x 1-1/2 (NC) Gr. 5 Cap Screw
		105	14	90360	5/16 Lock Washer
		106	14	90332	5/16 (NC) Nut
		107	4	90313	5/16 Plain Washer
		108	1	8476	1/4 NPT x 45° Street Elbow
		109	1	90202	7/16 x 5-1/4 (NF) Gr. 5 Cap Screw
		110	1	90317	7/16 Plain Washer
		113	5	4268	5/8" Spacer Washer
		114	2	90605	M8 x 1.25 x 35 Gr. 8.8 Cap Screw
		115	2	90428	M8 Lock Washer

** For Service: Order PN 20058 Drive Sheave w/Bushing

Note: The 20850 Fish-Stik™/Clutch Relay Kit is required for installations that will use the 9400 Fish-Stik™ Push Button Hand-Held Control.



1. Cylinder and Cylinder Hose Assembly

- A. Attach female half of disconnect (44) and a 1/4" NPT 45° Street Elbow (108) to 22" HP hose (62). Using bench vise to hold lift cylinder (28), remove closure from port and screw the other end of the hose directly into this port. Place lift cylinder with hose pointing towards passenger-side into ears on lift arm and upper gear. Secure with clevis pins (34) and cotter pins (37).
- B. Attach a male quick disconnect half (44) to one end of a 36" HP hose (63). Place a dust cover (45) on the end of the other 36" HP hose (63) and put another male quick disconnect half (44) on this hose.
- C. Remove closures from ports using a bench vise to hold angle cylinders (29). Screw brass forged street ells (43) into ports. Ells should point forward toward live end of cylinder and slightly upward. The driver-side cylinder uses the 36" HP hose with the dust cover and male disconnect half. The passenger-side cylinder uses the 36" HP hose with the male disconnect half and **no dust cover**. The male half will be plugged into the female half of the raise cylinder for storage. Install cylinders to their respective sides so that ells are between the cylinders and A-frame. Secure cylinders at each end with anchor pins (35) and cotter pins (37).

2. Drive Sheave Installation

Caution: Before inserting bushing, check center of crankshaft for rust or any foreign material and remove.

- A. Remove serpentine belt. Remove and discard the three cap screws holding vehicle crank pulley to vibration damper. Remove and discard cap screw and flat washer holding vibration damper to crankshaft, if vehicle is so equipped. Check vehicle crank pulley and remove any burrs around the holes that the cap screws were removed from.
- B. Install drive sheave bushing (95) into center of crank shaft, reinstall vehicle sheave. Place the drive sheave (69) center hub through the vehicle sheave and bushing. Place a 7/16 x 5-1/4 (NF) Gr. 5 cap screw (109) and flat washer (110) in center of sheave, plus three 3/8 x 4 (NF) Gr. 5 cap screws (97) with spacer washers (113) through sheave spacers. **Tighten 7/16 x 5-1/4 cap screw (torque to 50 ft-lbs) before tightening the three 3/8 cap screws (torque to 31 ft-lbs)**

NF FASTENER TORQUE (FT-LB)			
DIAMETER- THREADS PER INCH	GRADE		
			
	G2	G5	G8
1/4 - 28	6	10	14
5/16 - 24	12	19	27
3/8 - 24	23	35	50
7/16 - 20	38	55	80
1/2 - 20	55	85	120
9/16 - 18	80	120	170
5/8 - 18	110	170	240
3/4 - 16	200	300	420
7/8 - 14	180	470	670
1 - 12	270	700	980

3. Pump - Clutch Assembly and Pump Bracket

- A. Remove and save the nuts from the forward two exhaust manifold studs on the driver-side of the engine. Remove and discard bolt on back of alternator, above valve cover. Remove and discard bolt on front of alternator to left of previously remove bolt. Place both slots of pump bracket (70) onto manifold studs and attach with previously removed nuts. **Do not fully tighten any fasteners until all fasteners and pump bracket brace are installed.** Align tab with hole on pump bracket with hole on back of alternator. Install one M8 x 1.25 x 35 cap screw (114), lock washer (115) and tighten. Fasten pump bracket brace (71) to remaining hole on front of alternator with one M8 x 1.25 x 35 gr. 8.8 cap screw (114), lock washer (115), and two spacer washers (113) between brace and alternator. **Cropped out part of pump bracket brace should be positioned towards alternator cooling fins.**

Attach other end of brace to hole in pump bracket with one 5/16 x 1 1/2 (NC) gr. 5 cap screw (103), lock washer (105), and nut (106). Tighten all pump bracket fasteners and reinstall serpentine belt at this time. Using remaining hole in bent portion of pump bracket as a guide, drill a 13/32" hole through alternator bracket and fasten brackets together with a 3/8 x 1 (NC) gr. 5 cap screw (98), lock washer (99), and nut (100).

- B. The pump must be rotated in the mounting plate so that the relief port on the end plate points away from the mounting slots, as shown on page 1. Place the pump in a vise and remove the two fasteners holding the plate on the pump. Rotate the pump and reinstall the fasteners.

Install a 3/4-16 O-ring x 3/8 NPT swivel elbow (38) into both the pressure port ("OUT") and the suction port ("IN"). Using the pump's shaft as a 12:00 reference, the pressure fitting swivel will point to 2:00 and the suction fitting to 6:00. The suction port's 1/2 Quill (42) should be installed into the suction fitting at this time.

Install a 1/4 NPT hex pipe nipple (39) into the pump's relief port, tighten a 1/4 NPT x 90° union elbow (40) onto the nipple with the elbow pointing to 6:00. Tighten a 1/4 NPT x 3/8 hose quill (41) into the elbow.

DIAMETER- THREADS PER INCH	NC FASTENER TORQUE (FT-LB)		
	GRADE		
	G2	G5	G8
1/4 - 20	6	9	13
5/16 - 18	11	18	28
3/8 - 16	19	31	46
7/16 - 14	30	50	75
1/2 - 13	45	75	115
9/16 - 12	66	110	165
5/8 - 11	93	150	225
3/4 - 10	150	250	370
7/8 - 9	150	378	591
1 - 8	220	583	893

- C. Attach slotted portion of pump-clutch assembly (1) to pump bracket with two 3/8 x 2 (NC) gr. 5 cap screws (96), flat washers (101), lock washers (99), and nuts (100). Attach power steering hose support bracket (76) onto the lower pump plate mounting bolt between two 3/8 flat washers (101) and then securing it with a 3/8 lock washer (99) and 3/8 (NC) nut (100). Do not fully tighten these fasteners at this time.

CAUTION: Position the power steering hoses with at least 1" clearance from the "V" belt.

Install 54" V-belt (68) over drive and clutch sheaves. Attach the power steering hose to the support bracket with two plastic tie wraps and then position the bracket to provide at least 1" clearance from the pump V-belt. **Tighten belt and all fasteners.**

4. Solenoid Control and Harness Installation

Note: Use dielectric grease (48) to prevent corrosion on all under hood electrical connections. Fill receptacles and lightly coat ring terminals and blades before assembly.

- A. Check both sides of fire wall for wires and hot or moving engine parts. Then, on the driver side, drill a 5/8" hole in the fire wall for the control harness (31).
- B. Install the solenoid control (32) and dash bracket as per the instructions found in the Dash Bracket Bag (27) located in the common hydraulic bolt bag.
- C. Remove negative battery cable from battery. **Warning! Disconnect battery before installing, removing or replacing electrical components.**
- D. Insert control harness (31) through hole drilled in fire wall. Attach connector to plug on solenoid control. Connect the red wire from the fuse holder to a circuit which is on only when the ignition key is on. Use in-line connector (49). Route the main portion of harness (white, green, blue and black wires) to the valve. Place a grommet (46) around control harness where it passes through fire wall. Remove plastic cover from valve and install solenoid wires according to instructions inside cover. With the harness strain relief in place inside the cover, install the cover. Attach orange/black (black) wire with ring terminal exiting loom near valve to a good vehicle ground. Route portion of harness with brown/red and black/orange wires with female spade terminals to the electric clutch.

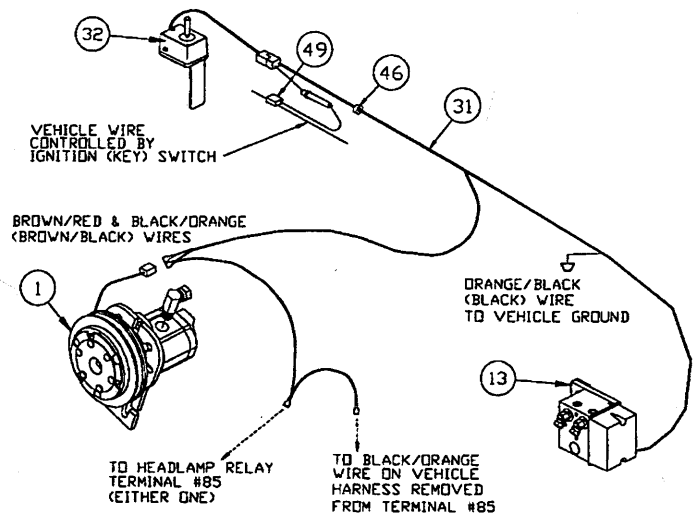

Note: Install the 20850 Fish-Stik™/Clutch Relay Kit at this time, if necessary.

Attach female spade terminals to clutch plug (brown/red to black with white stripe and black/orange to black). Fasten other black/orange wire with female spade connector to head lamp relay and male spade connector to black/orange ground wire from vehicle harness (see Diagram 1).

Note: The relay & vehicle harness are found in the peculiar light kit.

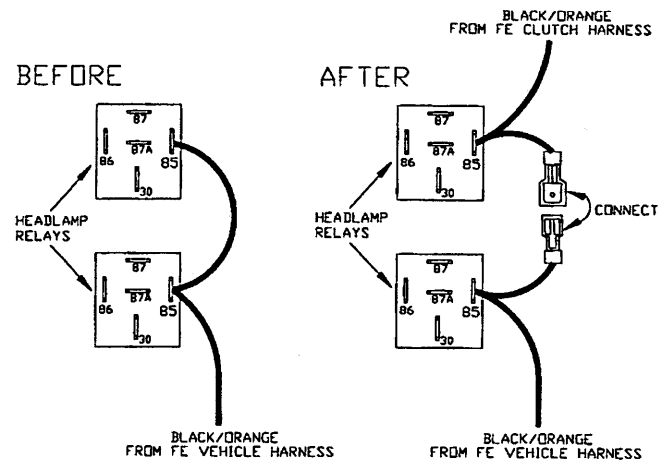

Diagram 1

- E. Install plow headlamps as per the light kit instructions. Stretch the rectangular opening of the plug cover strap (from light kit) over grille connector ends of the long battery cable (from hydraulics box) and vehicle harness (from light kit). Place the plug cover over the mold on the harness.

- F. Reconnect negative battery cable to battery terminal.

5. Valve Assembly and Valve Plate

- A. Attach valve assembly (13) to valve plate (72) with two 5/16 x 1 (NC) gr. 5 cap screws (102), lock washers (105), and nuts (106) as per the illustration. Attach valve plate braces (73), (74) to the valve plate with three 5/16 x 1 cap screws (102), lock washers (105) and nuts (106) as per the illustration. Attach shock mounts (91) onto the ends of the valve plate braces with three 5/16 lock washer (105) and nuts (106). **Do not tighten fasteners at this time.** Center the valve plate/valve assembly on the driver-side fender between the ABS/windshield washer tank and the vacuum canister so that the long valve plate brace falls on the open area of the fender behind the vacuum canister and there is no contact with the standard vehicle equipment. Using the shock mounts mark and drill three 11/32" holes in the fender. Fasten the assembly to the fender with three 5/16" (NC) flat washers (107), lock washers (105) and nuts (106). Tighten all fasteners.
- B. Install two 1/4 x 45° swivel fittings (89) into the "angle" cylinder ports on the valve according to the illustration on page 1. Make sure the swivels are pointing down slightly and forward. Install a 1/4 NPT x 3/8 I.D. hose quill (94) into the "return" port on the valve. Install a 1/4 x 45° swivel fitting (89) into the "lift" cylinder port on the valve.

6. Remote Reservoir Installation

Caution: Reservoir fill cap must be vertical to engine.

- A. Attach reservoir mounting brace (75) to left side mounting hole on reservoir (12) as viewed from the nipple end of the reservoir. The brace should run past the nipple end of the reservoir and parallel to it. Fasten the brace to the reservoir with a 5/16 x 1 Gr. 5 cap screw (102) up through the brace and reservoir, 5/16 lock washer (105) and 5/16 (NC) nut (106). Tighten the fastener.
- B. Remove the rear battery hold down bolt and save. Position the remote reservoir between the battery and the plastic intake apparatus with nipples toward the engine. Attach the reservoir mounting strap using the previously removed battery hold down bolt. With the reservoir positioned as far from the battery as possible, drill an 11/32" hole in the fender corresponding with the other reservoir mounting hole and fasten the reservoir to the fender with a 5/16 x 1 Gr. 5 cap screw (102), flat washer (107), lock washer (105) and nut (106).

7. Hydraulic Hose Installation

Caution: Keep hoses away from hot or moving engine components. Failure to do so may cause hose to burst resulting in a possible engine fire.

Note: Do not shorten LP hoses. Bends in all hoses must have sufficient radius to prevent crimping. A crimped hose may cause over-heating of the hydraulic system, hose failure, and possible engine fire.

- A. Remove grille and drill an 1-7/8" hole in the radiator core support approximately 6" below driver-side headlight and behind the parking light. Install a split hose grommet (47) around the hole.
- B. Install the 1/4 NPT end of the 26" HP hose (59) into the center swivel on the back of the valve and the 3/8 NPT end of the hose into the fitting in the "OUT" port of the pump. (The hose is long to prevent crimping on bends). Attach one end of a 78" x 3/8" LP hoses (67) to the relief quill on the pump and the other end to the top 3/8" quill on the reservoir routing the hose along the top of the radiator cowling. Attach a 1/2" quill (42) to the threaded port on the oil reservoir. Attach one end of the 78" x 1/2" LP hose (65) to the "IN" port of the pump and the other end to the 1/2" quill on the reservoir. Attach one end of the 60" x 3/8" LP hose (66) to the quill on the back of the valve and the other end to the remaining quill on the reservoir. Secure the fitting protector (90) to the top pump fitting with a tie wrap (88). Cut return LP hose approximately 5" from the quill on the valve and install the in line oil filter as per filter kit instructions (30) located in the common hydraulic kit. Secure LP hoses where possible with plastic tie wraps (87).
- C. Attach one end of a 36" HP hose (63) to the 1/4 x 45° swivel fitting installed in the driver-side angle port of valve. Route this hose out through the radiator core support and out through grille low and about 14" from center on driver-side. Attach female half of quick disconnect (44) to the QD/Electric grille plate (84) with a snap ring (81). Put a dust plug (45) on the end of a 45° swivel fitting (89) and attach it to quick disconnect. Attach HP hose to 45° swivel. Route the headlamp connector (with dust cover) from previously installed light kit vehicle harness, through radiator core support. Slide connector into the slot provided in the QD/Electric grille plate. The grille plate should be oriented with head lamp connector to the inside of vehicle. Attach grille plate to grille with two long tie wraps (87).
- D. Attach one end of a 78" HP hose (60) to the 1/4 x 45° swivel installed in the passenger-side angle port on valve and one end of the other 78" HP hose (60) to the 1/4 x 45° swivel on the lift port of the valve. Route both these hoses down through the radiator core support, across the front of the radiator, out through the radiator core support and out through grille low and about 14" from center on passenger-side. Attach female half of quick disconnect (44) to one hole of the 2-QD grille plate (85) with a snap ring (81). Install 1/4 x 90° swivel (79) with a dust plug (45) to back of disconnect. Attach the bulk head adapter (80) with a snap ring (81) to the other hole in the 2-QD grille plate. Install a male end of quick disconnect (44) to the bulk head adapter. Attach a 1/4 x 90 degree swivel (79) with dust plug (45) to the other end of disconnect. Attach the 78" HP angle hose to the female disconnect and the 78" lift hose to the male disconnect. Place the "angle" female disconnect on grille plate towards the outside of vehicle and attach grille plate to grille with two long tie wraps (87).

Note: Some GMC models with fine mesh grilles may have to use stand off legs (86) fastened with four 1/4 x 1/2 socket head cap screws (92) and locknuts (93) on each grille plate.

- E. Trucks using stand off legs will attach grille plates as described in step "D" above except the two 90° (79) and one 45° (89) swivel fittings will not be used.
- F. Install cable boot bracket (82) on driver-side headgear brace, between brace and fasteners. Insert cable boot (83) on over bracket.

8. OPERATIONS

- A. Check all fittings and fasteners for tightness. Secure hoses with nylon tie wraps (88).
- B. Attach hose disconnects, push lift arm all the way down, and fill reservoir with FISHER® High Performance Hydraulic Fluid (recommended for superior cold-weather performance) or type "A" automatic transmission fluid. Start engine, lift and angle blade several times. **If blade angles opposite from control lever position, reverse the two angle hoses at the valve. Raise front end of vehicle until plow is clear of ground with lift cylinder fully retracted. Check reservoir oil level. Angle blade (with lift cylinder retracted) to remove air from system. Recheck reservoir oil level.**

NOTE: The installer must inform the End User of the proper procedure for removing and residual hydraulic pressure that may be trapped in the raise or angle hoses. The plow will be much easier to install or remove if the proper procedures are followed.

Before coupling or uncoupling the hydraulic disconnects you must turn off the engine and then turn the key to the "on" position. (The red LED light will be lit.) Move the control to the four plowing positions. Activate lower/float before removing or installing the plow.