

26640

ISOLATION MODULE ELECTRICAL SYSTEM

Installation Instructions

Ford/International

⚠ CAUTION

Read this document before installing the snowplow.

⚠ CAUTION

See your sales outlet for application recommendations. The Kit Selection Guide/ Selection List has specific vehicle and snowplow requirements.

SAFETY DEFINITIONS

⚠ WARNING

Indicates a potentially hazardous situation that, if not avoided, could result in death or serious personal injury.

⚠ CAUTION

Indicates a situation that, if not avoided, could result in damage to product or property.

NOTE: Identifies tips, helpful hints, and maintenance information the owner/operator should know.

BATTERY SAFETY

⚠ CAUTION

Batteries normally produce explosive gases which can cause personal injury. Therefore, do not allow flames, sparks or lit tobacco to come near the battery. When charging or working near a battery, always cover your face and protect your eyes, and also provide ventilation.



Batteries contain sulfuric acid which burns skin, eyes and clothing.

Disconnect the battery before removing or replacing any electrical components.

TORQUE CHART

⚠ CAUTION

Read instructions before assembling. Fasteners should be finger tight until instructed to tighten according to the torque chart. Use standard methods and practices when attaching snowplow, including wearing proper personal protective safety equipment.

Recommended Fastener Torque Chart (Ft.-Lb.)			
Size	 SAE Grade 2	 SAE Grade 5	 SAE Grade 8
1/4-20	6	9	13
5/16-18	11	18	28
3/8-16	19	31	46
3/8-24	24	46	68
7/16-14	30	50	75
1/2-13	45	75	115
9/16-12	66	110	165
5/8-11	93	150	225
3/4-10	150	250	370
7/8-9	150	378	591
1-8	220	583	893
Metric Grade 8.8 (Ft.-Lb.)			
Size	Torque	Size	Torque
M 6	7	M 12	60
M 8	17	M 14	95
M 10	35	M 16	155
These torque values apply to fasteners except those noted in the instruction.			

FUSES

The vehicle control harness contains two automotive-style fuses. One fuse is for the snowplow park/turn lamp power and the other is for the snowplow control power. If a problem should occur and fuse replacement is necessary, the replacement fuse should be of the same value as the original. Installing a fuse of a larger value could damage the system.

MOTOR RELAY AND VEHICLE CABLE ASSEMBLY INSTALLATION

⚠ CAUTION

Batteries normally produce explosive gases which can cause personal injury. Therefore, do not allow flames, sparks or lit tobacco to come near the battery. When charging or working near a battery, always cover your face and protect your eyes, and also provide ventilation.

Batteries contain sulfuric acid which burns skin, eyes and clothing.

Disconnect the battery before removing or replacing any electrical components.

1. Turn off the vehicle ignition.
2. Disconnect both the NEGATIVE (–) and the POSITIVE (+) battery cables.
3. Route the vehicle cable assembly, from the grille or bumper, along the vehicle frame toward the battery. Be sure to avoid sharp edges and hot or moving parts. For now, cable tie only the end section closest to the grille.

NOTE: This vehicle is equipped with a tilt hood, so a service loop will be necessary when making the transition from the tilt hood to the frame. Check the cable installation for interference by raising and lowering the hood a number of times. Add anti-chafing material (installer-supplied) as needed.

4. Choose a location on the vehicle frame to mount the motor relay mounting bracket where it will be protected from road splash and debris kicked up by the front tires and where it will be within 85" of the vehicle battery. Position the motor relay near the end of the vehicle cable assembly.

NOTE: Motor relay terminals must be up or horizontal.

⚠ CAUTION

Before installing self-drilling screws or drilling mounting holes, check the selected mounting area for any wires, hoses, or other obstructions.

5. Attach the mounting bracket to the frame using existing holes when possible. If no holes exist, use the mounting bracket as a template and mark and drill two, 13/32" mounting holes in the frame. Attach the mounting bracket to the frame using the 3/8" x 1-1/4" cap screws, washers, and locknuts provided.
6. Mount the motor relay to the mounting bracket with the 1/4" hardware provided.
7. Attach the red wire from the vehicle cable assembly to one of the large terminals on the motor relay. Secure with a lock washer and 5/16" nut.

NOTE: Use dielectric grease on all electrical connections to prevent corrosion. Fill receptacles and lightly coat ring terminals and blades before assembly.

8. Connect the black wire from the vehicle cable assembly to a ground bolt on the vehicle frame or the engine. When using the frame as a ground, clean away any paint or dirt to ensure a good ground connection. The black/orange wire from the vehicle cable assembly will connect to the mating connector on the vehicle control harness.

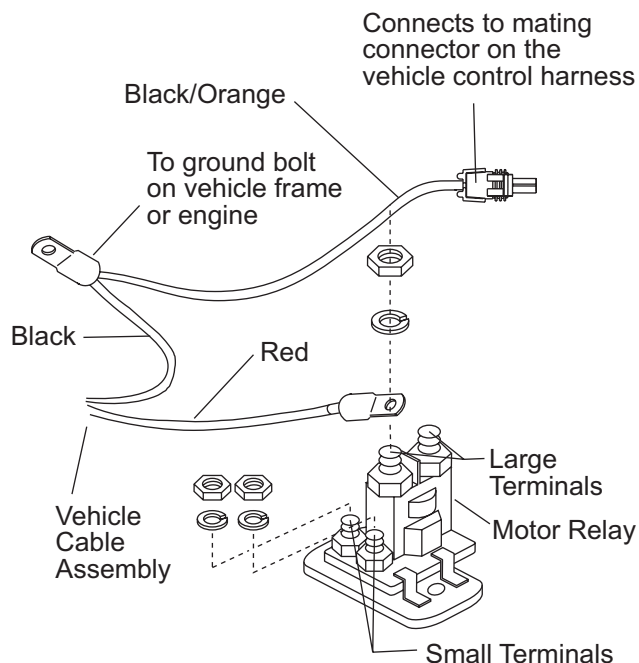

PLUG COVER INSTALLATION

1. Stretch the rectangular opening of the plug cover strap over the harness plug of the vehicle cable assembly. Place the plug cover over the molded harness plug when snowplow is not in use.

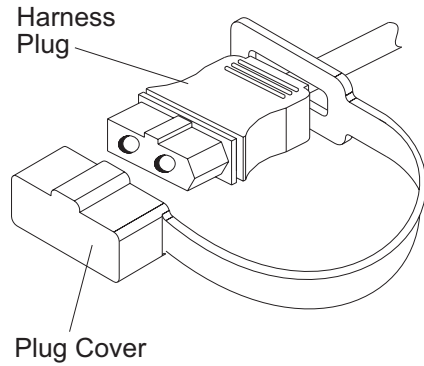

2. If grille plates are used, choose the one most suitable for your installation. Slide the harness plug into the plate.

NOTE: When choosing a location for the grille plate, keep in mind the connection between the vehicle and the snowplow. Mounting the grille plate too close to the center of the vehicle may make it difficult to make your electrical connections to the snowplow.

3. Mount grille plate to the vehicle grille using the supplied cable ties.
4. If you choose not to install a grille plate, secure the cable assembly so it is protected when not in use and is easily retrieved for connection to the snowplow.

ISOLATION MODULE MOUNTING

The design of the Isolation Module allows it to be mounted to a variety of surfaces **within** the engine compartment. The function of the Isolation Module will not be affected by its mounting orientation.

⚠ CAUTION

Before installing self-drilling screws or drilling mounting holes, check the selected mounting area for any wires, hoses, or other obstructions.

Locate a flat surface within the engine compartment of the vehicle for mounting the Isolation Module. For example, the fire wall, side of washer reservoir, fender well or radiator shroud are possible mounting locations. If a flat surface cannot be located, cable tie the Isolation Module to existing brackets or harnessing. Reclosable fastener strips, cable ties, and self-drilling screws are supplied for mounting the Isolation Module. When using the reclosable fastener strips, the mounting surface must be free of dirt and grease. If using self-drilling screws, install the screws in opposite corners if possible.

Suggested Mounting Options:

- Flat, non-metallic, non-drillable surfaces – use reclosable fasteners
- Flat, non-metallic, drillable surfaces – use self-drilling screws (supplied), nuts, and cap screws (not supplied)
- Flat metallic surfaces – use reclosable fasteners, self-drilling screws (supplied), nuts, and cap screws (not supplied)
- No flat surface found – use cable ties and tie to existing brackets or harness

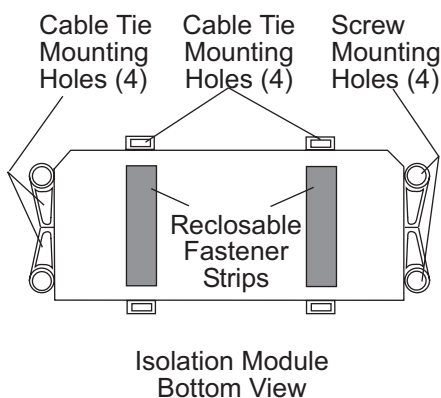

VEHICLE LIGHTING AND VEHICLE CONTROL HARNESS INSTALLATION

Vehicle lighting and vehicle control harnesses are designed to plug into one another when the snowplow is not attached. The control harness exits the grille or bumper on the passenger side and the lighting harness exits on the driver side. Plug the harnesses together before cable tying them to ensure adequate length.

1. Find a location in the grille or bumper on the driver side for routing the vehicle lighting harness. Then find a location in the grille or bumper on the passenger side for the vehicle control harness.

NOTE: This vehicle is equipped with a tilt hood, so a service loop will be necessary when making the transition from the tilt hood to the frame. Check the cable installation for interference by raising and lowering the hood a number of times. Add anti-chafing material (installer-supplied) as needed.

2. Route both harnesses around or through the radiator bulkhead and along the vehicle frame to the Isolation Module. Do not cable tie the harnesses to the frame at this time.
3. Make the following connections:
 - Vehicle control harness to Position 1 on Isolation Module
 - Vehicle lighting harness to Position 2 on Isolation Module.
 - Single-wire connector (black/orange wire) from vehicle control harness to single-wire connector (black/orange wire) on vehicle lighting harness.
 - Configuration plug onto vehicle control harness 3-position plug near Isolation Module. (Refer to plug configuration drawing for instructions.)

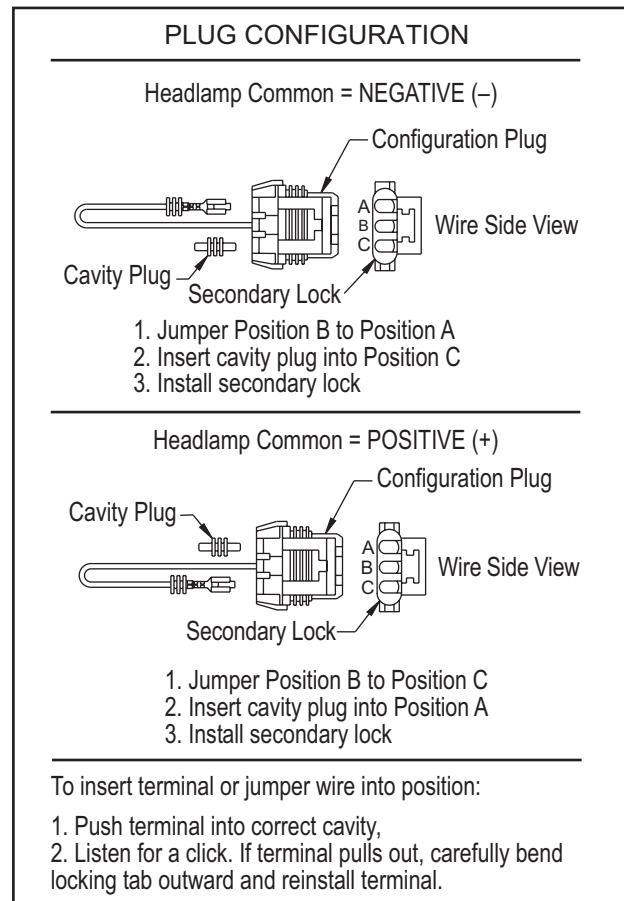

NOTE: If unsure of headlamp common, configure plug for a NEGATIVE (-) common. Complete the installation and check headlamp functions. Turn on the vehicle lights in the low beam mode. Both low beams should be on. If the left low beam does not illuminate, change plug configuration to POSITIVE (+) common and test headlamp functions.

- Route the end of the vehicle control harness with the white, 6-pin connector or the 10 loose terminals to the fire wall. Route the vehicle control harness breakout with four wires to the motor relay.

Motor relay small terminal connections:

Straight blades: brown/red and black/orange
V-plows: brown/red and brown/green

Secure wires to small terminals of motor relay with #10 lock washers and 10-32 nuts.

- Connect the single-wire connector (black/orange wire) from the vehicle control harness breakout to the single-wire connector (black/orange wire) from the vehicle cable assembly. Do not cable tie the harness at this time.
- Attach the 90" red battery cable and the red/green wire from the vehicle control harness to a large terminal on the motor relay with a lock washer and 5/16" nut. Route the 90" red battery cable between motor relay terminal and POSITIVE (+) battery terminal, avoiding sharp edges and hot or moving parts. Do not make battery connection at this time.

NOTE: The supplied 90" battery cable may be too long on certain vehicles. Coil and cable tie extra length in the battery box or shorten cable as needed.

⚠ CAUTION

Before installing self-drilling screws or drilling mounting holes, check the selected mounting area for any wires, hoses, or other obstructions.

- Drill a 5/8" hole through the fire wall of the vehicle in a convenient location away from sharp edges, and hot or moving parts. If access through the fire wall already exists, use proper chafing material or existing plug cover.

- Straight blade controls only:** Push the braided harness breakout with the cab control connector through the fire wall hole into the cab. Use a grommet to protect the harness where it passes through the fire wall. Route the harness to the selected control mounting location. To mount the control, follow the instructions supplied with the control.
- V-plow control only:** Remove the packing material from the end of the vehicle control harness. This exposes 10 socket-type terminals. Carefully push these terminals through fire wall hole into the cab. Use a grommet to protect the harness where it passes through the fire wall. Route the harness to the selected control mounting location. Follow the instructions in the next section to attach the terminals to the connector. To mount the control, follow the instructions supplied with the control.
- Locate an accessory wire controlled by the ignition switch. Acceptable accessory wires show +12V when the ignition switch is on, and 0V when it is off.
- Route the red wire from the vehicle control harness to this location and trim away excess length.
- Following the recommended splicing procedure (see page 12), splice the red wire into the switched accessory wire using the supplied parallel splices and heatshrink tubing.

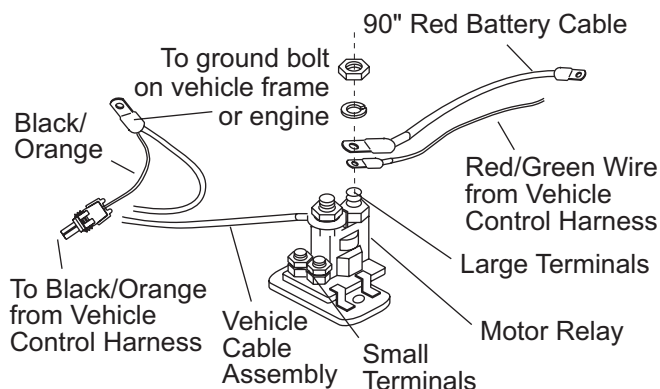

UNDER-DASH VEHICLE CONTROL HARNESS CONNECTOR PIN ASSIGNMENTS

V-Plow Control Only

1. In the cab, pass the 10 socket-type terminals through the vehicle harness bracket.
2. Insert each of the 10 socket-type terminals into the connector housing. Refer to chart below.
3. Attach the vehicle harness bracket to the vehicle with the supplied #8-18 x 5/8" tapping screws. Secure the connector housing to the vehicle harness bracket with the #6 x 1/4" tapping screws and lock washers.

NOTE: You will feel a snap as the terminals are successfully inserted. An extraction tool is provided for removing pin terminals if necessary. Keep this tool for future use.

NOTE: Cable tie control harness and accessory tap away from any moving parts, brake, clutch, gas or parking brake pedals.

Wire Color	Pin No.
Light Blue w/ Orange Stripe	1
Blue w/ Orange Stripe	2
Black w/ White Stripe	3
Light Green	4
Light Blue	5
White w/ Yellow Stripe	6
Brown w/ Red Stripe	7
Red	8
Black w/ Orange Stripe	9
Brown w/ Green Stripe	10

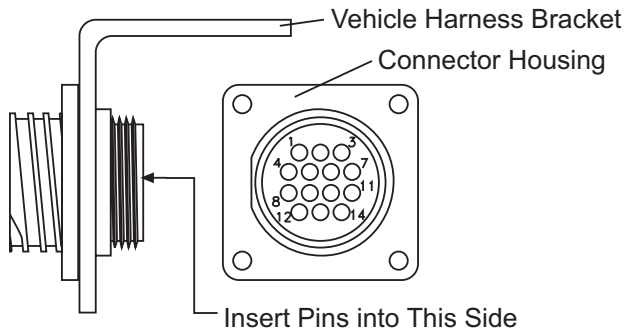

FORD - PLUG-IN HARNESS INSTALLATION

NOTE: The long plug-in harness will be used on the same side of the vehicle as the Isolation Module. The short plug-in harness with the extension harness will be used on the opposite side. Example: The Isolation Module is mounted on the passenger side of the vehicle. The long plug-in harness will be installed on the passenger side. The short plug-in harness and the extension harness will be installed on the driver side.

NOTE: Instructions are written assuming the Isolation Module is located on the passenger-side of the vehicle, in the back near the fire wall.

1. Remove the driver-side outer headlamp molding, the park/turn lamp assembly, the sealed beam retainer, and the sealed beam. Move the vehicle headlamp wiring and connector to one side before going to the next step.
2. Drill a 1" hole in the back of the headlamp housing using the 1/8" existing hole as a guide. Route the end of the plug-in harness with a male and female connector into the driver-side headlamp housing.

NOTE: Use dielectric grease on all electrical connections to prevent corrosion. Fill receptacles and lightly coat ring terminals and blades before assembly.

3. Connect the plug-in harness male connector to the vehicle harness female connector removed from the sealed beam. Connect the plug-in harness female connector to the sealed beam. Reinstall the sealed beam and the sealed beam retainer. Install a rubber grommet around the plug-in harness and insert it into the drilled hole in the headlamp housing.

NOTE: Only the short plug-in harness connects to the vehicle parking light circuit.

4. Route the purple and brown wires from the plug-in harness under the existing park/turn grommet. Identify the POSITIVE (+) driver-side turn signal wire. Splice the purple wire from the plug-in harness into this wire following the recommended splicing procedure (see page 12). Locate the POSITIVE (+) parking light wire. Splice the brown wire from the plug-in harness into this wire following the splicing procedure. Reinstall the park/turn lamp assembly and the outer headlamp molding.
5. Route the plug-in harness along the existing vehicle wiring toward the passenger-side headlamp housing. Cable tie as needed.
6. Plug the extension harness into the short plug-in harness and continue routing harness to the passenger side of the vehicle.
7. Continue routing the extension harness along the frame to the Isolation Module. Connect to Position 3 of the Isolation Module. Do not cable tie at this time.
8. Remove the passenger-side outer headlamp molding, the park/turn lamp assembly, the sealed beam retainer, and the sealed beam. Move the vehicle headlamp wiring and connector to one side before going to the next step.
9. Drill a 1" hole in the back of the headlamp housing using the existing 1/8" hole as a guide. Route the end of the plug-in harness with the female connector into the passenger-side headlamp housing.

NOTE: Use dielectric grease on all electrical connections to prevent corrosion. Fill receptacles and lightly coat ring terminals and blades before assembly.

10. Connect the plug-in harness male connector to the vehicle harness female connector removed from the sealed beam. Connect the plug-in harness female connector to the sealed beam. Reinstall the sealed beam and the sealed beam retainer. Install a rubber grommet around the plug-in harness and insert it into the drilled hole in the headlamp housing.
11. Route the purple wire from the plug-in harness under the existing park/turn grommet. Identify the passenger side turn signal wire. Splice the purple wire from the plug-in harness into this wire following the recommended splicing procedure (see page 12). Reinstall the park/turn lamp assembly and the outer headlamp molding.
12. Route the plug-in harness from the headlamp assembly along existing vehicle wiring to the frame. Cable tie as needed. Continue routing the harness along the frame to the Isolation Module and connect to Position 4. Do not cable tie harness along the frame at this time.
13. Connect the 90" battery cable and the vehicle battery cable to the POSITIVE (+) terminal of the battery. Connect the vehicle ground cable to the NEGATIVE (-) battery terminal. Cable tie harnesses to existing cables or brackets, away from any hot, sharp, or moving parts.

NOTE: This vehicle is equipped with a tilt hood, so a service loop will be necessary when making the transition from the tilt hood to the frame. Check the cable installation for interference by raising and lowering the hood a number of times. Add anti-chafing material (installer-supplied) as needed.

INTERNATIONAL - PLUG-IN HARNESS INSTALLATION

NOTE: The extension harness is provided for those applications where the Isolation Module is mounted some distance away from the furthest headlamp. In applications where extra harness length may be necessary, the combination of the extension harness and the short plug-in harness should provide the extra length required.

NOTE: Instructions assume the Isolation Module is located on the passenger side of the vehicle, back near the fire wall.

For vehicles using HB-5 type headlamps: See page 15 of these instructions to configure the long and short plug-in harnesses.

1. Remove the driver-side outer headlamp molding, bulb retainer, and bulb. Route the end of the plug-in harness into the headlamp housing.

NOTE: It may be necessary to loosen or remove the headlamp bulb alignment bracket.

2. Connect the plug-in harness male connector to the vehicle harness female connector removed from the sealed beam. Connect the plug-in harness female connector to the sealed beam.
3. Identify the driver-side turn signal wire. Splice the purple wire from the plug-in harness into this wire following the recommended splicing procedure (see page 12). Locate the parking light wire. Splice the brown wire from the plug-in harness into this wire following the splicing procedure.
4. Reinstall the bulb, bulb retainer, and the outer headlamp molding.
5. Route the plug-in harness along the existing vehicle wiring toward the passenger-side headlamp housing. Use cable ties to attach the harness to the existing vehicle wiring as needed.

6. Plug the extension harness into the short plug-in harness and continue routing harness to the passenger side of the vehicle.
7. Continue routing the extension harness along the frame to the Isolation Module. Connect to Position 3 of the Isolation Module. Do not cable tie at this time.
8. Remove the passenger-side outer headlamp molding, bulb retainer, and bulb. Route the plug-in harness male and female connectors into the headlamp housing.
9. Connect the plug-in harness male connector to the vehicle harness female connector removed from the headlamp bulb. Connect the plug-in harness female connector to the headlamp bulb. Reinstall the bulb, bulb retainer, and the outer headlamp molding.
10. Identify the passenger-side turn signal wire. Splice the purple wire from the plug-in harness into this wire following the recommended splicing procedure (see page 12).
11. Route the plug-in harness from the headlamp assembly along existing vehicle wiring to the frame. Cable tie as needed. Continue routing the harness along the frame to the Isolation Module and connect to Position 4. Do not cable tie harness along the frame at this time.
12. Connect the 90" battery cable and the vehicle battery cable to the POSITIVE (+) terminal of the battery. Connect the vehicle ground cable to the NEGATIVE (-) battery terminal. Cable tie harnesses to existing cables or brackets, away from any hot, sharp, or moving parts.

NOTE: This vehicle is equipped with a tilt hood, so a service loop will be necessary when making the transition from the tilt hood to the frame. Check the cable installation for interference by raising and lowering the hood a number of times. Add anti-chafing material (installer-supplied) as needed.

RECOMMENDED SPLICING PROCEDURE

1. Locate wire to be spliced into.
 2. Cut wire at least 1-1/2" from any other splice, connector, or terminal. If wires are covered by tubing or braid, remove enough of it to achieve the minimum clearance required.
 3. Strip away 3/8" of the insulation from the ends of the wires to be spliced.
 4. Slide two wires into one end of the supplied parallel splice.
 5. Place a piece of heatshrink tubing (3/16" x 1-1/4" long) over the remaining wire to be spliced.
 6. Insert wire into the open end of the splice and crimp using an appropriate crimp tool. One or two crimps may be necessary to ensure a good connection. No wire strands should be visible outside of the splice.
 7. Preheat a soldering tool for at least one minute to help promote even solder flow.
 8. Apply heat to the splice. Avoid heating too close to the insulation. Apply solder to the wires. Use just enough solder to produce an even flow through the splice. **Use rosin core solder ONLY. Do not use acid core solder.**
-
- NOTE: Avoid using an excessive amount of solder as it can result in wicking. Wicking occurs when solder travels up the wire core. This may cause the wire to become stiff or brittle which could lead to a broken or open circuit.**
-
9. Check circuits for continuity.
 10. Cover the splice with heatshrink tubing. The tubing should extend beyond the splice on both sides.
 11. Using a hot air source, starting in the center and working to either side, apply heat until the tubing recovers and glue can be seen around the edges. Allow the tubing to cool before handling.

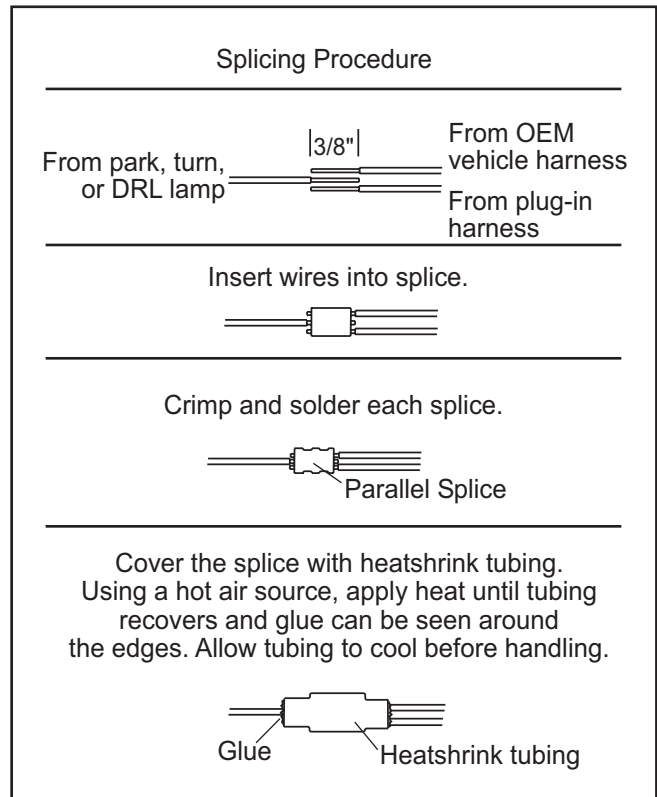

NOTE: The splices supplied will accommodate 18-gauge wires as shown. For larger gauge wires, cut the wire, strip the ends 3/8" to 1/2", and twist together. Apply solder to the splice and cover with heatshrink tubing.

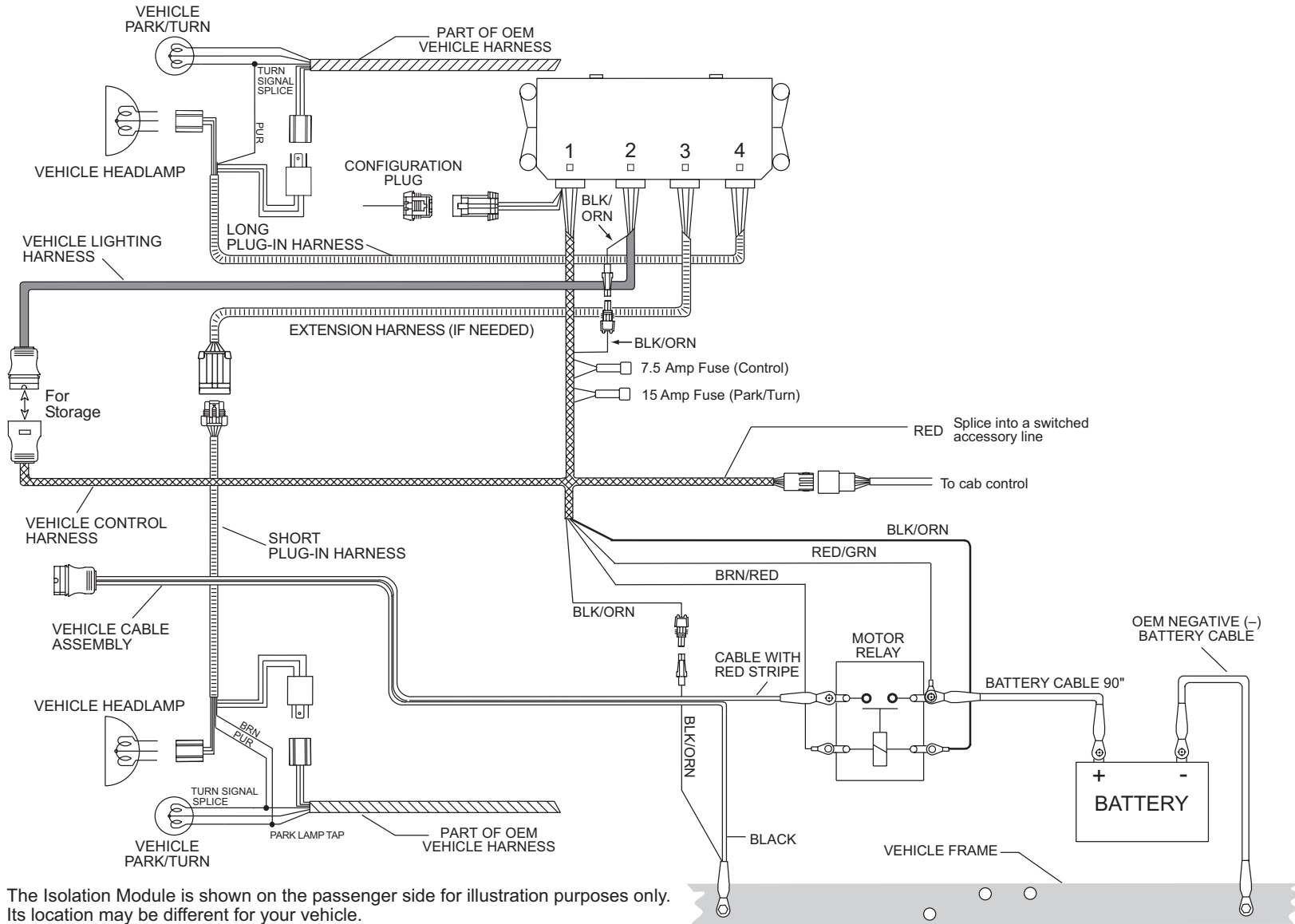

The Isolation Module is shown on the passenger side for illustration purposes only. Its location may be different for your vehicle. The short plug-in harness contains the park lamp wire.

SYSTEM DIAGRAM – STRAIGHT BLADES

SYSTEM DIAGRAM - V-PLOWS

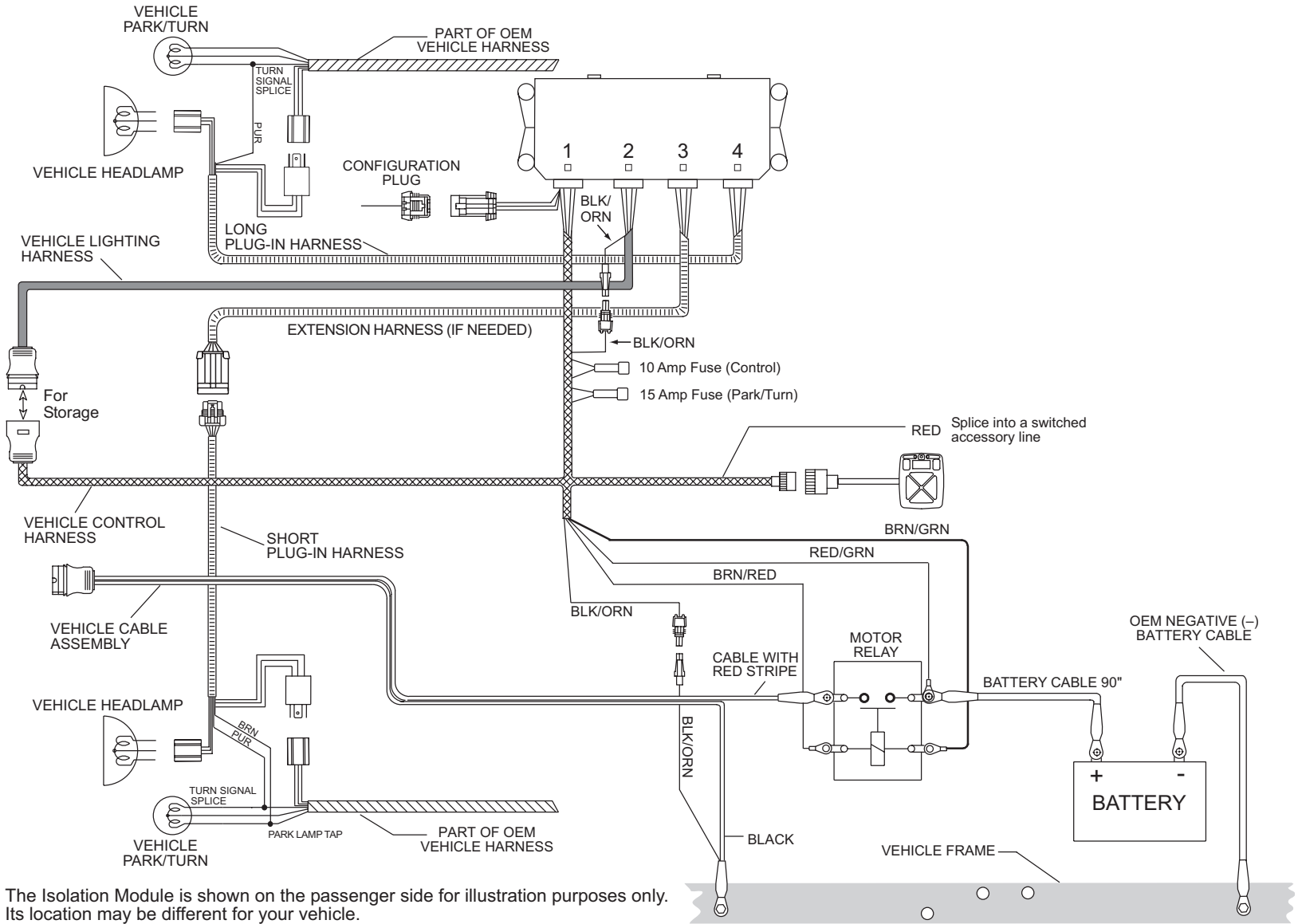

The Isolation Module is shown on the passenger side for illustration purposes only. Its location may be different for your vehicle. The short plug-in harness contains the park lamp wire.

HEADLAMP WIRING FOR VEHICLES WITH HB-5 HEADLAMPS

Plug Configuration

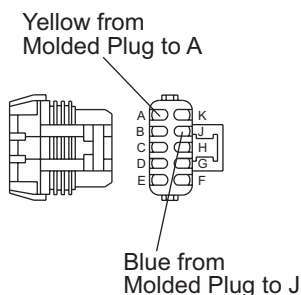
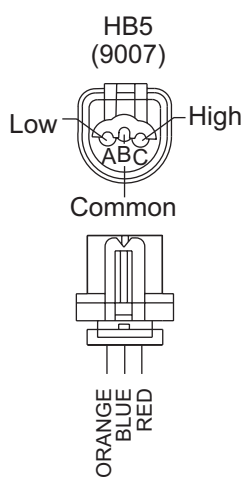

10-PIN CONNECTOR:
 BLUE – POSITION J
 YELLOW – POSITION A

Headlamp Wiring (9007)

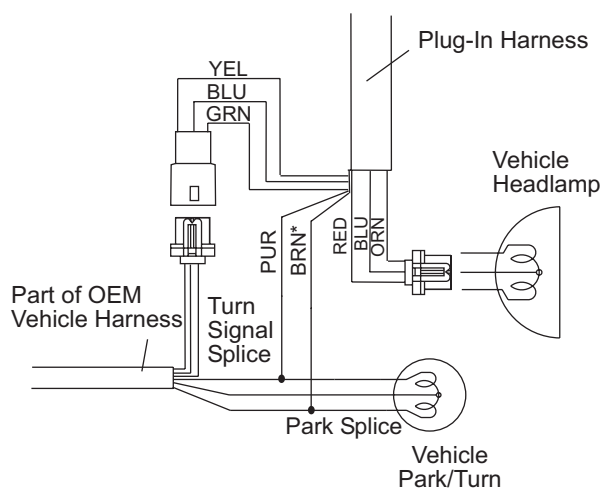

Install wires in both connectors as shown.
 Install supplied secondary connector locks.

* Short plug-in harness only

HEADLAMP WIRING FOR VEHICLES WITH 2B, 2D, or HB2 HEADLAMPS

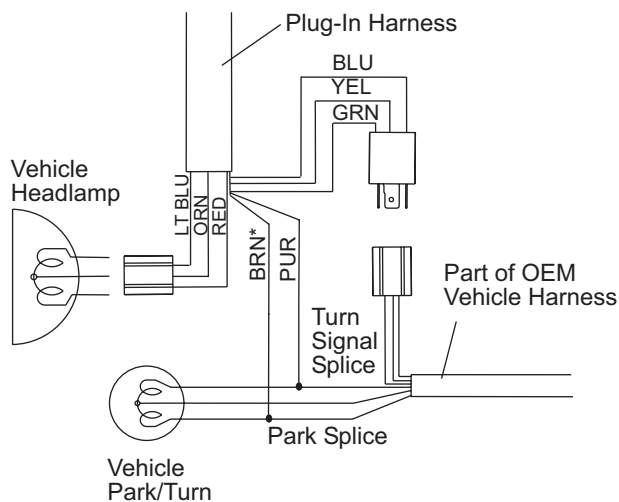

* Short plug-in harness only

The company reserves the right under its product improvement policy to change construction or design details and furnish equipment when so altered without reference to illustrations or specifications used herein.

Printed in USA
