



Fisher Engineering

P.O. Box 529 Rockland, Maine 04841 • www.fisherplows.com

28888 V

August 1, 2006
Lit. No. 27589, Rev. 11



COMMON ATTACHMENT KIT

V Series

Installation Instructions

⚠ CAUTION

Read this document before installing the snowplow.

⚠ CAUTION

See your FISHER® outlet for specific vehicle application recommendations before installation. The Kit Selection Guide has specific vehicle and snowplow requirements.

SAFETY DEFINITIONS

⚠ WARNING

Indicates a potentially hazardous situation that, if not avoided, could result in death or serious personal injury.

⚠ CAUTION

Indicates a potentially hazardous situation that, if not avoided, may result in minor or moderate injury. It may also be used to alert against unsafe practices.

NOTE: Indicates a situation or action that can lead to damage to your snowplow and vehicle or other property. Other useful information can also be described.

WARNING/CAUTION AND INSTRUCTION LABELS

Become familiar with and inform users about the warning labels on the back of the blade, and the instruction label on the headgear.

NOTE: If labels are missing or cannot be read, see your sales outlet.

Warning/ Caution Label

⚠ WARNING

LOWER BLADE WHEN VEHICLE IS PARKED.

REMOVE BLADE ASSEMBLY BEFORE PLACING VEHICLE ON HOIST.

DO NOT EXCEED GVWR OR GAWR INCLUDING BLADE AND BALLAST.

⚠ CAUTION

READ OWNER'S MANUAL BEFORE OPERATING OR SERVICING SNOWPLOW.

TRANSPORT SPEED SHOULD NOT EXCEED 45 MPH. REDUCE SPEED UNDER ADVERSE TRAVEL CONDITIONS.

PLOWING SPEED SHOULD NOT EXCEED 10 MPH.

SEE YOUR SALES OUTLET FOR APPLICATION RECOMMENDATIONS.

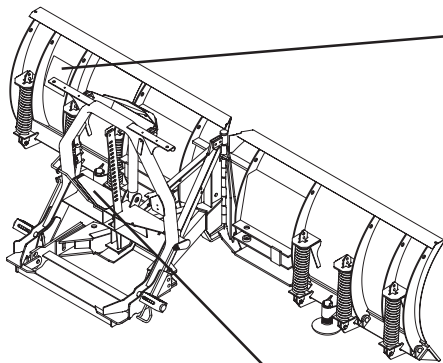

U.S. Patents 4,280,062; 4,999,935; 5,353,530; 5,420,480; RE 35,700; 6,253,470; CAN Patent 2,060,425; and other patents pending.

Instruction Label

1. Push **Pin Release Handle** down to pull out **Connecting Pins**.
2. Drive vehicle slowly to engage **Pushplates** into **Attachment Arms**.
3. Stand in front of blade. Fully raise **Pin Release Handle** to release **Connecting Pins**.
4. Push **Headgear** toward vehicle to allow **Connecting Pins** to fully engage **Pushplates**. If unable to push **Headgear** from in front of blade, stand in front of **Headgear** on driver side and push **Headlamp Bracket**.
5. Pull out **Jack Lock**. Push **Pin Release Handle** into **Stop**.
6. While holding **Jack Lock** out, use **Jack Handle** to raise **Jack** fully. Release **Jack Lock**.
7. Attach all electrical connectors.

1. Place control in Lower/Float to put blade down.
2. Pull and hold **Jack Lock** out. **Jack** will drop to ground. Then pull **Pin Release Handle** away from **Stop** and **Jack Lock**. Release **Jack Lock**. Verify **Jack** is locked by trying to lift **Jack**.

3. Stand in front of blade. While pushing **Headgear** toward vehicle with left hand, push **Pin Release Handle** down to disengage **Connecting Pins**. Make sure **Connecting Pins** are fully retracted. If unable to push **Headgear** from in front of blade, stand in front of **Headgear** on driver side and push **Headlamp Bracket**.
4. Detach all electrical connectors.

Read Owner's Manual For Complete Instructions

27451

SAFETY PRECAUTIONS

Improper installation and operation could cause personal injury, and/or equipment and property damage. Read and understand labels and the *Owner's Manual* before installing, operating or making adjustments.

⚠ WARNING

Lower blade when vehicle is parked. Temperature changes could change hydraulic pressure, causing the blade to drop unexpectedly or damaging hydraulic components. Failure to do this could result in serious personal injury.

⚠ WARNING

The driver shall keep bystanders clear of the blade when it is being raised, lowered or angled. Do not stand between the vehicle and the blade or within 8 feet of a moving blade. A moving or falling blade could cause personal injury.

⚠ WARNING

Keep hands and feet clear of the blade and A-frame when mounting or removing the snowplow. Moving or falling assemblies could cause personal injury.

⚠ WARNING

Do not exceed GVWR or GAWR including the blade and ballast. The rating label is found on the driver-side vehicle door cornerpost.

⚠ WARNING

Remove blade assembly before placing vehicle on hoist.

⚠ CAUTION

Refer to the Kit Selection Guide for minimum vehicle recommendations and ballast requirements.

⚠ CAUTION

To prevent accidental movement of the blade, always turn the ON/OFF switch to OFF whenever the snowplow is not in use. The control indicator light will turn off.

PERSONAL SAFETY

- Remove ignition key and put the vehicle in park or in gear to prevent others from starting the vehicle during installation or service.
- Wear only snug-fitting clothing while working on your vehicle or snowplow.
- Do not wear jewelry or a necktie, and secure long hair.
- Wear safety goggles to protect your eyes from battery acid, gasoline, dirt and dust.
- Avoid touching hot surfaces such as the engine, radiator, hoses and exhaust pipes.
- Always have a fire extinguisher rated BC handy, for flammable liquids and electrical fires.

HYDRAULIC SAFETY

⚠ WARNING

Hydraulic fluid under pressure can cause skin injection injury. If you are injured by hydraulic fluid, get medical attention immediately.

- Always inspect hydraulic components and hoses before using. Replace any damaged or worn parts immediately.
- If you suspect a hose leak, DO NOT use your hand to locate it. Use a piece of cardboard or wood.

FIRE AND EXPLOSION

⚠ WARNING

Gasoline is highly flammable and gasoline vapor is explosive. Never smoke while working on vehicle. Keep all open flames away from gasoline tank and lines. Wipe up any spilled gasoline immediately.

Be careful when using gasoline. Do not use gasoline to clean parts. Store only in approved containers away from sources of heat or flame.

VENTILATION



⚠ WARNING

Vehicle exhaust contains lethal fumes. Breathing these fumes, even in low concentrations, can cause death. Never operate a vehicle in an enclosed area without venting exhaust to the outside.

TORQUE CHART

⚠ CAUTION

Read instructions before assembling. Fasteners should be finger tight until instructed to tighten according to the torque chart. Use standard methods and practices when attaching snowplow including wearing proper personal protective safety equipment.

| Recommended Fastener Torque Chart (Ft.-Lb.) | | | |
|---|---|---|---|
| Size |  SAE Grade 2 |  SAE Grade 5 |  SAE Grade 8 |
| 1/4-20 | 6 | 9 | 13 |
| 5/16-18 | 11 | 18 | 28 |
| 3/8-16 | 19 | 31 | 46 |
| 3/8-24 | 24 | 46 | 68 |
| 7/16-14 | 30 | 50 | 75 |
| 1/2-13 | 45 | 75 | 115 |
| 9/16-12 | 66 | 110 | 165 |
| 5/8-11 | 93 | 150 | 225 |
| 3/4-10 | 150 | 250 | 370 |
| 7/8-9 | 150 | 378 | 591 |
| 1-8 | 220 | 583 | 893 |
| Metric Grade 8.8 (Ft.-Lb.) | | | |
| Size | Torque | Size | Torque |
| M 6 | 7 | M 12 | 60 |
| M 8 | 17 | M 14 | 95 |
| M 10 | 35 | M 16 | 155 |
| These torque values apply to fasteners except those noted in the instruction. | | | |

BLADE AND A-FRAME ASSEMBLY

Blade Assembly and A-Frame

1. Place some cardboard or wood supports on the floor where the blade will be assembled. Remove the blade halves from the pallet. Place face down on the cardboard or wood with the hinges facing each other. Push the blade halves together so that the holes in the hinges are aligned.
2. Insert the A-frame assembly between the blade halves so the flat hinges on the A-frame straddle the flat hinges on the blade. Slide the pivot pin through all the hinges once all the hinge holes are aligned. Install a 1/4" x 2" slotted spring pin through the bottom of the pivot pin.

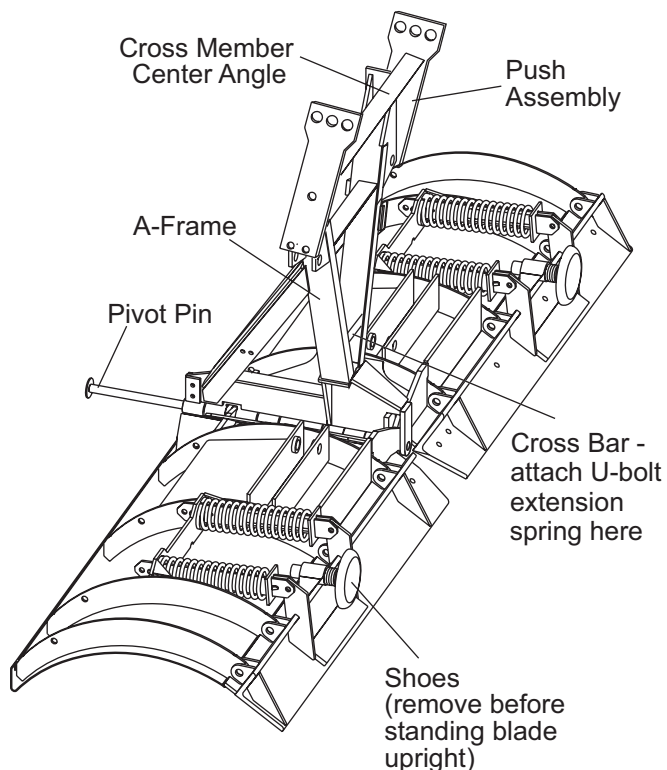

3. Install the push assembly to the outside of the A-frame ears with the flat side of the cross member center angle up.

4. Measure the distance between the center of the connecting pin hole of the vehicle pushplate and the ground. Install two 5/8" x 2" Gr. 8 flanged cap screws into the front holes of the push assembly and A-frame from the outside. See table below to determine which hole to use. Secure with two 5/8" Gr. 8 flanged nuts. Tighten the two fasteners until snug. Do not torque at this time.

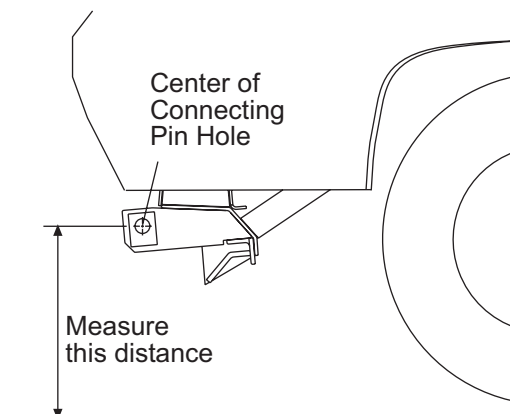

| Push Plate Height (hole center to ground) | Front Hole |
|--|------------|
| 19-1/2" to 13-3/4" (typical) | A |
| 13-3/4" to 11-1/2" | B |

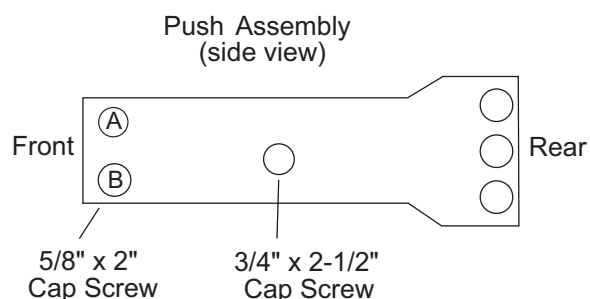

5. Install the 3/4" x 2-1/2" Gr. 8 cap screws in the center holes of the push assembly and through the slot in the A-frame from the outside. Install the 3/4" Gr. 8 flange nuts on the cap screws, finger tight.

28888 V

NOTE: For 9-1/2' EZ-V® blades, install blade stop kit 26634 before attaching angle rams.

6. **On 9-1/2' EZ-V blades only:** Prepare for the installations of the blade stops as follows:

Attach the blade stops to the A-frame by aligning the rear anchor pin holes with the angle ram anchor pin holes in the A-frame and temporarily inserting the angle ram anchor pins.

Using the bolt hole in the blade stop, mark the position of the attaching holes in the A-frame channels. Remove the blade stops and drill the holes in the A-frame channels.

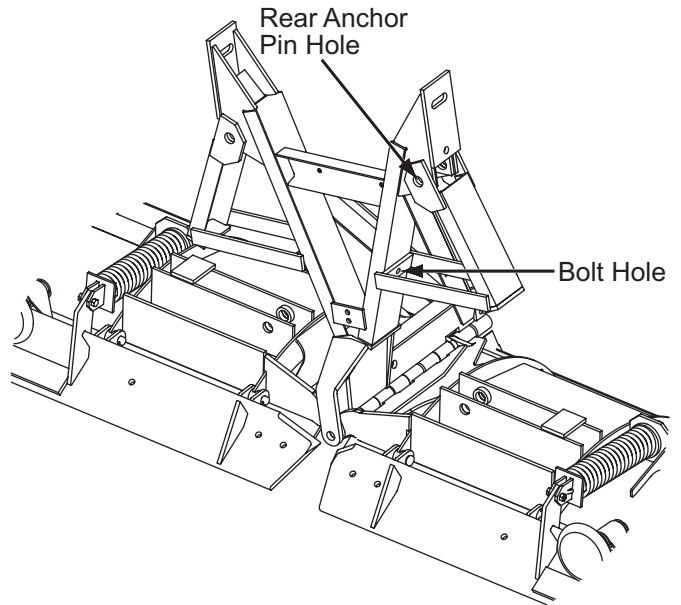

Angle Rams and Hoses

Do not use thread sealant/tape on hoses and fittings. This could damage product.

1. Remove threaded plugs from rams using an Allen wrench.
2. Attach fittings (90°) to rams. These should be parallel to the ram.

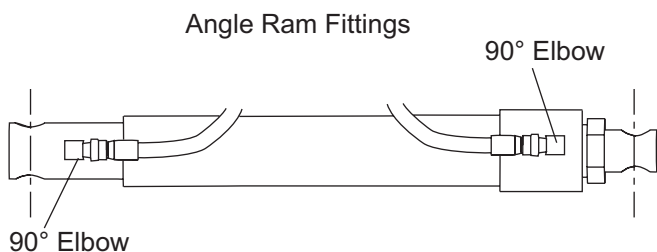

3. Attach 36" hoses to fittings in angle rams. Tighten hoses to the fittings until finger tight.
4. Secure the rams to the wings with anchor pins and cotter pins.

On 9-1/2' EZ-V blades only: Install the blade stops over the rams, and bolt the blade stops to the A-frame using 1/2" x 1-1/2" cap screws and 1/2" locknuts. Swing the A-frame into place such that the rams and blade stops align with the anchor pin holes in the A-frame.

5. Attach the angle rams to the A-frame with the two anchor pins and cotter pins. Position the rams so the fittings face inward, toward the A-frame.

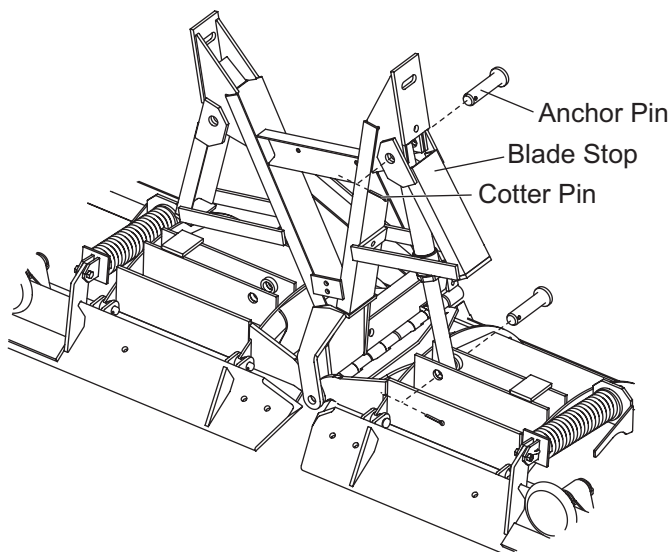

Extension Spring

1. Place U-bolt on extension spring. Place 3/8" nut on each side of U-bolt. Place U-bolt through cross bar on A-frame (see illustration on page 5). Place lock washers and 3/8" nuts on U-bolt and tighten.

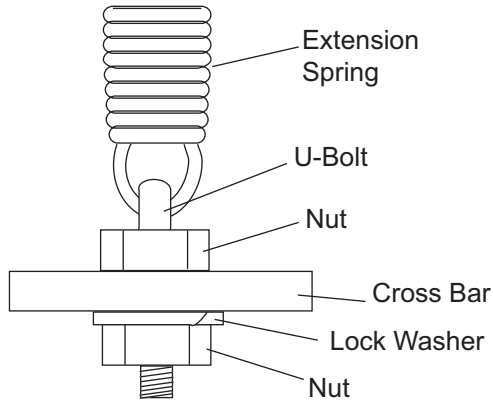

2. Remove shoes and stand the blade up.

Center Deflector

1. Slide the center deflector into place over the top of the hinge.

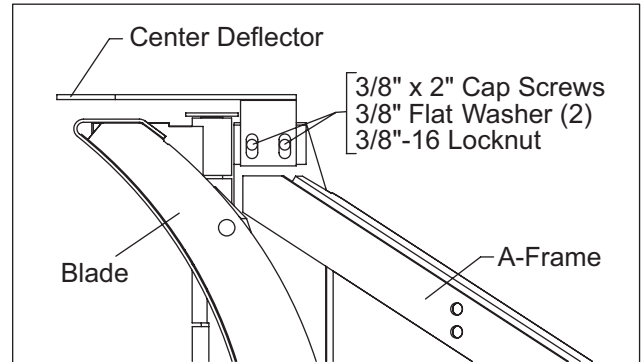

2. Fasten the center deflector to the A-frame using two 3/8" x 2" Gr. 5 cap screws, four 3/8" flat washers (two on each side of deflector) and two 3/8" locknuts.
3. Allow 1/2" clearance between the blade and the center deflector. Torque the two 3/8" fasteners on the center deflector to 31 ft-lb.
4. Install a blade guide on each end of the top of the blade. For each guide, put one washer and one nut on either side of the blade.

HEADGEAR ASSEMBLY

Jack and Headgear Assembly

1. Install the jack by pulling the jack lock out and inserting the jack up through the slot in the headgear. Release the jack lock to hold the jack in place. Attach the jack handle to the jack with a 3/8" lock washer and nut.

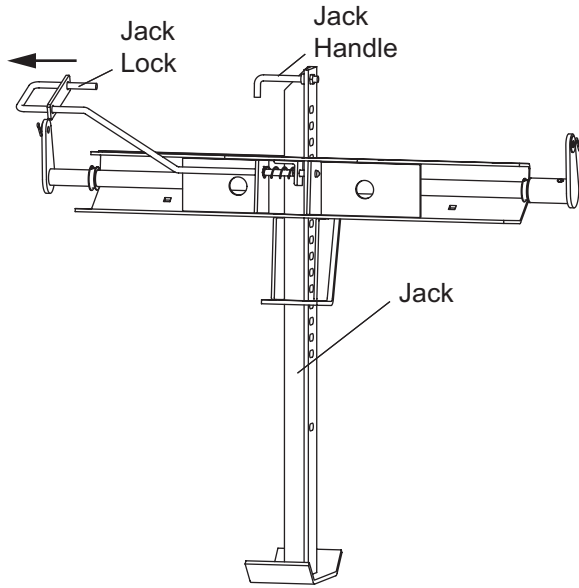

2. Align holes in headgear assembly with a hole in the A-frame pushers. Hole selection is determined by distance from center of the connecting pin hole to the ground. Refer to table below.

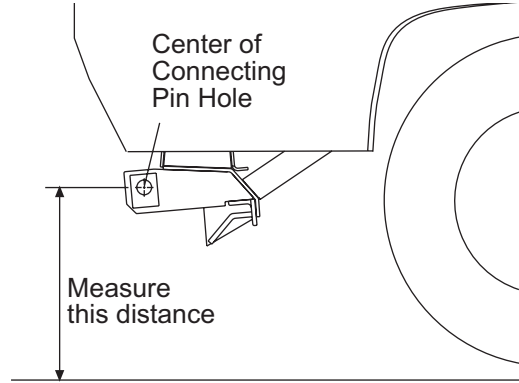

| Push Plate Height (hole center to ground) | Rear Hole |
|--|-----------|
| 18" to 19-1/2" | Top |
| 18" to 15-1/4" (typical) | Middle |
| 15-1/4" to 11-1/2" | Bottom |

- Attach the A-frame to the headgear assembly with two step pins, 1" flat washers and 1/4" x 1-1/2" cotter pins. Insert the step pins from the outside of headgear. Insert 1" flat washer between the headgear A-frame ear and the outside of the push assembly. Verification of proper A-frame position will be made during Final Adjustments at the end of these instructions.

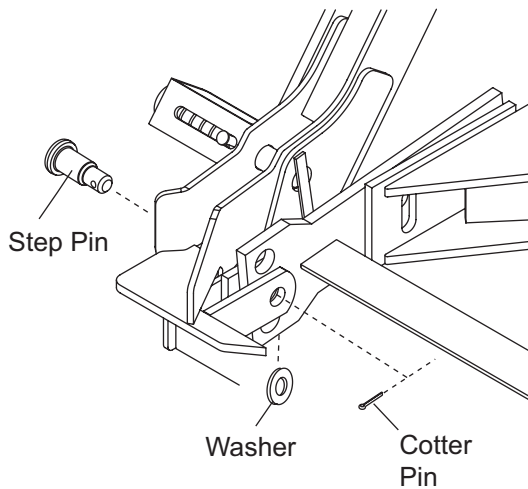

- Install a 3/8" U-bolt through a link in one end of the lift chain. Attach U-bolt and chain to the holes on the driver-side A-frame brace with 3/8" lock washers and nuts. Tighten. The other end of the lift chain will be attached to the passenger side A-frame brace after hydraulic unit is installed.

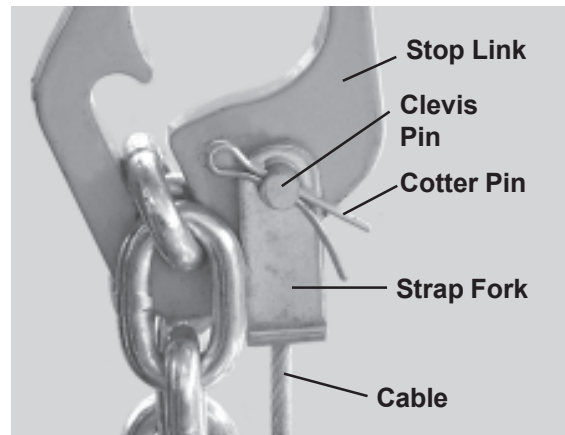

- Insert the cable down through the hole in the strap fork. Attach the strap fork to the hole in the stop link on the lift arm with a 3/8" x 1" clevis pin and 1/8" x 1" cotter pin. Slip the cable thimble onto the top loop in the spring previously installed in the front of the A-frame.

NOTE: The slotted end of the thimble may need to be opened to slip it onto the loop. Fully close the slot after attaching the thimble to the spring.

- Loop the end of the cable around the thimble. Pull the cable up against the thimble until the slack is removed. Attach the end of the cable back onto itself with two cable clamps loosely installed close to the thimble as shown.



Due to varying vehicle heights, the length of the cable must be adjusted for the vehicle in the Final Adjustments section at the end of these instructions.

Lift Ram and Hose Assembly

Do not use thread sealant/tape on hoses and fittings. This could damage products

1. Remove plug from ram port.
2. Turn the jam nut on the fitting as far back as possible.

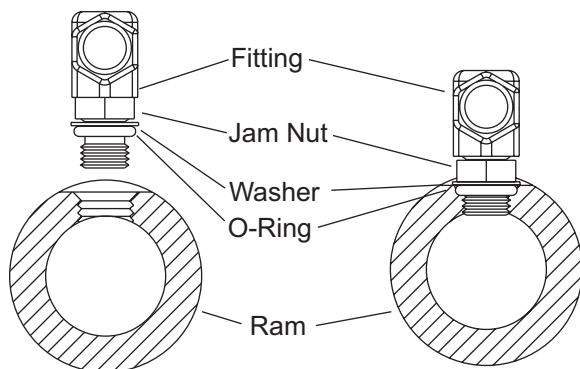

3. Lubricate the O-ring with clean hydraulic oil.
4. Screw fitting into port by hand as far as it will go. The washer should contact port face and shoulder of the jam nut threads.
5. Unscrew fitting to proper position, no more than one full turn.
5. Use one wrench to hold the fitting body in position and tighten the jam nut with another wrench until the washer again contacts port face. Tighten 1/8 to 1/4 turn to lock fitting in place.
6. Attach 18" hose to lift ram elbow.

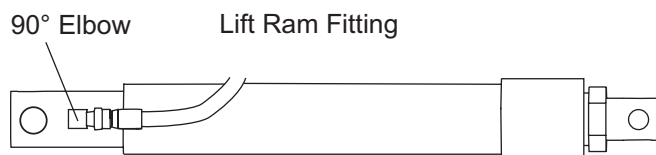

7. Attach lift ram to the headgear using one 1" x 3-5/16" clevis pin and 1/4" x 1-1/2" cotter pin. Attach lift ram to the lift arm using one 1" x 3-5/16" heat treated (head marked "HT") clevis pin and 1/4" x 1-1/2" cotter pin. Orient ram port to driver side.

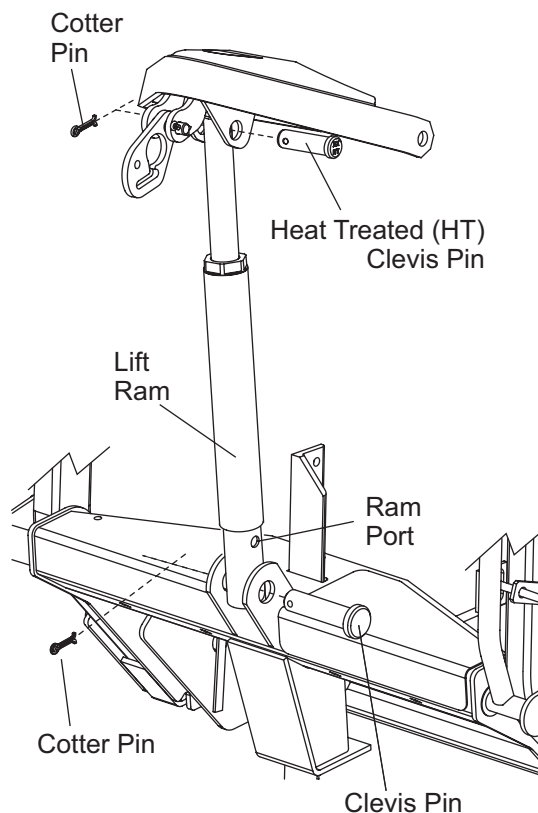

Mounting Hydraulic Unit

1. Bolt the Insta-Act® hydraulic unit to the headgear using two 1/4" x 3" cap screws, flat washers, and locknuts.

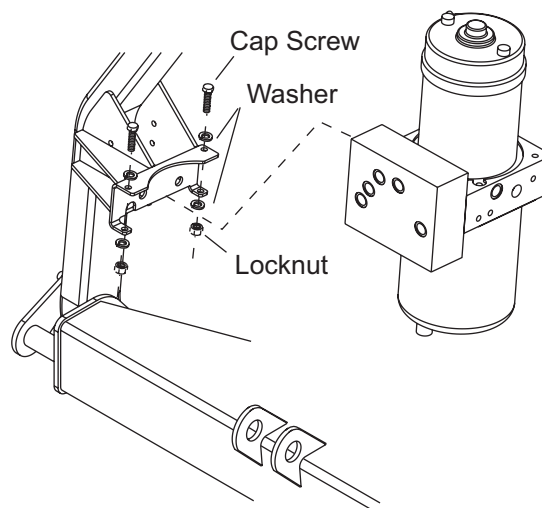

28888 V

2. Install hydraulic hose fittings right to left (A–E) as indicated in the illustration below. Remove the plugs from the angle ports, lift port, and the 3/8" NPTF plug from the breather port. Screw a 90° swivel elbow into the lift port and a 3/8" x 90° street elbow into the breather port. Screw the 45° elbows into the angle ports.
3. Looking at the front of the vehicle, orient the 45° swivel elbows in the angle ports as shown. The 90° swivel in the lift port should be at 1 o'clock. The 3/8" x 90° street elbow in the breather port should point straight up. Screw the breather into the street elbow.
4. Route hydraulic hoses as shown. In order to minimize the possibility of hose damage, route all angle ram hoses from the ram up to the hydraulic unit.

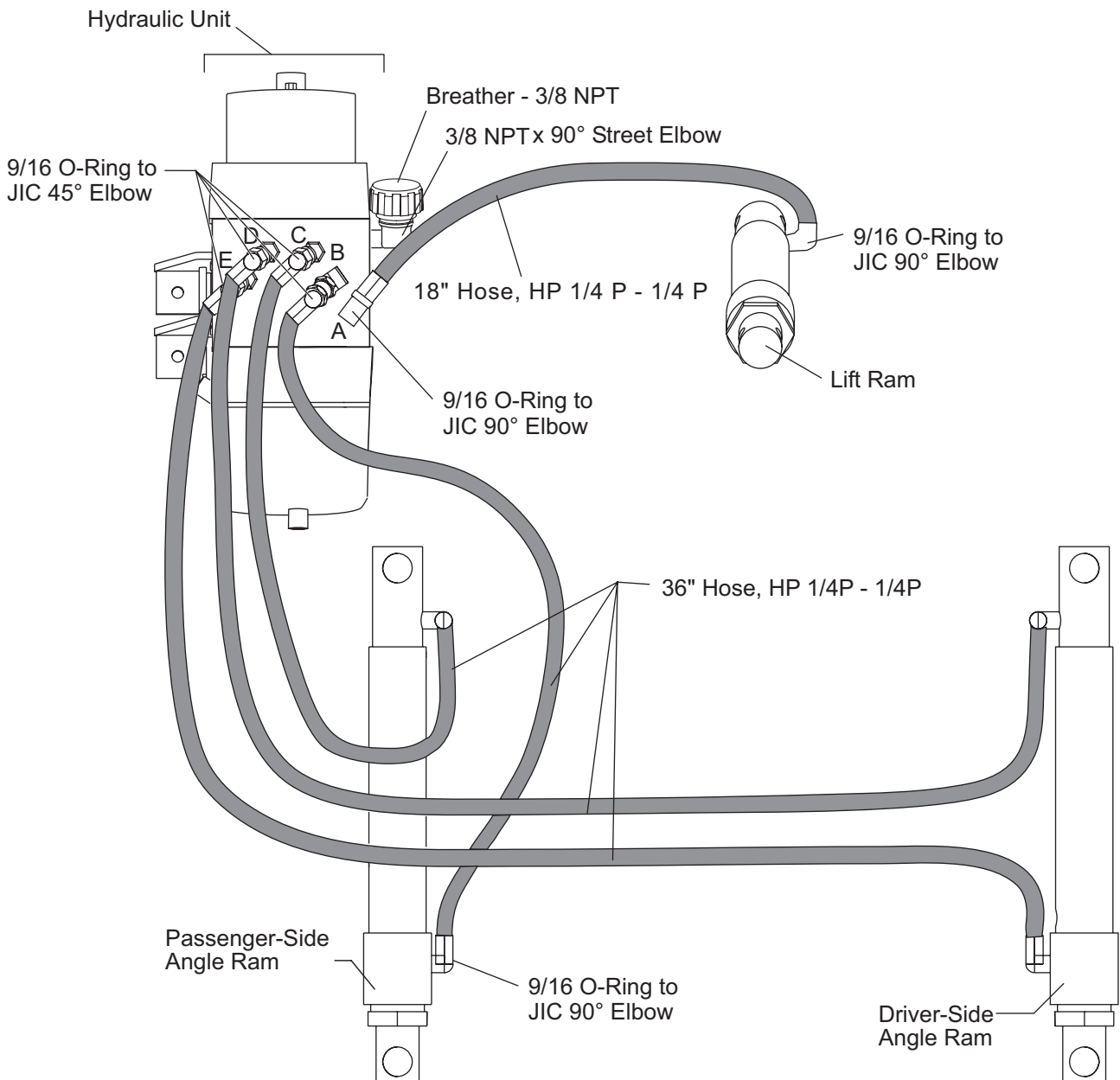

CONTROL AND LIGHT HARNESS INSTALLATION

NOTE: Use dielectric grease to prevent corrosion on all electrical connections. Fill receptacles and lightly coat ring terminals and blades before assembly.

1. Remove the valve covers, and connect the snowplow control harness to the valve coil terminals according to the instructions inside the valve covers.

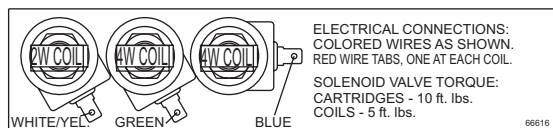
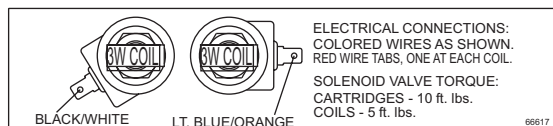
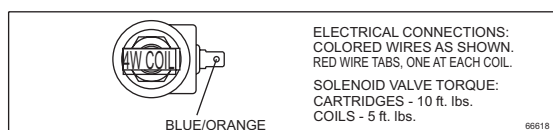

NOTE: The strain relief must be inside the covers to prevent unnecessary strain on the solenoid connectors.

2. Apply anti-seize lubricant to the fasteners and reinstall the valve covers.
3. Attach the snowplow battery cable to the motor terminals. Connect the black and red striped wire to the POSITIVE (+) terminal. Connect the black wire to the NEGATIVE (-) terminal.
4. Cable tie harnesses and battery cable to the headgear as shown on the following page.

NOTE: Snowplow lighting and control harnesses plug into one another for storage.

HEADLAMP INSTALLATION

⚠ WARNING

Your vehicle must be equipped with snowplow headlamps and directional lights.

If installation instructions were included with the headlamps, follow them now.

1. Slide a headlamp swivel onto the threaded stem on the underside of the driver-side headlamp assembly. The park/turn lamp should be to the outside of the headlamp.
2. Mount the headlamp to the headgear light bracket as shown. Secure with a lock washer and nut.

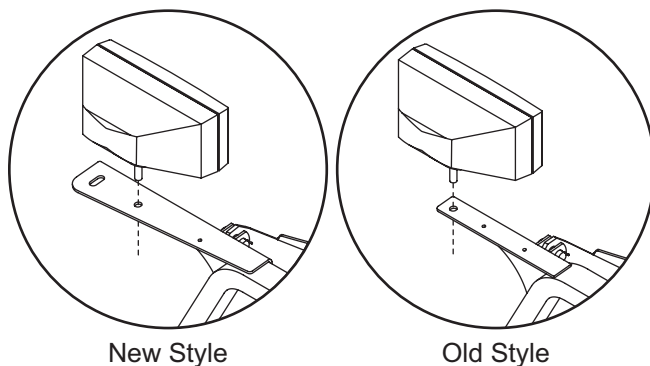

3. Repeat steps 1 and 2 on the passenger side.
4. Route the snowplow lighting harness as shown, connecting the black/orange ground wire to the NEGATIVE (-) motor terminal. Secure the snowplow lighting harness to the headgear using cable ties as needed.
5. Read, follow, and remove the headlamp label if one is present.

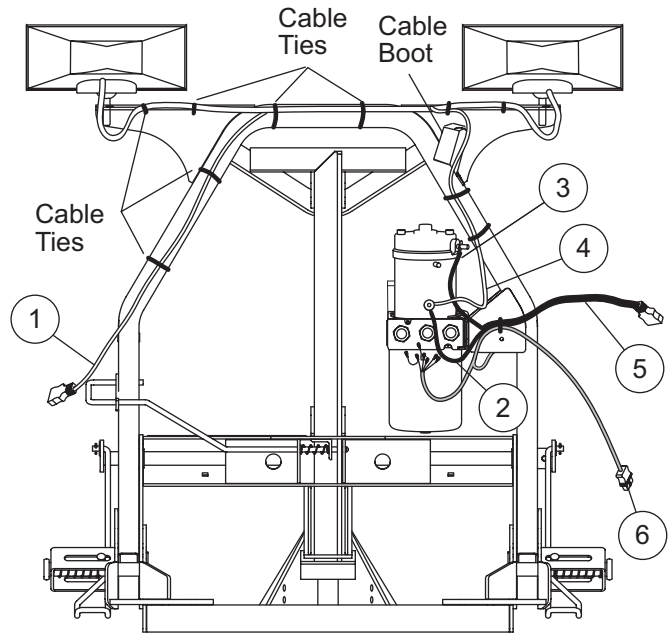

| Cable Routing | |
|----------------------|--|
| 1 | Snowplow Lighting Harness |
| 2 | Black Wire |
| 3 | Black/Red Wire (connected to POSITIVE (+) motor terminal) |
| 4 | Black/Orange Ground Wire (connected to NEGATIVE (-) motor terminal) |
| 5 | Snowplow Battery Cable, shrouded plug (plug into cable boot for storage) |
| 6 | Snowplow Control Harness (plug into snowplow lighting harness for storage) |

PUSH ASSEMBLY ADJUSTMENT

NOTE: The vehicle is needed to complete the installation. Do all necessary installation to the vehicle at this time, if not already done. Add ballast and equip vehicle as it will be used to plow snow.

1. Attach the snowplow to the vehicle according to the instructions on the headgear. Manually place the blade to the "scoop" position. With shoes removed, and the plow fully lowered, place a 1/4" spacer between the wings and floor as shown.

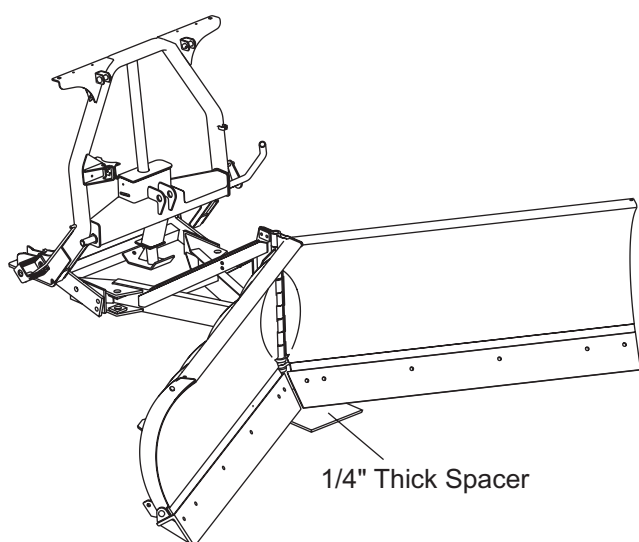

2. Tighten the two 5/8" fasteners holding the push assembly to the A-frame.
3. Detach the snowplow from the truck, according to the instructions on the headgear.
4. Remove the 3/4" nuts from the cap screws in the center holes on the push assembly and install the locking plate as illustrated. Slide the locking plates as far forward as possible. Reinstall the 3/4" locknuts and tighten.
5. Make sure all flanged bolts (Gr. 8) and nuts (Gr. 8) on the A-frame are fastened to the proper torque. Torque the 5/8" fasteners to 250 ft-lb. Torque 3/4" fasteners to 350 ft-lb.

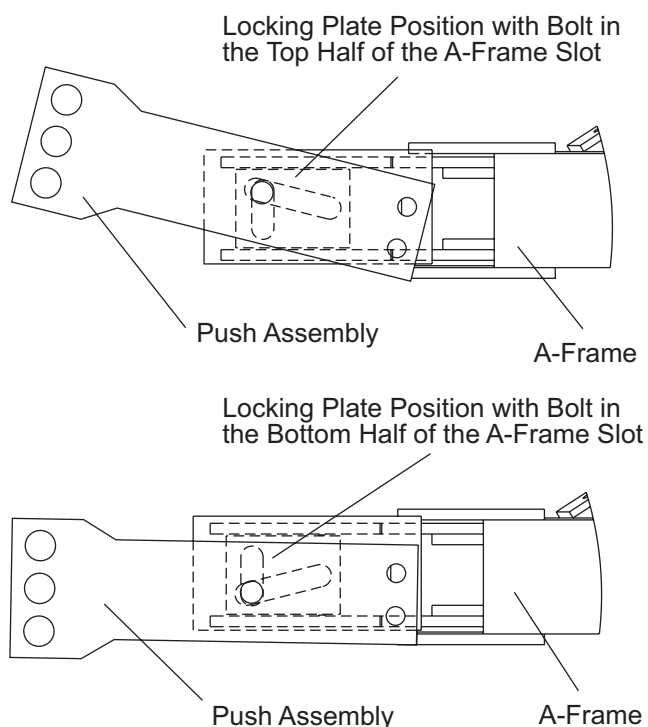

RUBBER FLAP ASSEMBLY

1. Install one mounting bracket to the back of each base angle, using four 1/2" x 2" cap screws and 1/2" locknuts.

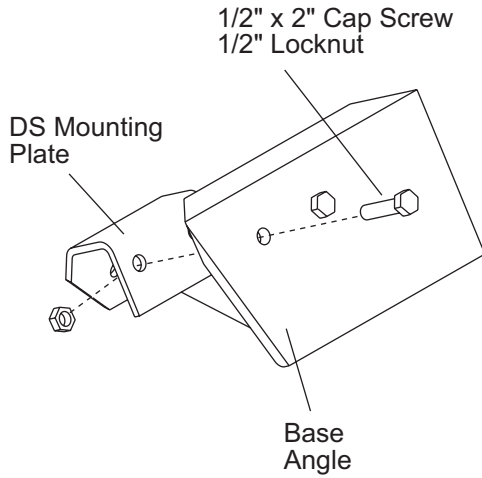

2. Adjust wings so they are in line with each other or slightly forward in the scoop position.
3. Place 1/2" washer on 1/2" x 2-1/2" cap screw and insert cap screw into a hole in the rubber flap. The rubber flap is mounted with the longest edge facing the ground.

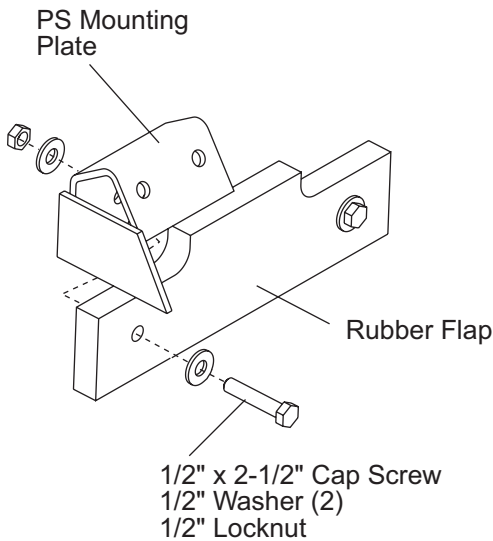

4. Place rubber flap against rear inside surface of the mounting brackets and align holes in flap and brackets.
5. Insert the cap screw through the hole in the back plate of the mounting bracket. Add 1/2" washer and 1/2" locknut. Tighten locknut until washer slightly deforms the rubber surface.
6. Insert the second 1/2" cap screw through the rubber flap and mounting plate weldment using the same washer and locknut assembly as mentioned above.

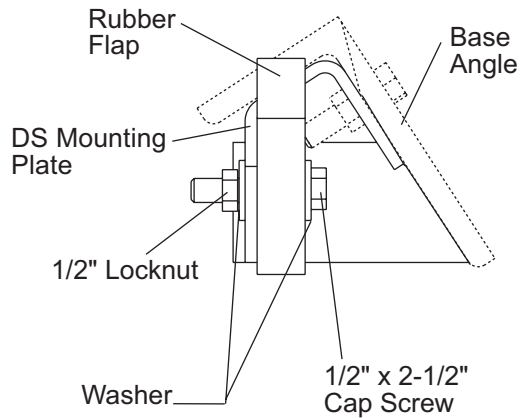

FINAL ADJUSTMENTS

⚠ WARNING

Keep 8' clear of the blade when it is being raised, lowered or angled. Do not stand between the vehicle and blade or directly in front of the blade. If the blade hits or drops on you, you could be seriously injured.

1. Detach the snowplow from the vehicle. Push the headgear toward the blade as far as it will go with the lift ram fully retracted. The blade and headgear will be in the stacking position. If the A-frame interferes with the hydraulic unit or the lift arm, install the A-frame stop. If no interference, move on to step 3.

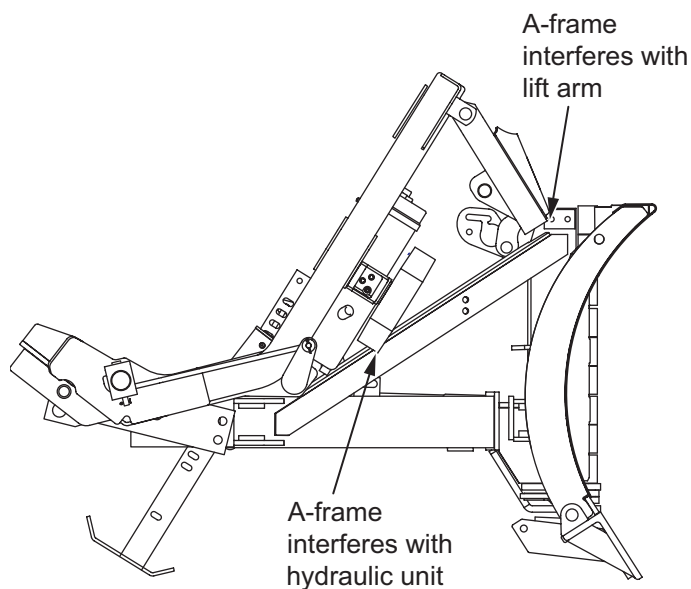

2. Install four 3/8" x 1" carriage bolts through cross channel of the headgear as shown in top of next column. Install an A-frame stop on each side as shown. Torque the two 3/8" locknuts to 31 ft-lb.

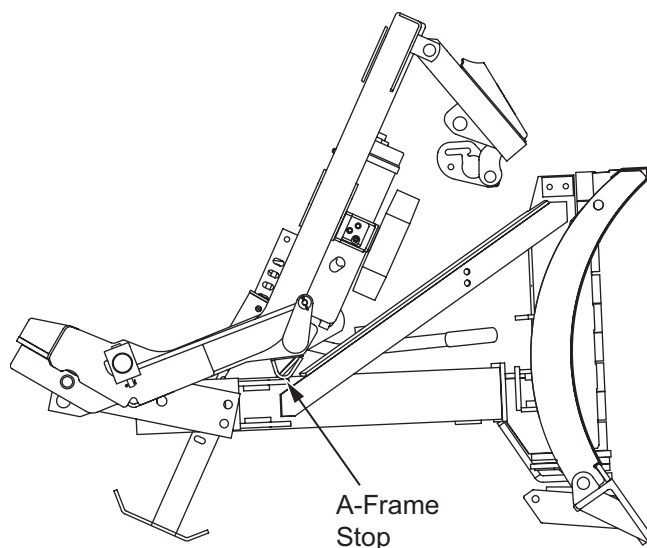
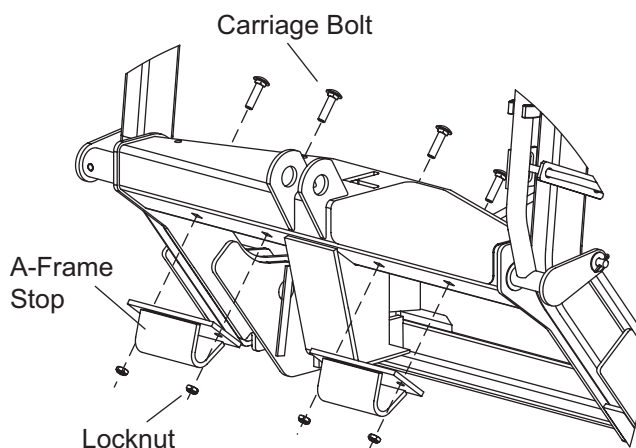

3. Complete installation of lift chain by inserting loose end of lift chain through stop link on the lift arm. Fasten to opposite holes in the A-frame brace using a 3/8" U-bolt, lock washer, and nut. Hand tighten.
4. Complete electrical installation in vehicle and install control. Attach snowplow to vehicle.

⚠ CAUTION

Do not mix different types of hydraulic fluid. Some fluids are not compatible and may cause performance problems and product damage.

NOTE: Add fluid only when all rams are retracted.

5. With snowplow in vee position and lift ram fully retracted, fill the reservoir with hydraulic fluid. Replace fill plug.
6. Turn control on and completely extend and retract the driver-side wing several times. With all rams fully retracted, turn control off.

⚠ CAUTION

DO NOT raise blade as this may cause pump cavitation.

7. Fill reservoir to top of fill hole and replace fill plug.
8. Repeat steps 6 and 7 for the passenger side wing.
9. Turn control on and raise and lower the snowplow several times. Activate control float function and manually collapse lift ram all the way after each lowering of the blade. With all rams fully retracted, turn control off.
10. Fill reservoir to top of fill hole and replace fill plug.

FLUID CAPACITY

- Insta-Act® Unit Reservoir 1-3/4 quarts
- Insta-Act® System Total 2-3/4 quarts

11. With plow attached to properly ballasted vehicle and blade lowered to ground, the A-frame should be parallel with the ground. If not, see Push Assembly Adjustment.

12. Attach the snowplow to the vehicle.
13. Adjust the length of the lift chain so the A-frame hits the lower portion of the headgear or A-frame stop when the lift ram is fully raised (10"). Tighten U-bolts.
14. For reliable operation and prevent damage to the 6-1/2" lift arm extension spring, the length of the cable must be adjusted when attached to the vehicle it will be used on. With the lift ram fully collapsed, wrap the cable tightly around the thimble, shorten/lengthen the cable to remove all slack from the cable, then tighten the cable clamps.
15. After adjustment, excess cable should be trimmed off close to the second cable clamp. Cover cut end of cable with electrical tape. Excessive spring tension will make attaching/detaching difficult and overextend the spring.

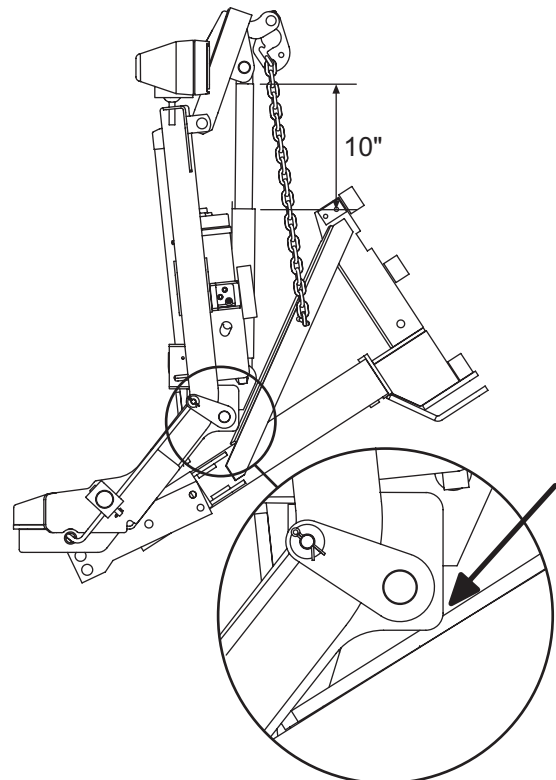

VEHICLE LIGHTING CHECK

1. Check the operation of vehicle and plow lights with plow mounted to vehicle and all harnesses connected.

Turn signals and parking lamps

Parking lamps ON:

- Both vehicle and plow parking lamps should be on at the same time.

Driver-side turn signal ON:

- Both vehicle and plow driver-side turn signal lamps should flash at the same time.

Passenger-side turn signal ON:

- Both vehicle and plow passenger-side turn signal lamps should flash at the same time.

Headlamps

Move vehicle headlamp switch to the ON position. Connecting and disconnecting the headlamp harness plug from the vehicle harness connector should switch between vehicle and plow headlamps as follows:

Headlamp harness plug DISCONNECTED:

- Vehicle headlamps should be on.
- Plow headlamps should be off.

Headlamp harness plug CONNECTED:

- Plow headlamps should be on.
- Vehicle headlamps should be off.

Dimmer switch should dim whichever headlamps are operating. The high beam indicator on the dash should light when either set of headlamps is on high beam.

Daytime Running Lamps (DRLs)

With headlamp switch off, activate the DRLs.

Headlamp harness plug DISCONNECTED:

- Vehicle DRLs should be on.
- Plow headlamps should be off.

Headlamp harness plug CONNECTED AND vehicle uses the headlamp bulbs for DRLs:

- Plow headlamps should be on in DRL mode (with reduced intensity compared to high or low beam).
- Vehicle DRLs should be OFF.

Headlamp harness plug CONNECTED AND vehicle uses lamps **other than** the headlamp bulbs for DRLs:

- Plow headlamps should be on in DRL mode (with reduced intensity compared to high or low beam).
- Vehicle DRLs should be on.
- Vehicle headlamps should be off.

Joystick Control or Hand-Held Control

The control indicator light should light whenever the control ON/OFF switch and the ignition (key) switches are both in the ON position. The plow plugs do not need to be connected to the vehicle harness connectors.

2. Connect all plow and vehicle harnesses. Raise the plow and aim plow headlamps according to the Snowplow Headlamp Beam Aiming instructions included with the headlamps and any state or local regulations.
3. Check aim of vehicle headlamps with plow removed.
4. When the plow is removed from the vehicle, install the plug cover on the vehicle battery cable connector and insert the plow battery cable connector into the cable boot on the plow. On both the vehicle and plow, the lighting harness and control harness connectors plug into one another for storage.

OWNER'S MANUAL PACKET

If the completed plow will be delivered immediately, the Owner's Manual should be reviewed with and given to the purchaser.

If the plow is completed prior to delivery to the purchaser, attach the Owner's Manual Packet to the electrical cable of the cab control for safekeeping.

Fisher Engineering reserves the right under its product improvement policy to change construction or design details and furnish equipment when so altered without reference to illustrations or specifications used. Fisher Engineering or the vehicle manufacturer may require or recommend optional equipment for snow removal. Do not exceed vehicle ratings with a snowplow. Fisher Engineering offers a limited warranty for all snowplows and accessories. See separately printed page for this important information. The following are registered (®) trademarks of Douglas Dynamics, L.L.C.: EZ-V®, FISHER®, Insta-Act®, Minute Mount® 2.

Printed in U.S.A.
