

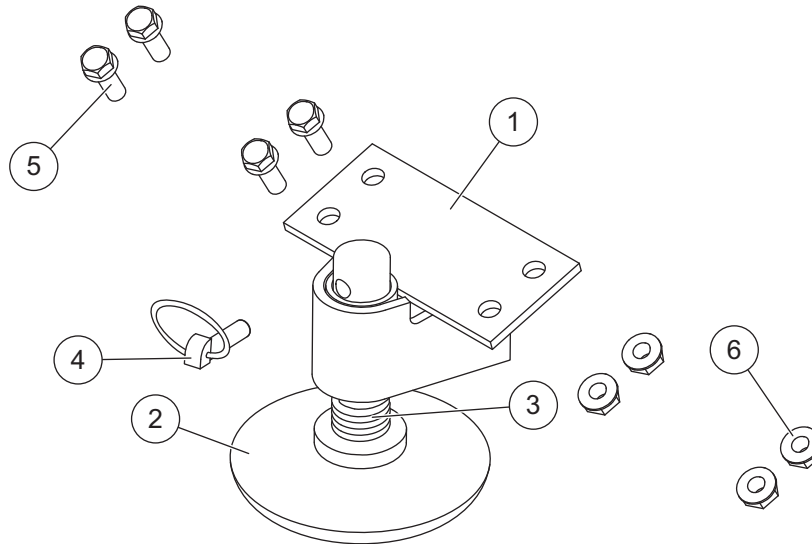

SHOE KIT

SD & HT Series™ Blades

PARTS LIST



27880 Shoe Kit SD & HT Series Blades							
Item	Part	Qty	Description	Item	Part	Qty	Description
1	27871	2	Shoe Bracket LD/SD/HT Series	4	93010	2	Linchpin
2	*26523	2	Shoe Assembly – 6" Solid Cast	ns	26146	1	Bolt Bag
3	307-1	10	Shoe Spacer				
26146 Bolt Bag							
5		8	1/2-13 x 1-1/2 Flange Screw G8	6		8	1/2-13 Hex Flange Locknut GG
* Consists of (1) shoe, (1) 93010 linchpin and (5) 307-1 shoe spacers							
ns = not shown				G = Grade			

⚠ WARNING

Do not exceed GVWR or GAWR, including blade and ballast. The rating label is found on the driver-side vehicle door cornerpost.

⚠ CAUTION

Use standard methods and practices when attaching snowplow and installing accessories including proper personal protective safety equipment.

⚠ CAUTION

Read this document before installing the Shoe Kit.

⚠ CAUTION

See your FISHER® outlet/Web site for specific vehicle application recommendations before installation. Shoe Kit weight information may be found in the Kit Selection Guide.

INSTALLATION INSTRUCTIONS

1. Park the vehicle on a smooth, level, hard surface, such as concrete. Lower the blade to the ground, and turn the control to the "OFF" position. Disconnect the snowplow from the vehicle, or turn the vehicle ignition to the "OFF" position and remove the key.
2. **For SD blades**, position the shoe bracket approximately 1" from the edge of the bolting pad to the base angle ear as shown below.

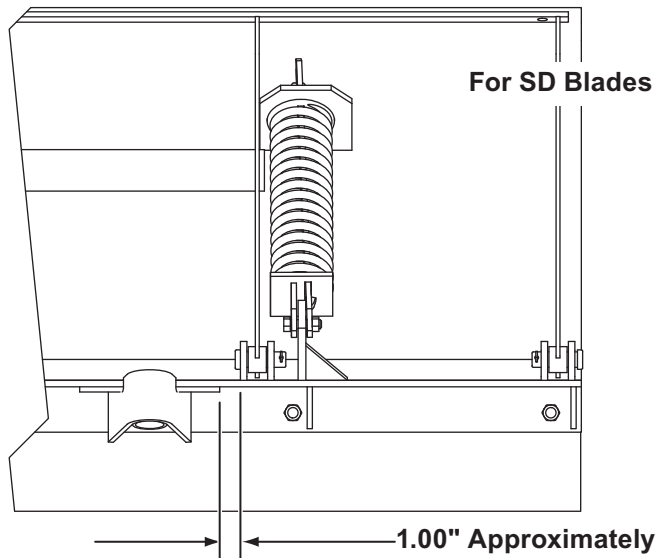

Position the shoe tube against the rear edge of the base angle. **Make sure the shoe bracket is parallel with the base angle.**

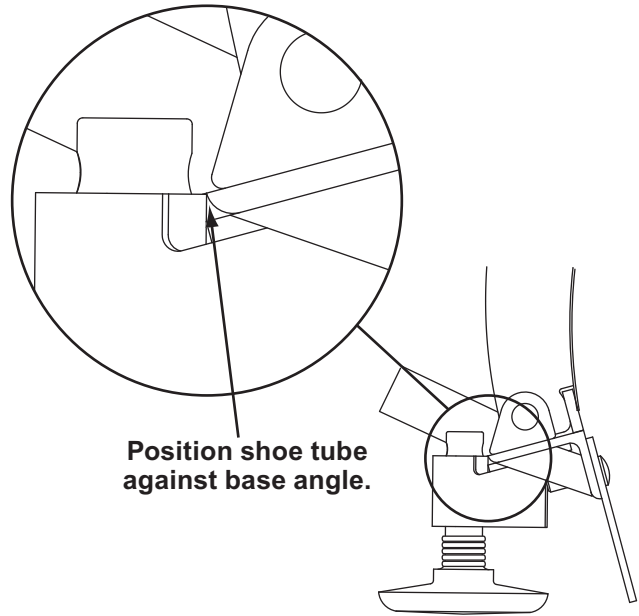

For HT Series™ blades, position the shoe bracket approximately 6" from the outside edge of the blade as shown below.

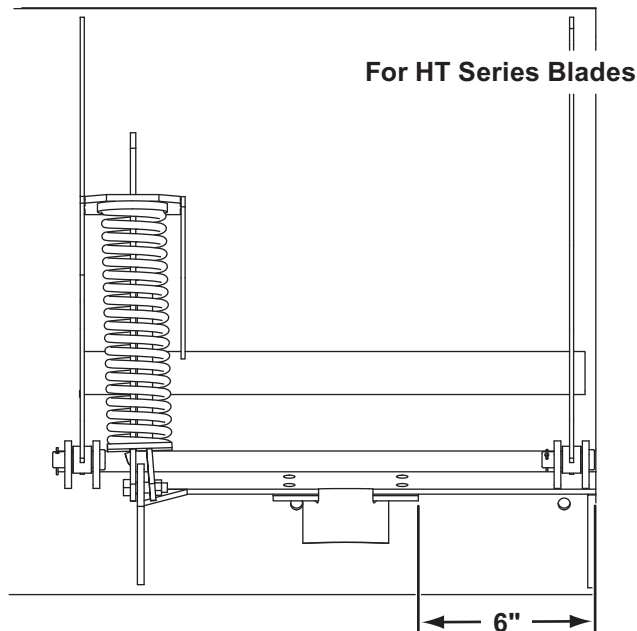

- Using the bracket as a guide, drill four $\frac{17}{32}$ " holes in the base angle. Fasten with four $1\frac{1}{2}$ " screws and $\frac{1}{2}$ " locknuts. Tighten to 115 ft-lb.

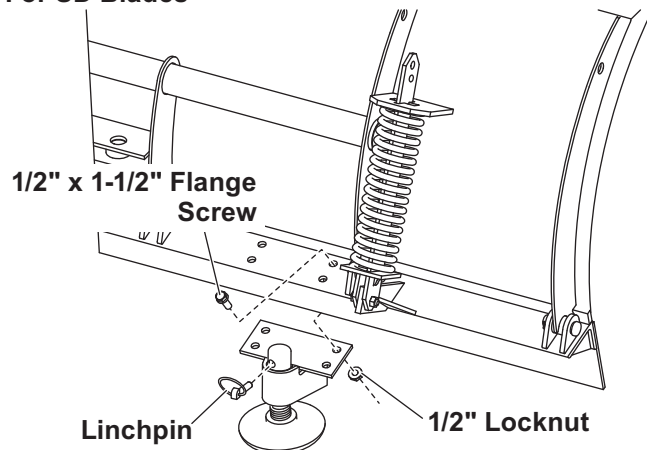
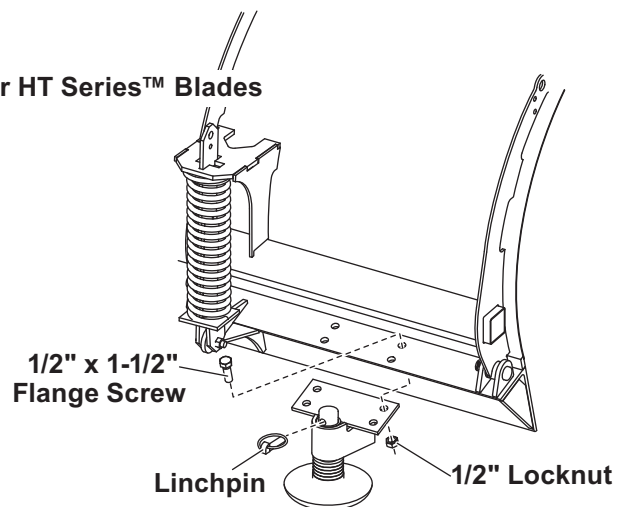
For SD Blades**For HT Series™ Blades**

- Repeat on the opposite side.
- Install the shoes, spacers and pins.

Copyright © 2009 Douglas Dynamics, L.L.C. All rights reserved. This material may not be reproduced or copied, in whole or in part, in any printed, mechanical, electronic, film or other distribution and storage media, without the written consent of Fisher Engineering. Authorization to photocopy items for internal or personal use by Fisher Engineering outlets or snowplow owner is granted.

Fisher Engineering reserves the right under its product improvement policy to change construction or design details and furnish equipment when so altered without reference to illustrations or specifications used. Fisher Engineering or the vehicle manufacturer may require or recommend optional equipment for snow removal. Do not exceed vehicle ratings with a snowplow. Fisher Engineering offers a limited warranty for all snowplows and accessories. See separately printed page for this important information. The following are registered (®) or unregistered (™) trademarks of Douglas Dynamics, L.L.C.: FISHER®, HT Series™.

Printed in U.S.A.