



Minute² Mount[®]

SYSTEM

MOUNT KIT

Nissan Titan

2004-09

Installation Instructions

⚠ CAUTION

Read this document before installing the snowplow.

⚠ CAUTION

See your FISHER[®] outlet/Web site for specific vehicle application recommendations before installation. The Kit Selection Guide has specific vehicle and snowplow requirements.

SAFETY DEFINITIONS

⚠ WARNING

Indicates a potentially hazardous situation that, if not avoided, could result in death or serious personal injury.

⚠ CAUTION

Indicates a potentially hazardous situation that, if not avoided, may result in minor or moderate injury. It may also be used to alert against unsafe practices.

NOTE: Indicates a situation or action that can lead to damage to your snowplow and vehicle or other property. Other useful information can also be described.

WARNING/CAUTION AND INSTRUCTION LABELS

Become familiar with and inform users about the warning labels on the back of the blade and the instruction label on the headgear.

NOTE: If labels are missing or cannot be read, see your sales outlet.

Warning/Caution Label

⚠ WARNING

LOWER BLADE WHEN VEHICLE IS PARKED.
DO NOT EXCEED GVWR OR GAWR INCLUDING BLADE AND BALLAST.
REMOVE BLADE ASSEMBLY BEFORE PLACING VEHICLE ON HOIST.

⚠ CAUTION

READ OWNER'S MANUAL BEFORE OPERATING OR SERVICING SNOWPLOW.
TRANSPORT SPEED SHOULD NOT EXCEED 45 MPH. FURTHER REDUCE SPEED UNDER ADVERSE TRAVEL CONDITIONS.
PLOWING SPEED SHOULD NOT EXCEED 10 MPH.
SEE YOUR SALES OUTLET/WEB SITE FOR SPECIFIC VEHICLE APPLICATION RECOMMENDATIONS.

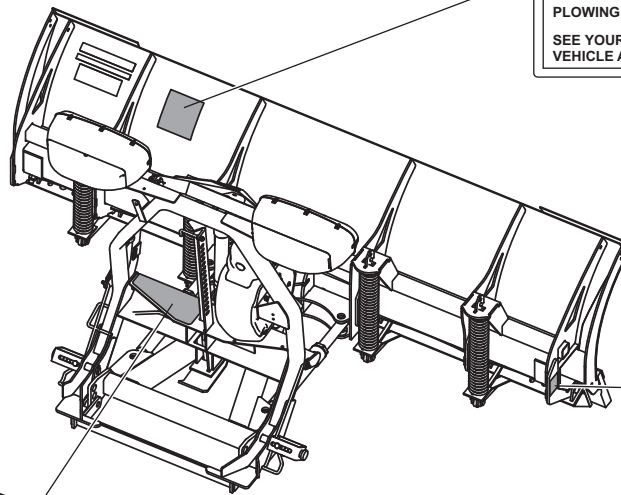

Multiple Pinch Points Label



**XLSTM™ Blades Only
(both sides)**

Instruction Label

1. Push **Pin Release Handle** down to pull out **Connecting Pins**.

2. Drive vehicle slowly to engage **Pushplates** into **Attachment Arms**.

3. Stand in front of blade. Fully raise **Pin Release Handle** to release **Connecting Pins**.

4. Push **Headgear** toward vehicle to allow **Connecting Pins** to fully engage **Pushplates**. If unable to push **Headgear** from in front of blade, stand in front of **Headgear** on driver side and push **Headlamp Bracket**.

5. Pull out **Jack Lock**. Push **Pin Release Handle** into **Stop**.

6. While holding **Jack Lock** out, use **Jack Handle** to raise **Jack** fully. Release **Jack Lock**.

7. Attach all electrical connectors.

1. Place control in Lower/Float to put blade down.

2. Pull and hold **Jack Lock** out. **Jack** will drop to ground. Then pull **Pin Release Handle** away from **Stop** and **Jack Lock**. Release **Jack Lock**. Verify **Jack** is locked by trying to lift **Jack**.

3. Stand in front of blade. While pushing **Headgear** toward vehicle with left hand, push **Pin Release Handle** down to disengage **Connecting Pins**. Make sure **Connecting Pins** are fully retracted. If unable to push **Headgear** from in front of blade, stand in front of **Headgear** on driver side and push **Headlamp Bracket**.

4. Detach all electrical connectors.

U.S. patents 5,353,530; 5,420,480; 5,638,618; 5,899,007; 6,253,470; 6,408,549; 6,944,978; 7,400,058; 7,430,821; RE35,700; CAN patents 2,060,425; 2,194,922; 2,228,753; 2,356,036; and other patents pending.

Read Owner's Manual for complete instructions.

ATTACH
DETACH

SAFETY PRECAUTIONS

Improper installation and operation could cause personal injury and/or equipment and property damage. Read and understand labels and the Owner's Manual before installing, operating or making adjustments.

⚠ WARNING

Lower blade when vehicle is parked. Temperature changes could change hydraulic pressure, causing the blade to drop unexpectedly or damaging hydraulic components. Failure to do this could result in serious personal injury.

⚠ WARNING

The driver shall keep bystanders clear of the blade when it is being raised, lowered or angled. Do not stand between the vehicle and the blade or within 8 feet of a moving blade. A moving or falling blade could cause personal injury.

⚠ WARNING

Keep hands and feet clear of the blade and A-frame when mounting or removing the snowplow. Moving or falling assemblies could cause personal injury.

⚠ WARNING

Do not exceed GVWR or GAWR including the blade and ballast. The rating label is found on the driver-side vehicle door cornerpost.

⚠ WARNING

To prevent accidental movement of the blade, always turn the control OFF whenever the snowplow is not in use. The power indicator light will turn OFF.

⚠ WARNING

Remove blade assembly before placing vehicle on hoist.

⚠ CAUTION

Refer to the Kit Selection Guide for minimum vehicle recommendations and ballast requirements.

PERSONAL SAFETY

- Remove ignition key and put the vehicle in park or in gear to prevent others from starting the vehicle during installation or service.
- Wear only snug-fitting clothing while working on your vehicle or snowplow.
- Do not wear jewelry or a necktie, and secure long hair.
- Wear safety goggles to protect your eyes from battery acid, gasoline, dirt and dust.
- Avoid touching hot surfaces such as the engine, radiator, hoses and exhaust pipes.
- Always have a fire extinguisher rated BC handy, for flammable liquids and electrical fires.

FIRE AND EXPLOSION

⚠ WARNING

Gasoline is highly flammable and gasoline vapor is explosive. Never smoke while working on vehicle. Keep all open flames away from gasoline tank and lines. Wipe up any spilled gasoline immediately.

Be careful when using gasoline. Do not use gasoline to clean parts. Store only in approved containers away from sources of heat or flame.

CELL PHONES

A driver's first responsibility is the safe operation of the vehicle. The most important thing you can do to prevent a crash is to avoid distractions and pay attention to the road. Wait until it is safe to operate Mobile Communication Equipment such as cell phones or two-way radios.

VENTILATION



⚠ WARNING

Vehicle exhaust contains lethal fumes. Breathing these fumes, even in low concentrations, can cause death. Never operate a vehicle in an enclosed area without venting exhaust to the outside.

TORQUE CHART

⚠ CAUTION

Read instructions before assembling. Fasteners should be finger tight until instructed to tighten according to the torque chart. Use standard methods and practices when attaching snowplow including proper personal protective safety equipment.

Recommended Fastener Torque Chart (ft-lb)			
Size	Torque		
	 SAE Grade 2	 SAE Grade 5	 SAE Grade 8
1/4-20	6	9	13
5/16-18	11	18	28
3/8-16	19	31	46
3/8-24	24	46	68
7/16-14	30	50	75
1/2-13	45	75	115
9/16-12	66	110	165
5/8-11	93	150	225
3/4-10	150	250	370
7/8-9	150	378	591
1-8	220	583	893

Metric Grade 8.8 (ft-lb)			
Size	Torque	Size	Torque
M 6	7	M 12	60
M 8	17	M 14	95
M 10	35	M 16	155

These torque values apply to fasteners except those noted in the instruction.

INSTALLATION INSTRUCTIONS

NOTE: For easier assembly and installation, vehicle and all snowplow components should be on a smooth, level, hard surface, such as concrete.

1. If the vehicle is equipped with tow hooks, remove them. Retain the tow hooks and fasteners for reinstallation if the snowplow mount is removed.
2. If the vehicle is equipped with a front skid plate, remove it and the adjoining support brackets and tow hooks. Retain the skid plate, support brackets, tow hooks and fasteners for reinstallation if the snowplow mount is removed. Remove the license plate and connecting bracket assembly from the skid plate and reinstall it to the vehicle's front bumper as located by the preexisting detents.
3. Cut an opening in the splash shield as shown below.

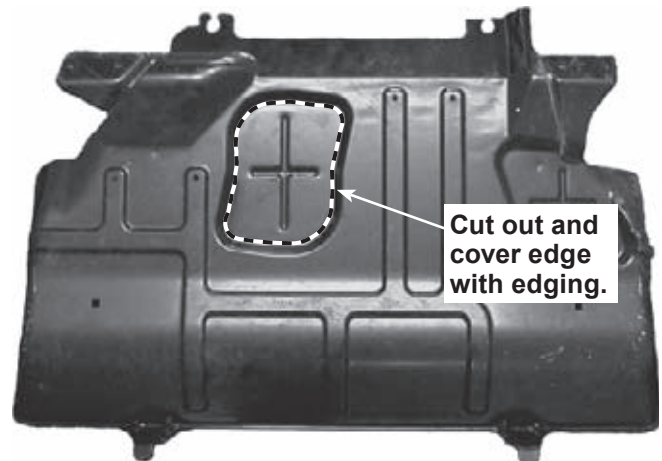

4. Cover the edges of the opening with the edging provided. Reinstall the splash shield with the original fasteners.
5. Position the driver-side mount against the bottom surfaces of the vehicle frame rail while aligning the front mount hole with the tow hook hole. Secure the mount to the frame rail with M12 x 40 cap screws and 1/2" flat washers (supplied with the mount). Hand tighten only.
6. Clamp the rear of the mount against the bottom surface of the vehicle frame rail.
8. Place a 1/2" flat washer onto a 1/2" cap screw with handle and insert the fastener into the slot located on the bottom surface of the vehicle frame rail rearward of the mount. Pass the fastener out through the vehicle frame and mount hole, bending the handle as necessary. Place a 1/2" locknut on the fastener, and hand tighten.

⚠ CAUTION

Use caution not to pinch, cut or drill through any wires or hoses running along the frame rail.

7. Remove the bumper brace to gain access for drilling holes through the vehicle frame rails. Using the rear hole in the mount as a guide, drill a 17/32" hole through the outside wall of the vehicle frame rail.
9. Repeat Steps 5–8 on the opposite side of the vehicle.
10. Install the cross bar using four 1/2" x 1-1/2" cap screws and 1/2" locknuts. Hand tighten fasteners.



11. Fully tighten the passenger-side mount according to the torque chart. Measure the distance between the pushplates. The outside to outside dimension must be $30\text{-}1/4" \pm 1/8"$ (or inside to inside dimension must be $28\text{-}1/2" \pm 1/8"$). Once the specified dimension is reached, fully tighten the driver-side fasteners according to the torque chart.
12. Tighten all fasteners according to the torque chart after achieving the appropriate dimension.
13. Bend or cut the ends of the cap screw handles protruding out from the truck frame.
14. Reinstall the bumper braces on both sides of the vehicle.

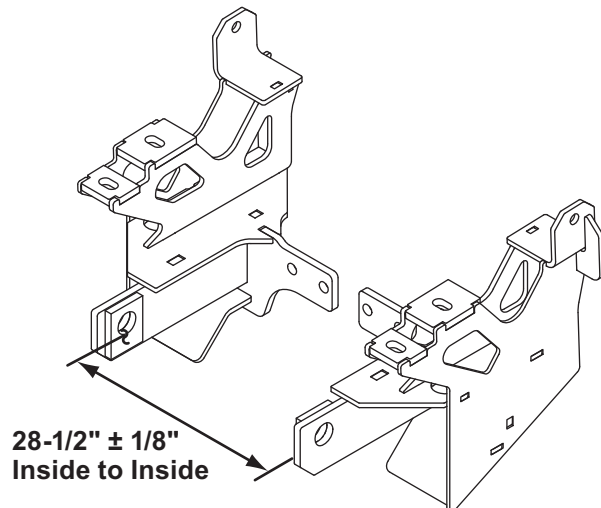
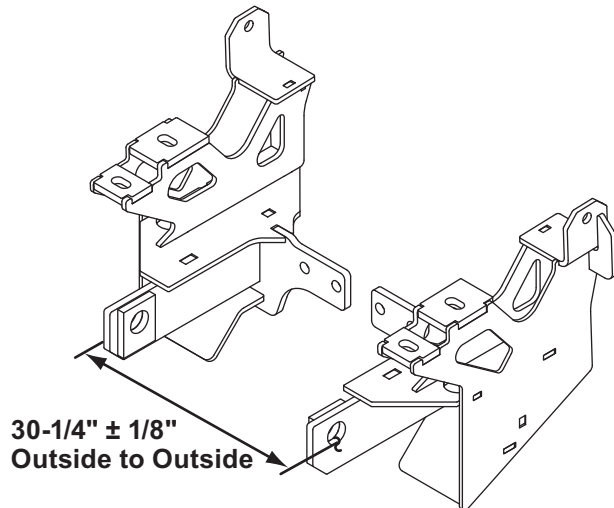

NOTE: After five to ten hours of snowplow usage, retorque all pushplate assembly fasteners.

Fisher Engineering reserves the right under its product improvement policy to change construction or design details and furnish equipment when so altered without reference to illustrations or specifications used. Fisher Engineering or the vehicle manufacturer may require or recommend optional equipment for snow removal. Do not exceed vehicle ratings with a snowplow. Fisher Engineering offers a limited warranty for all snowplows and accessories. See separately printed page for this important information. The following are registered (®) trademarks of Douglas Dynamics, L.L.C.: FISHER®, Minute Mount® 2.

Printed in U.S.A.