

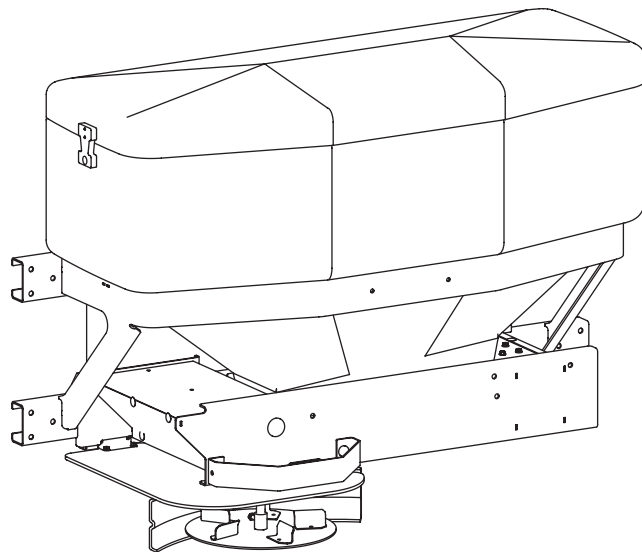

SPEED-CASTER™ 525 SPEED-CASTER™ 900 Low-Profile Tailgate Spreader

#80152, 80190

**Owner's Manual
*Original Instructions***

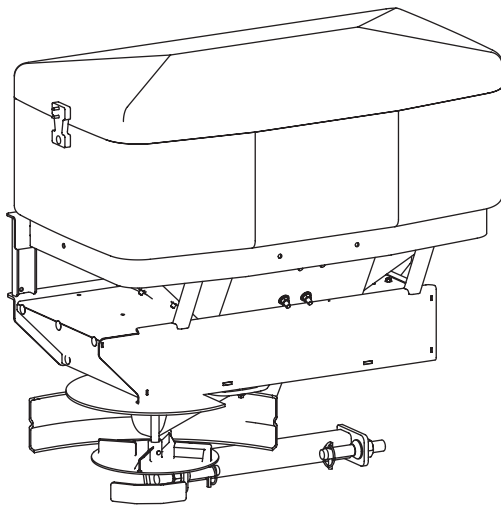

⚠ CAUTION

**Read this manual before installing or operating
the spreader.**

This manual is for FISHER® SPEED-CASTER 525 and SPEED-CASTER 900 Low-Profile Tailgate Spreaders with serial numbers beginning with 150601 through 160729.

This document supersedes all editions with an earlier date.

TABLE OF CONTENTS

INTRODUCTION	5	OPERATING THE SPREADER	13
Owner's Information Form	5	Driving and Spreading on Snow and Ice	13
SAFETY INFORMATION	6	Starting and Stopping Spreader	14
Safety Definitions	6	Controlling Material Application	15
Warning/Caution Labels	6	BLAST/Maximum Application.....	15
Serial Number Label	7	Cab Control Modes	15
Safety Precautions.....	8	Ready Mode	15
Personal Safety.....	8	ON Mode	15
Fire and Explosion	9	Error Mode	15
Cell Phones.....	9	Cab Control Codes—Table	16
Ventilation	9	Setup Procedures	18
Fuses	9	Calibrate Empty Hopper Setting.....	18
Battery Safety	9	Adjust LED Brightness Level.....	18
Noise.....	9	Auto-Reverse Feature.....	19
Vibration.....	9	Vibrator Function.....	19
LOADING	10	Controlling Flow of Material	19
Certification.....	10	Spreading Tips.....	19
Approximate Material Weights	10	MAINTENANCE	20
MOUNTING THE SPREADER	11	Lubrication	20
Model 900	11	After Each Use.....	20
Model 525	11	At the End of Each Season or after	
License Plate Installation	12	Extended Storage.....	20
		Storage	20
		Fuse Replacement.....	20
		HARNES WIRING DIAGRAM	21
		TROUBLESHOOTING GUIDE	22

INTRODUCTION

This manual has been prepared to acquaint you with the safety information, operation and maintenance of your new tailgate spreader. Please read this manual carefully and follow all recommendations. This will help ensure profitable and trouble-free operation of your hopper spreader. Keep this manual accessible. It is a handy reference in case minor service is required.

When service is necessary, bring your hopper spreader to your distributor. They know your spreader best and are interested in your complete satisfaction.

NOTE: This spreader is designed to spread snow and ice control materials only. Do not use it for purposes other than those specified in this manual.

Register your spreader online at www.fisherplows.com

OWNER'S INFORMATION

Owner's Name: _____

Date Purchased: _____

Outlet Name: _____ Phone: _____

Outlet Address: _____

Vehicle Model: _____ Year: _____

Spreader Type (Model): _____ Serial #: _____

Length: _____ Weight: _____ lb/kg: _____

SAFETY INFORMATION

SAFETY DEFINITIONS

⚠ WARNING

Indicates a potentially hazardous situation that, if not avoided, could result in death or serious personal injury.

⚠ CAUTION

Indicates a potentially hazardous situation that, if not avoided, may result in minor or moderate injury. It may also be used to alert against unsafe practices.

NOTE: Indicates a situation or action that can lead to damage to your spreader and vehicle or other property. Other useful information can also be described.

WARNING/CAUTION LABELS

Please become familiar with the Warning and Caution labels on the spreader.

NOTE: If labels are missing or cannot be read, see your sales outlet.

Spreaders With Swing Mount Option Only

⚠ WARNING

- Never swing spreader with material in hopper.
- Be sure latches are secure before operating vehicle.

D6193

⚠ WARNING

- Keep hands, feet & loose clothing away from moving parts.
- Disconnect power before servicing equipment.

D6192



⚠ WARNING

ROTATING AUGER CAN CAUSE SERIOUS INJURY OR DEATH

- Keep arms, hands, and loose clothing away from auger.
- Shut off control and unplug spreader before servicing.

D6335

⚠ WARNING

- Read owners manual before operating equipment.
- Never remove spreader with material in hopper.

D6194

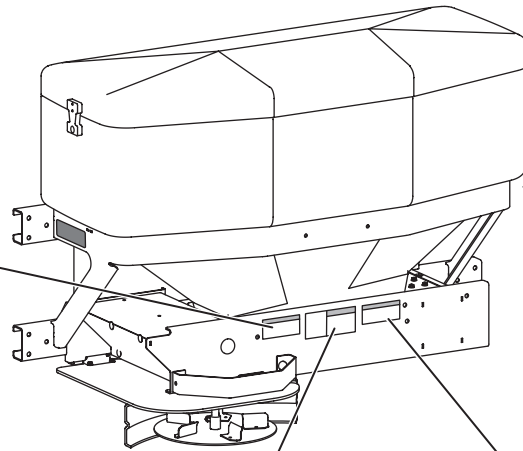

SAFETY INFORMATION

SERIAL NUMBER LABEL

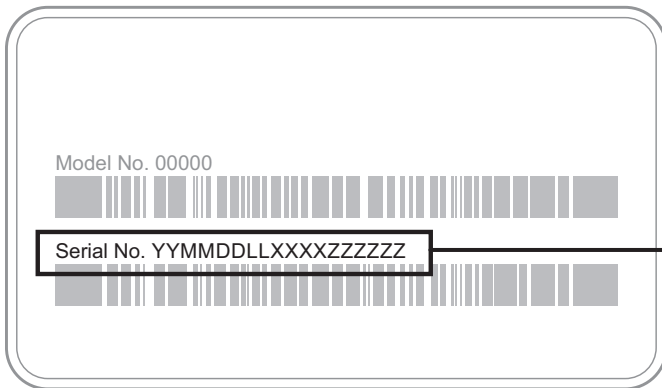
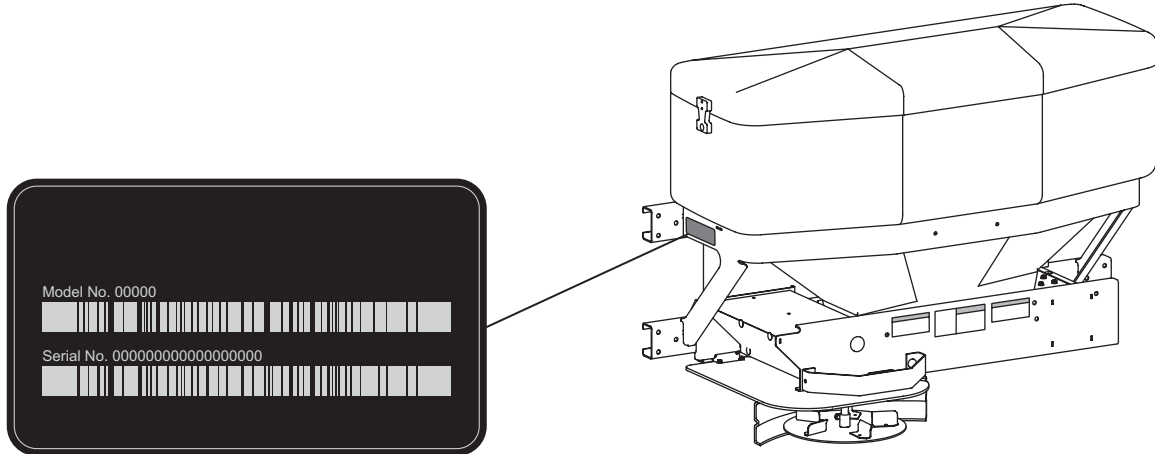

Code	Definition
YY	2-Digit Year
MM	2-Digit Month
DD	2-Digit Day
LL	2-Digit Location Code
XXXX	4-Digit Sequential Number
ZZZZZ	Assembly Part Number

SAFETY INFORMATION

SAFETY PRECAUTIONS

Improper installation and operation could cause personal injury and/or equipment and property damage. Read and understand labels and the Owner's Manual before installing, operating or making adjustments.

⚠ WARNING

- Driver to keep bystanders minimum of 25 feet away from operating spreader.
- Before working with the spreader, secure all loose-fitting clothing and unrestrained hair.
- Before operating the spreader, verify all safety guards are in place.
- Before servicing the spreader, wait for auger and spinner to stop.
- Do not climb into or ride on spreader.

⚠ WARNING



Overloading could result in an accident or damage. Do not exceed GVWR or GAWR ratings as found on the driver-side door cornerpost of the vehicle. See Loading Section to determine maximum volumes of spreading material.

⚠ WARNING

Do not install the control for this product in the deployment path of an air bag. Refer to vehicle manufacturer's manual for air bag deployment area(s).

⚠ CAUTION

During the hopper spreader installation we recommend the addition of an OSHA compliant Backup Alarm. This alarm is required for OSHA governed employers.

⚠ CAUTION

If rear directional, CHMSL light or brake stoplights are obstructed by the spreader, the lights shall be relocated, or auxiliary directional or brake stoplights shall be installed.

⚠ CAUTION

- Do not operate a spreader in need of maintenance.
- Before operating the spreader, reassemble any parts or hardware removed for cleaning or adjusting.
- Before operating the spreader, remove materials such as cleaning rags, brushes, and hand tools from the spreader.
- While operating the spreader, use auxiliary warning lights, except when prohibited by law.

⚠ CAUTION

Disconnect electric and/or hydraulic power and tag out if required before servicing or performing maintenance.

⚠ CAUTION



DO NOT leave unused material in hopper. Material can freeze or solidify, causing unit to not work properly. Empty and clean after each use.

NOTE: Lubricate grease fittings after each use. Use a good quality multipurpose grease.

PERSONAL SAFETY

- Remove ignition key and put the vehicle in park or in gear to prevent others from starting the vehicle during installation or service.
- Wear only snug-fitting clothing while working on your vehicle or spreader.
- Do not wear jewelry or a necktie, and secure long hair.
- Wear safety goggles to protect your eyes from battery acid, gasoline, dirt and dust.
- Avoid touching hot surfaces such as the engine, radiator, hoses and exhaust pipes.
- Always have a fire extinguisher rated BC handy, for flammable liquids and electrical fires.

SAFETY INFORMATION

FIRE AND EXPLOSION

⚠ WARNING

Gasoline is highly flammable and gasoline vapor is explosive. Never smoke while working on vehicle. Keep all open flames away from gasoline tank and lines. Wipe up any spilled gasoline immediately.

Be careful when using gasoline. Do not use gasoline to clean parts. Store only in approved containers away from sources of heat or flame.

CELL PHONES

A driver's first responsibility is the safe operation of the vehicle. The most important thing you can do to prevent a crash is to avoid distractions and pay attention to the road. Wait until it is safe to operate Mobile Communication Equipment such as cell phones, text messaging devices, pagers or two-way radios.

VENTILATION

⚠ WARNING

Vehicle exhaust contains lethal fumes. Breathing these fumes, even in low concentrations, can cause death. Never operate a vehicle in an enclosed area without venting exhaust to the outside.

FUSES

The spreader electrical system contains several blade-style automotive fuses. If a problem should occur and fuse replacement is necessary, the replacement fuse must be of the same type and amperage rating as the original. Installing a fuse with a higher rating can damage the system and could start a fire. Fuse Replacement, including fuse ratings and locations, is located in the Maintenance section of this Owner's Manual.

BATTERY SAFETY

⚠ CAUTION

Batteries normally produce explosive gases which can cause personal injury. Therefore, do not allow flames, sparks or lit tobacco to come near the battery. When charging or working near a battery, always cover your face and protect your eyes, and also provide ventilation.

- **Batteries contain sulfuric acid which burns skin, eyes and clothing.**
- **Disconnect the battery before removing or replacing any electrical components.**

NOISE

Airborne noise emission during use is below 70 dB(A) for the spreader operator.

VIBRATION

Operating spreader vibration does not exceed 2.5 m/s² to the hand-arm or 0.5 m/s² to the whole body.

LOADING

This Manual covers vehicles which have been recommended for carrying the spreader. Please see your local dealer for proper vehicle applications.

CERTIFICATION

⚠ WARNING

New untitled vehicle installation of a spreader requires National Highway Traffic Safety Administration altered vehicle certification labeling. Installer to verify that struck load of snow or ice control material does not exceed GVWR or GAWR rating label and complies with FMVSS.

SPREADER SPECIFICATIONS

Model	Weight	Max. Capacity
Model 525 Tailgate Spreader with Standard Mount	160 lb	5.25 ft ³
Model 900 Tailgate Spreader	180 lb	9.0 ft ³
2" Receiver Hitch Mount w/ Adapter	84 lb	—
Pivot Mount	89 lb	—
3-Point Mount	38 lb	—

APPROXIMATE MATERIAL WEIGHTS

⚠ WARNING

Overloading could result in an accident or damage. Do not exceed GVWR or GAWR as found on the driver-side cornerpost of vehicle.

⚠ WARNING

Do not overload vehicle. Use chart below to calculate weight of material. Weights of material are an average for dry materials.

⚠ CAUTION

Never use wet materials or materials with foreign debris with any of these spreaders. These units are designed to handle dry, clean, free flowing material.

⚠ CAUTION



Read and adhere to manufacturer's ice-control material package labeling including Material Safety Data Sheet requirements.

Material	Density (lb/ft ³)
Rock Salt (Dry)	80–90
Sand/Salt Mix (Dry)	95–120
A 1:1 ratio is recommended for salt/sand mix to prevent material from freezing.	

Weight of spreader and mount must be added to struck material weight to determine total spreader weight.

NOTE: If spreader and ice control material loading is in doubt, weigh vehicle for compliance with vehicle ratings.

MOUNTING THE SPREADER

⚠ CAUTION

During removal or mounting, securely grip spreader to avoid dropping.

The spreader shall be installed according to instructions supplied. Your local outlet is trained to provide this service and service your spreader with factory original parts.

MODEL 900

Mounts are sold separately for the model 900 spreader. Refer to the instructions packed with the selected mount.

MODEL 525

The model 525 spreader ships from the factory with the hitch set up in the 3-point mount position.

To switch the spreader to the truck mount position, remove the hitch, rotate it 180° as shown below, and reinstall it.

3-POINT MOUNT POSITION

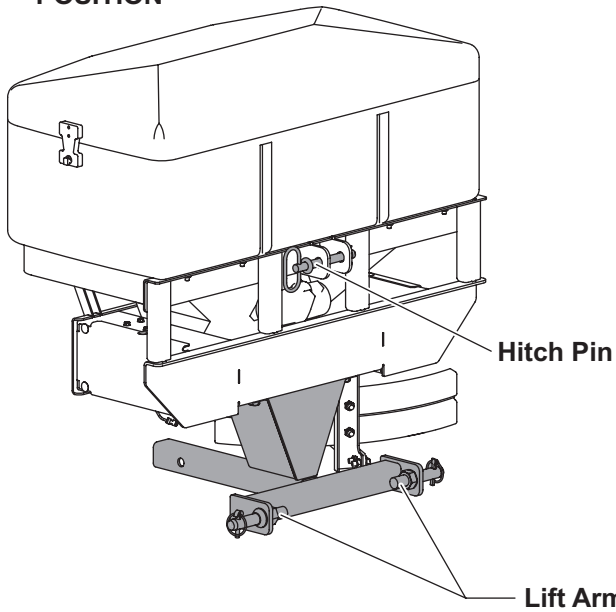

TRUCK MOUNT POSITION

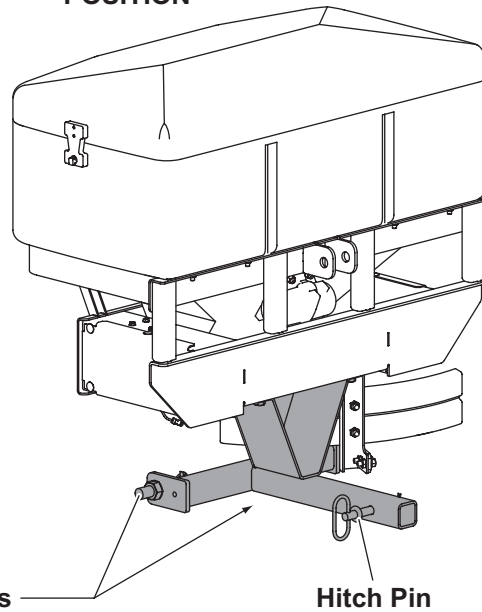

MOUNTING THE SPREADER

Always use the longer (1-1/2") cap screw and washer to attach the corner of the hitch that fits behind the tab of the material chute.

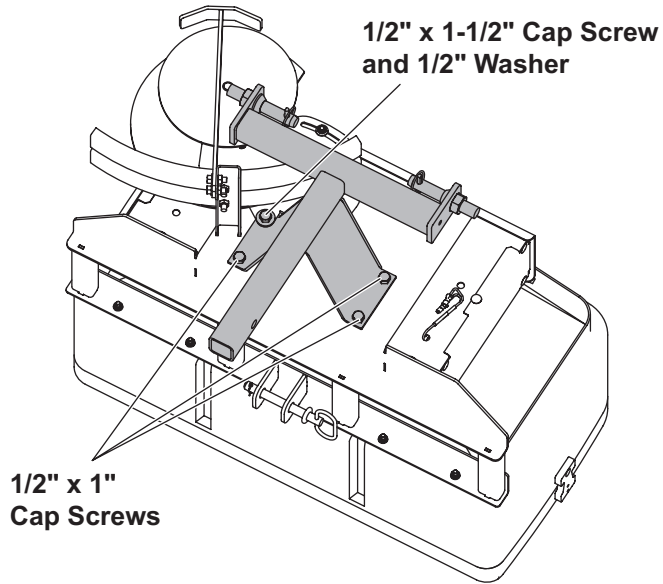

LICENSE PLATE INSTALLATION (IF REQUIRED)

Install the license plate to the mounting holes in the frame using two 1/4" x 1/2" machine screws and two 1/4" locknuts.

License Plate Mounting Holes

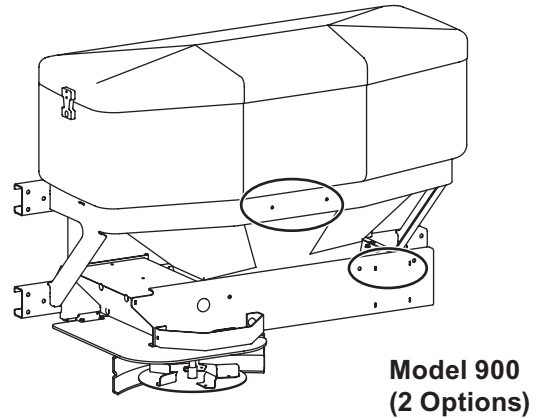
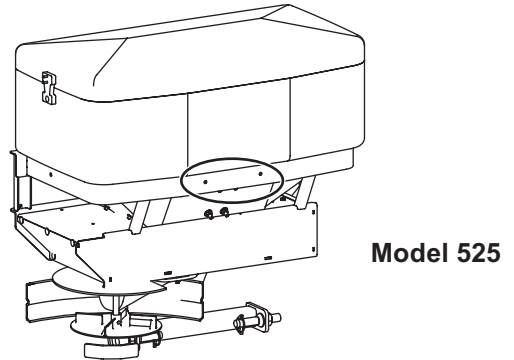

OPERATING THE SPREADER

DRIVING AND SPREADING ON SNOW AND ICE

⚠ CAUTION

Drinking and then driving or spreading is very dangerous. Your reflexes, perceptions, attentiveness and judgement can be affected by even a small amount of alcohol. You can have a serious or even fatal collision if you drive after drinking. Please do not drink then drive or spread ice-control materials.

Follow your vehicle owner's manual instructions for driving in snow and ice conditions. Remember, when you drive on snow or ice, your wheels will not get good traction. You cannot accelerate as quickly, turning is more difficult, and you will need longer braking distance. Wet and hard packed snow or ice offer the worst tire traction. It is very easy to lose control. You will have difficulty accelerating. If you do get moving, you may have poor steering and difficult braking, which can cause you to slide out of control.

Here are some tips for driving in these conditions:

- Drive defensively.
- Do not drink, then drive or spread ice-control materials.
- Spread or drive only when you have good visibility for operating a vehicle.
- If you cannot see well due to snow or icy conditions, you will need to slow down and keep more space between you and other vehicles.
- Slow down, especially on higher-speed roads. Your headlamps can light up only so much road ahead.
- If you are tired, pull off in a safe place and rest.
- The spreader's size and location reduce driver visibility to the rear of the vehicle. We recommend an OSHA compliant backup alarm for all governed employers.
- Keep your windshield and all glass on your vehicle clean to see around you.
- Dress properly for the weather. Wear layers of clothing; as you get warm, you can take off layers.

OPERATING THE SPREADER – CAB CONTROL

⚠ WARNING

Never operate equipment when under the influence of alcohol, drugs, or medications that might alter your judgment and/or reaction time.

⚠ WARNING

Never exceed 45 mph (72 km/h) when loaded spreader is attached to vehicle. Braking distances may be increased and handling characteristics may be impaired at speeds above 45 mph (72 km/h).

⚠ WARNING

Never allow children to operate or climb on equipment.

⚠ WARNING

Before starting the spreader, the driver shall verify that all bystanders are a minimum of 25 feet away from operating spreader.

STARTING AND STOPPING SPREADER

To start the spreader, press the ON/OFF button. The control backlights are illuminated when the vehicle ignition is ON. When the spreader is ON, the ON/OFF button and inner arc around each control knob will also illuminate.

To stop the spreader, press the ON/OFF button again.

The ON/OFF button also operates as an emergency stop when required.

NOTE: The truck ignition must be ON to start the spreader.

NOTE: If truck ignition is turned OFF while spreader is running, the motors will stop.

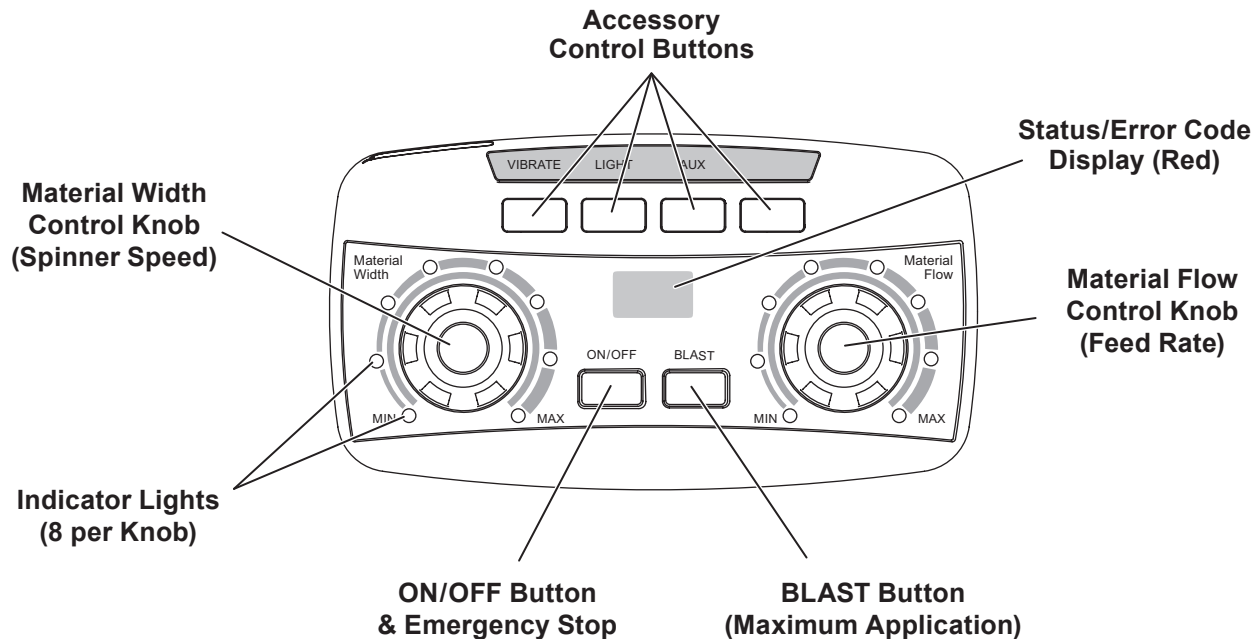

OPERATING THE SPREADER – CAB CONTROL

CONTROLLING MATERIAL APPLICATION

The material application settings can be adjusted while spreader is ON or OFF. Settings are shown by the indicator lights around the control knobs. When the spreader is OFF, a single LED will light to show the current setting. When the spreader is ON, the number of blue LEDs illuminated will increase/decrease as the knobs are turned clockwise/counterclockwise.

The auger drive will not deliver material until the ON button is pressed.

The Material Width (left) knob controls spinner speed. Turning the knob clockwise will increase the width of the application area.

The Material Flow (right) knob controls the auger drive. Turning the knob clockwise will increase the feed rate of material to the spinner.

Turning the control knobs counterclockwise will decrease the width of the application area and the feed rate of material.

BLAST/Maximum Application

1. Press and hold the BLAST button when maximum flow rate and application area are needed temporarily. The BLAST button will illuminate while depressed.
2. Release the button when maximum application settings are no longer needed.

NOTE: Spinner speed and material feed rate revert to the previous settings once the BLAST button is released.

CAB CONTROL MODES

If "1.8" appears on the display while the cab control is powering up, the control is running software v1.8. See the Lit. No. 70502, Rev. 01, supplement to this manual.

Ready Mode

Vehicle ignition is set to ACC or ON; cab control is OFF. Control has power.

The Material Width and Material Flow control knobs can be set to start-up conditions, but the spinner and drives will not operate until the control is turned ON.

Accessory lights and vibrator are operational. The BLAST function is not operational.

ON Mode

Vehicle ignition is set to ACC or ON; cab control is ON. Spinner and hopper motors will start. All cab control functions are operational. Accessory lights and vibrator are operational.

During normal spreader operation no control codes are displayed. Information or setup codes will appear when relevant. These codes will not stop spreader operation.

Error Mode

When an error condition occurs, spreader operation will shut down. A two-digit error code will flash on the display and a beep will sound. If there are multiple error codes, the codes will flash in a repeating sequence.

Refer to the Error Codes portion of the following Cab Control Codes table. Also see the Troubleshooting Guide section of this manual.

Once the error condition has been resolved, press the ON/OFF button to clear the error code(s). Press the ON/OFF button again to resume spreader operation.

The error code will reappear if the error condition has not been rectified. If the error condition persists, contact your authorized dealer.

Multiple resets within a short time frame will cause the hopper module to time out if components are overheating. The control will display an **EF** error code.

Accessory work lights and AUX can be used when an error code is in effect, and will remain in their current state. The vibrator will not function.

OPERATING THE SPREADER – CAB CONTROL

CAB CONTROL CODES

Setup Codes		
Code	Definition	Procedure
Cb	Calibrate the Empty Hopper setting.	With control in ON mode, press and hold the left control knob until the Cb code displays. Calibration cycle is automatic.*
Cc	Clear calibration data for Empty Hopper setting; clear EH code.	Press the right control knob to clear all calibration data during the calibration cycle.
LS	Set LED brightness level.	With control in Ready mode, press and hold left control knob to get LS code. Release pressure and turn left control knob to desired brightness setting. Wait for confirming SL code to display.*
SL	Confirms that LED brightness level has been reset.	

* For full instructions, see the "Setup Procedures" section.

Information Codes		
Code	Definition	Response
Ar	Auto-reverse sequence is active.	The spreader will automatically detect and attempt to clear a jam. See the "Operating the Spreader" section of this manual.
dU	Not applicable to tailgate spreaders. Possibly indicates a harness or module issue.	Contact authorized dealer.
EH	Empty hopper (beep will sound).	Check hopper for material. Recalibrate Empty Hopper setting as described above for Cb code.
Lb	Low battery. Hopper module is sensing < 10V. (Lb becomes an error code when module senses < 6V.)	Refer to the Lb row under "Error Codes" (next page).

Error Codes – Spreader Operation Stopped			
Code	Definition	Possible Cause	Suggested Solution
bb	Bad button	Button is stuck. Button was pressed while vehicle ignition was entering ACC or START mode. Possible harness issue.	Inspect control. Free up button. Do not press any spreader cab control buttons while the vehicle ignition is being engaged. Check connections and integrity of vehicle harness.
bH	Bad hopper	Possible module or control mismatch.	Replace control or module. Use only genuine service parts. Contact authorized dealer.
CE	No communication with spreader module	Loose connection. Module lost power.	Confirm that spreader and control harnesses are connected to the vehicle harness. Check fuses, power to spreader module, all connections and power studs. Check that B port is plugged into the module.
CF	Control malfunction	Control is overheating. May be a combination of faults.	Inspect connections at spreader module, hopper drive motor and spinner drive motor.

OPERATING THE SPREADER – CAB CONTROL

Error Codes – Spreader Operation Stopped – <i>continued</i>			
Code	Definition	Possible Cause	Suggested Solution
CP	Not applicable to tailgate spreaders. See suggested solution.	Not applicable to tailgate spreaders.	Reset the control by pressing the ON/OFF button. If CP code continues to display, contact authorized dealer.
Ct	Control is hot.	Cab temperature is too high. Control overheated.	Turn off spreader and allow control to cool off.
EF	Excessive drive faults	Too many HO and/or SO error codes; hopper module overheating.	Control times out for 60 seconds. Ensure that auger and/or spinner are not jammed.
HO	Hopper overload – software trip	Drive system has high current. Material is jammed.	Inspect auger; clear material jam.
HO.	Hopper overload – hardware trip	Auger is damaged.	
HP	Hopper power issue. No motor present.	Hopper drive motor is not connected. Possible motor defect.	Check connections to the auger drive motor (P—FEED and FEED—N posts on the module and studs on the motor). Replace the motor.
Lb	Low battery. Hopper module is sensing $\leq 6V$.	Bad connection or low battery. Snowplow or other vehicle power use may be driving down voltage.	Voltage is measured at the hopper module, so Lb code may indicate cable voltage loss. Check battery, alternator and connections.
nC	No connection	Spreader not connected to vehicle harness.	Connect vehicle and spreader harness. Check vehicle harness fuse. Inspect spreader and vehicle harnesses. Check module.
OH	Overheating	Spreader module is too hot.	Allow a cool-off period—60 seconds or longer. Check for loose harness connections. Check accessory connections. Check integrity of accessory wiring and harness. Clear jammed material. Contact authorized dealer.
OH.	Overheating module – microprocessor	Spreader module malfunction. Accessories wiring/function problem. Drive motor overload.	
rS	Reset of spreader module	Power loss to module detected on startup.	Reset the control by pressing the ON/OFF button. Check vehicle harness and battery connection.
SO	Spinner drive overload – software trip	Material jammed in chute/spinner area.	Inspect spinner and spinner drive components for alignment and condition. Check for damage to bearings, shafts and sprockets. Adjust and replace parts as required.
SO.	Spinner drive overload – hardware trip	Spinner shaft is damaged.	
SP	Spinner power issue. No motor present.	Spinner drive motor is not connected. Possible motor defect.	Check connections to the motor (SPIN and GND posts on the module). Replace the motor.

OPERATING THE SPREADER – CAB CONTROL

SETUP PROCEDURES

Calibrate the Empty Hopper Setting (*Cb* and *EH* Codes)

Calibrating the empty hopper setting enables the cab control to alert the operator when the hopper is empty.

Recalibrate the empty hopper setting at the start of each ice-control season.

1. Ensure that the hopper is empty before beginning the calibration.
2. Turn the vehicle ignition to ACC or ON. Press the ON/OFF button on the cab control to turn the control ON.
3. Press and hold the Material Width (left) knob for approximately 10 seconds until the **Cb** code displays.
4. The calibration cycle will begin. The blue LEDs around the Material Flow (right) knob will illuminate in succession until all 8 are lit.
5. When the automatic calibration cycle is complete, the control will automatically revert to the previous material application settings.

If the control is turned OFF or loses power during the calibration cycle, the calibration data will be lost. Make sure the control is ON and restart the calibration process at Step 3.

Once the empty hopper setting has been calibrated, the **EH** code will flash on the display and a beep will sound whenever the hopper is empty. The **EH** code is informational only and will not stop spreader operation.

Clearing Empty Hopper Calibration Data (*Cc* Code)

The empty hopper calibration may be cleared, if desired. The control will no longer display the **EH** status code when the hopper is empty.

Start the calibration cycle as described above. At Step 4, press the Material Flow (right) knob during the calibration cycle to clear *all* calibration data. The **Cc** (Clear Calibration) code will display and the control will exit **Cc** mode automatically.

Adjust LED Brightness Level (*LS* and *SL* Codes)

The brightness setting of the cab control lights can be adjusted from 1 to 16. The factory default setting is 8.

1. Turn the vehicle ignition to ACC or ON. If necessary, press the cab control ON/OFF button to turn the control OFF.
2. Press and hold the Material Width (left) knob for approximately 3 seconds until the **LS** code is displayed.
3. Release the knob and turn it clockwise or counterclockwise to increase/decrease the brightness level. The light level number will show in the status display.
4. After selecting the desired brightness level, wait a few seconds for the **SL** confirmation code to display.

NOTE: A brightness level setting of 12 or higher is recommended for daylight conditions.

OPERATING THE SPREADER

AUTO-REVERSE (Ar) FEATURE

If "1.8" appears on the cab control display when the control is powering up, see the *Auto-Reverse Feature instructions* in Lit. No. 70502, Rev. 01.

The spreader is programmed to automatically sense and clear material jams.

The **Ar** sequence will begin automatically, and consist of a series of reverse-then-forward movements of the auger.

The **Ar** sequence will make up to five attempts to clear the jam. If the jam is cleared, the auger will automatically return to normal operation at the previous control settings.

If the jam remains after the auto-reverse cycle is exhausted, the control will indicate the **HO** error code (Hopper Overload), and shutdown the spreader.

⚠ CAUTION

Disconnect electric power and tag out if required before servicing or performing maintenance.

If the **HO** error code is displayed, then the operator must extract the material that is causing the problem. Follow all warning directions when clearing jams.

VIBRATOR FUNCTION

A heavy-duty vibrator is standard equipment on the model 525 and 900 spreaders. Turn the vibrator ON as needed to keep dense material flowing and prevent bridging of material in the hopper.

CONTROLLING FLOW OF MATERIAL

The factory-installed material baffle in the spreader stops fine materials from free flowing. When dense or damp material is being spread, or when more flow is desired, remove the material baffle. However, it is recommended that the baffle remain in place when spreading bulk salt.

The inverted vee in the model 900 spreader should not be removed except when servicing the spreader.

The Material Control Tube optional accessory prevents leaking issues when handling fine pellet and flake materials.

SPREADING TIPS

- Spread ice melters with the storm to prevent unmanageable levels of ice.
- Never exceed 10 mph (16 km/h) when spreading.
- For a wider pass, increase spinner speed.
- For a heavier pass, drive slower or increase auger speed.
- Never operate spreader near pedestrians.
- Calculate spread pattern when near vegetation.

NOTE: The spinner motor is not designed for continuous duty. Allow the motor to cool between long cycle times.

MAINTENANCE

⚠ WARNING

Never remove the spreader with material in the hopper.

⚠ CAUTION

Disconnect electric power at spreader electrical wiring harness connection and tag out if required before servicing or performing maintenance.

⚠ CAUTION

- When replacing parts use only original manufacturer's parts. Failure to do so will void warranty.
- The control is a solid-state electronic unit and is not serviceable. Any attempt to service will void warranty.
- There are no serviceable parts in the motor/transmission assembly. Any attempt to service will void warranty.
- When pressure washing motor enclosure area, stay at least 36" away from motor enclosures.

LUBRICATION

To keep your spreader running smoothly, observe the following recommendations:

- Lubricate bearings after every 20 hours of use.
- Apply a small amount of light oil to latches as needed.
- For model 900 spreader installations using the pivot mount, keep the pivot assembly well greased to prevent corrosion.

AFTER EACH USE

⚠ CAUTION



DO NOT leave unused material in hopper. Material can freeze or solidify, causing unit to not work properly. Empty and clean after each use.

- Wash out the hopper and rinse off all external surfaces.
- Apply dielectric grease on all electrical connections to prevent corrosion.

AT THE END OF EACH SEASON OR AFTER EXTENDED STORAGE

- Wash out the hopper and rinse off all external surfaces.
- Apply dielectric grease on all electrical connections to prevent corrosion.
- Lubricate all grease fittings with good quality multipurpose grease.
- Oil or paint all bare metal surfaces.
- If motor cover is removed for any reason, use silicone sealant to ensure weather proofing of enclosure.

STORAGE

Unplug the cab control from the control harness at the end of the season, or when the spreader is removed from the vehicle. Store the spreader and cab control in a clean, dry location, away from direct sunlight.

FUSE REPLACEMENT

See the Harness Wiring Diagram on the following page for fuse ratings and locations.

If a problem should occur and fuse replacement is necessary, the replacement fuse must be of the same type and amperage rating as the original. Installing a fuse with a higher rating can damage the system and could start a fire.

HARNESS WIRING DIAGRAM

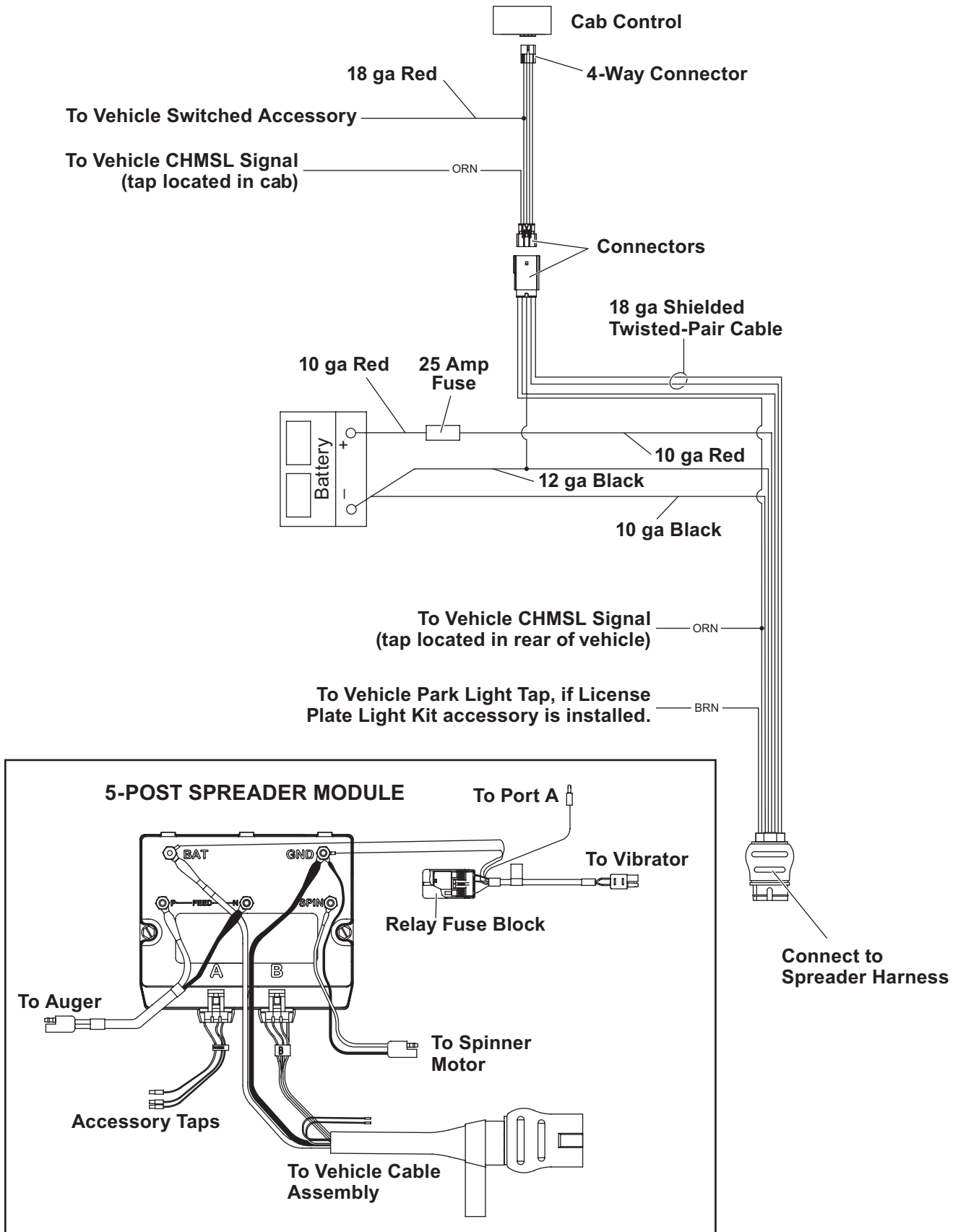

TROUBLESHOOTING GUIDE

Please see your distributor for service. The troubleshooting reference table below may guide you in diagnosing the issue.

For a reference table of the cab control error codes, see the "Operating the Spreader – Cab Control" section of this manual.

Before servicing the spreader:

- Review all safety information.
- Confirm that all electrical connections are tight and clean.
- Confirm that nothing is jammed in the hopper.

Problem	Possible Cause	Suggested Solution
No power to cab control. Ignition and control switches ON; control knob indicator lights not illuminated.	1. Control connector plug is loose.	1. Check plug connection at cab control.
	2. Switched accessory connection is poor, or faulty battery.	2a. Check for low battery. 2b. Check switched accessory connection.
	3. Blown fuse.	3. Replace 25 A spreader vehicle battery cable fuse.
	4. Vehicle control harness is damaged.	4. Repair or replace damaged wires or harness as required.
Cab control shuts down.	Unplug the spreader harness and tag out, if required, before performing any of the following repairs.	
	1. Cross-reference displayed error code with list on page 17.	1. See suggested solution on page 17. 1b. Reset the control by pressing the ON/OFF button.
	2. Poor electrical conditions.	2a. Clean or replace connectors. 2b. Apply dielectric grease.
	3. Electrical short.	3. Check electrical connections.
Turning control knobs does not change motor speed. Control is powered ON.	Unplug the spreader harness and tag out, if required, before performing any of the following repairs.	
	1. Malfunctioning cab control.	1. Replace cab control.
	2. Malfunctioning motor(s).	2. Replace motor(s).
	3. Malfunctioning spreader module.	3. Replace spreader module.
Spreader does not operate.	Unplug the spreader harness and tag out, if required, before performing any of the following repairs.	
	1. Wire harness is damaged or has an open circuit between cab control and spreader.	1a. Check plug connections at cab control and spreader. 1b. Check wire connections at vehicle battery and 25 A fuse. 1c. Check motor connections.
	2. Overloaded condition has triggered a time-out, or damaged motors or module.	2a. Wait 60 seconds for time-out to expire. 2b. Check motors. Repair or replace. 2c. Replace module.

TROUBLESHOOTING GUIDE

Problem	Possible Cause	Suggested Solution
Motor does not run.	Unplug the spreader harness and tag out, if required, before performing any of the following repairs.	
	1. Electrical connections are loose.	1. Open access cover and check motor, harness and module connections.
	2. Blown fuse.	2. Replace 25 A fuse.
	3. Motor seizes.	3. Replace motor.
Material does not flow.	Unplug the spreader harness and tag out, if required, before performing any of the following repairs.	
	1. Obstruction in hopper.	1. Clear obstruction.
	2. Material bridged.	2. Clear the bridged material.
	3. Auger loose on shaft.	3. Align auger with flat machined area on shaft and tighten locking bolt on side of auger.
	4. Auger runs backward.	4a. Check the wire connections at the "P—FEED—N" posts on the spreader module. Auger harness RED to P—FEED; auger harness BLACK to FEED—N. 4b. Check that auger motor harness is correct part number for spreader model.
	5. Material is wet.	5. Replace with dry material.
	6. Material is coarse or frozen.	6. Replace material.
	7. Spinner does not turn.	7. Check connection inside motor enclosure.
Material free flows.	1. Incorrect baffle length.	1. Install correct baffle.
	2. Baffle does not touch hopper on 3 sides.	2. Reposition baffle.
Vibrator does not work.	1. Electrical connections are loose.	1a. Check the vibrator to harness connection. 1b. Check vibrator harness to module connections (BAT, GND and blue bullet connector).
	2. Blown fuse.	2. Open access cover to replace 25 A fuse in the fuse holder on the vibrator harness.
	3. Vibrator failure.	3. Replace vibrator.



Fisher Engineering
50 Gordon Drive
Rockland, ME 04841-2139
www.fisherplows.com

A DIVISION OF FISHER, LLC

Copyright © 2016 Douglas Dynamics, LLC. All rights reserved. This material may not be reproduced or copied, in whole or in part, in any printed, mechanical, electronic, film or other distribution and storage media, without the written consent of Fisher Engineering. Authorization to photocopy items for internal or personal use by Fisher Engineering outlets or spreader owner is granted.

Fisher Engineering reserves the right under its product improvement policy to change construction or design details and furnish equipment when so altered without reference to illustrations or specifications used. Fisher Engineering or the vehicle manufacturer may require or recommend optional equipment for spreaders. Do not exceed vehicle ratings with a spreader. Fisher Engineering offers a limited warranty for all spreaders and accessories. See separately printed page for this important information. The following are registered (®) or unregistered (™) trademarks of Douglas Dynamics, LLC: SPEED-CASTER™, FISHER®.

Printed in U.S.A.