



44685-1, 44685-2, 44695-1, 44695-2, 44775-1, 44775-2, 44785-1
44785-2, 44795-1, 44795-2, 85000, 85000-1
Fisher Engineering 85000-3, 85500, 85500-1, 85500-3

50 Gordon Drive, Rockland, Maine 04841-2139 • www.fisherplows.com

January 1, 2021
Lit. No. 49595, Rev. 07



XtremeV™ Snowplow

Installation Instructions

▲ CAUTION

Read this document before installing the snowplow.

▲ CAUTION

See your FISHER® outlet/website for specific vehicle application recommendations before installation. The eMatch selection system has specific vehicle and snowplow requirements.

SAFETY DEFINITIONS

WARNING

Indicates a potentially hazardous situation that, if not avoided, could result in death or serious personal injury.

CAUTION

Indicates a potentially hazardous situation that, if not avoided, may result in minor or moderate injury. It may also be used to alert against unsafe practices.







NOTE: Indicates a situation or action that can lead to damage to your snowplow and vehicle or other property. Other useful information can also be described.

WARNING/CAUTION AND INSTRUCTION LABELS

Become familiar with and inform users about the warning labels on the back of the blade and the instruction label on the headgear.

NOTE: If labels are missing or cannot be read, see your sales outlet.

Warning/Caution Label

 WARNING	
	Blade could drop unexpectedly, crushing or trapping limbs. Lower blade when vehicle is parked.
	Overloading could negatively affect vehicle handling. To avoid serious injury or death, do not exceed GVWR or GAWR including blade and ballast.
 CAUTION	
	Read Owner's Manual before operating or servicing snowplow.
	Transport speed should not exceed 45 mph (72 km/h). Further reduce speed under adverse travel conditions.
	Plowing speed should not exceed 10 mph (16 km/h).
See your sales outlet/website for specific vehicle application recommendations.	
WWW.	

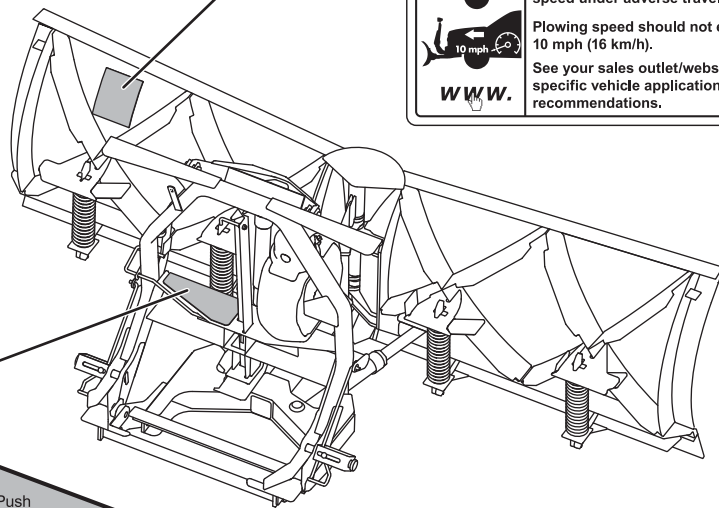

Instruction Label

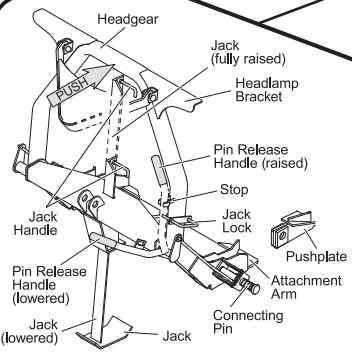

1. Push **Pin Release Handle** down to pull out **Connecting Pins**.
2. Drive vehicle slowly to engage **Pushplates** into **Attachment Arms**.
3. Stand in front of blade. Fully raise **Pin Release Handle** to release **Connecting Pins**.
4. Push **Headgear** toward vehicle to allow **Connecting Pins** to fully engage **Pushplates**. If unable to push **Headgear** from in front of blade, stand in front of **Headgear** on driver side and push **Headlamp Bracket**.
5. Pull out **Jack Lock**. Push **Pin Release Handle** into **Stop**.
6. While holding **Jack Lock** out, use **Jack Handle** to raise **Jack** fully. Release **Jack Lock**.
7. Attach all electrical connectors.

ATTACH
DETACH

US patents 6,408,549; 6,526,677; 6,711,837; 6,928,757; 6,944,976; 7,400,058; 7,430,821; 7,681,334; 7,737,576; 7,797,859; 9,200,418; 9,822,563; CAN patents 2,354,257; 2,356,036; 2,632,102; 2,639,052, and other patents pending.

Read *Owner's Manual* for complete instructions.

1. Place control in Lower/Float to put blade down.
2. Pull and hold **Jack Lock** out. **Jack** will drop to ground. Then pull **Pin Release Handle** away from **Stop** and **Jack Lock**. Release **Jack Lock**. Verify that **Jack** is locked by trying to lift **Jack**.
3. Stand in front of blade. While pushing **Headgear** toward vehicle with left hand, push **Pin Release Handle** down to disengage **Connecting Pins**. Make sure **Connecting Pins** are fully retracted. If unable to push **Headgear** from in front of blade, stand in front of **Headgear** on driver side and push **Headlamp Bracket**.
4. Detach all electrical connectors.

SAFETY PRECAUTIONS

Improper installation and operation could cause personal injury and/or equipment and property damage. Read and understand labels and the Owner's Manual before installing, operating, or making adjustments.

⚠ WARNING

Lower blade when vehicle is parked. Temperature changes could change hydraulic pressure, causing the blade to drop unexpectedly or damaging hydraulic components. Failure to do this could result in serious personal injury.

⚠ WARNING

The driver shall keep bystanders clear of the blade when it is being raised, lowered, or angled. Do not stand between the vehicle and the blade or within 8 feet of a moving blade. A moving or falling blade could cause personal injury.

⚠ WARNING

Keep hands and feet clear of the blade and T-frame when mounting or removing the snowplow. Moving or falling assemblies could cause personal injury.

⚠ WARNING

Do not exceed GVWR or GAWR including blade and ballast. The rating label is found on driver-side vehicle door cornerpost.

⚠ WARNING

To prevent accidental movement of the blade, always turn the control OFF whenever the snowplow is not in use. The power indicator light will turn OFF.

⚠ WARNING

Remove blade assembly before placing vehicle on hoist.

⚠ CAUTION

Refer to the current eMatch selection system for minimum vehicle recommendations and ballast requirements.

HYDRAULIC SAFETY

⚠ WARNING

Hydraulic fluid under pressure can cause skin injection injury. If you are injured by hydraulic fluid, get medical attention immediately.

- Always inspect hydraulic components and hoses before using. Replace any damaged or worn parts immediately.
- If you suspect a hose leak, DO NOT use your hand to locate it. Use a piece of cardboard or wood.

FUSES

The FISHER® electrical and hydraulic systems contain several automotive-style fuses. If a problem should occur and fuse replacement is necessary, the replacement fuse must be of the same type and amperage rating as the original. Installing a fuse with a higher rating can damage the system and could start a fire. Fuse Replacement, including fuse ratings and locations, is located in the Maintenance section of the Owner's Manual.

PERSONAL SAFETY

- Remove the ignition key and put the vehicle in PARK or in gear to prevent others from starting the vehicle during installation or service.
- Wear only snug-fitting clothing while working on your vehicle or snowplow.
- Do not wear jewelry or a necktie, and secure long hair.
- Wear safety goggles to protect your eyes from battery acid, gasoline, dirt, and dust.
- Avoid touching hot surfaces such as the engine, radiator, hoses, and exhaust pipes.
- Always have a fire extinguisher rated BC handy, for flammable liquids and electrical fires.

FIRE AND EXPLOSION

WARNING

Gasoline is highly flammable and gasoline vapor is explosive. Never smoke while working on vehicle. Keep all open flames away from gasoline tank and lines. Wipe up any spilled gasoline immediately.

Be careful when using gasoline. Do not use gasoline to clean parts. Store only in approved containers away from sources of heat or flame.

CELL PHONES

A driver's first responsibility is the safe operation of the vehicle. The most important thing you can do to prevent a crash is to avoid distractions and pay attention to the road. Wait until it is safe to operate mobile communication equipment such as cell phones, text messaging devices, pagers, or two-way radios.

VENTILATION

WARNING

Vehicle exhaust contains lethal fumes. Breathing these fumes, even in low concentrations, can cause death. Never operate a vehicle in an enclosed area without venting exhaust to the outside.

BATTERY SAFETY

CAUTION

Batteries normally produce explosive gases, which can cause personal injury. Therefore, do not allow flames, sparks, or lit tobacco to come near the battery. When charging or working near a battery, always cover your face and protect your eyes, and also provide ventilation.

- Batteries contain sulfuric acid, which burns skin, eyes, and clothing.
- Disconnect the battery before removing or replacing any electrical components.

NOISE

Airborne noise emission during use is below 70 dB(A) for the snowplow operator.









VIBRATION

Operating snowplow vibration does not exceed 2.5 m/s² to the hand-arm or 0.5 m/s² to the whole body.

TORQUE CHART

CAUTION

Read instructions before assembling. Fasteners should be finger tight until instructed to tighten according to the torque chart. Use standard methods and practices when attaching snowplow, including proper personal protective safety equipment.

Recommended Fastener Torque Chart					
Inch Fasteners Grade 5 and Grade 8					
Size	Torque (ft-lb)		Size	Torque (ft-lb)	
	 Grade 5	 Grade 8		 Grade 5	 Grade 8
1/4-20	8.4	11.9	9/16-12	109	154
1/4-28	9.7	13.7	9/16-18	121	171
5/16-18	17.4	24.6	5/8-11	150	212
5/16-24	19.2	27.3	5/8-18	170	240
3/8-16	30.8	43.6	3/4-10	269	376
3/8-24	35.0	49.4	3/4-16	297	420
7/16-14	49.4	69.8	7/8-9	429	606
7/16-20	55.2	77.9	7/8-14	474	669
1/2-13	75.3	106.4	1-8	644	909
1/2-20	85.0	120.0	1-12	704	995
Metric Fasteners Class 8.8 and 10.9					
Size	Torque (ft-lb)		Size	Torque (ft-lb)	
	 Class 8.8	 Class 10.9		 Class 8.8	 Class 10.9
M6 x 1.00	7.7	11.1	M20 x 2.50	325	450
M8 x 1.25	19.5	26.9	M22 x 2.50	428	613
M10 x 1.50	38.5	53.3	M24 x 3.00	562	778
M12 x 1.75	67	93	M27 x 3.00	796	1139
M14 x 2.00	107	148	M30 x 3.50	1117	1545
M16 x 2.00	167	231	M33 x 3.50	1468	2101
M18 x 2.50	222	318	M36 x 4.00	1952	2701
These torque values apply to fasteners except those noted in the instructions.					

HEADGEAR TO T-FRAME ASSEMBLY

NOTE: For easier assembly and installation, vehicle and all snowplow components should be on a smooth, level, hard surface, such as concrete.

1. With the vehicle parked on a solid, level surface, measure the distance from the center of the connecting pin hole to the ground. Using this measurement, refer to the hole selection table below to determine which rear hole should be used to attach the headgear to the push assembly.

Pushplate Height (hole center to ground)	Rear Hole
17" to 19"	Top
15" to 17" (typical)	Middle
13" to 15"	Bottom

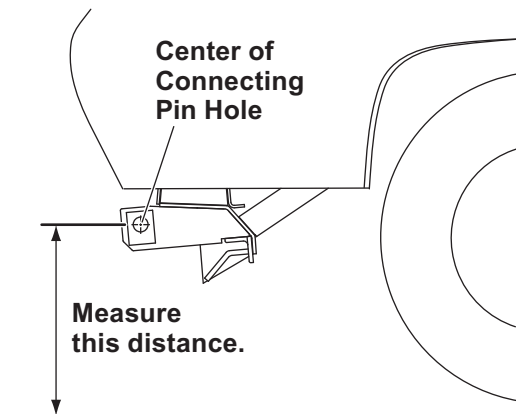

2. If the vehicle is unavailable, use the middle holes and reposition the headgear later, if necessary.
3. Set aside the pivot pin, parts bags, and blade guides. The vehicle electrical harnesses and Owner's Manual packet are in the bag with the headlamp box.
4. Remove the hardware and blocking securing the T-frame to the pallet.

5. Remove the strapping securing the headgear to the T-frame.
6. While supporting the headgear, remove and retain the four pins and discard the shipping brackets.
7. Position the headgear so that the holes in the headgear are aligned with the previously selected holes in the push assembly. Attach the push assembly to the headgear assembly with two step pins, 1" flat washers, and 1/4" x 1-1/2" cotter pins. Insert the step pins from the outside of the headgear. Insert a 1" flat washer between the headgear and the outside of the push assembly on both sides.

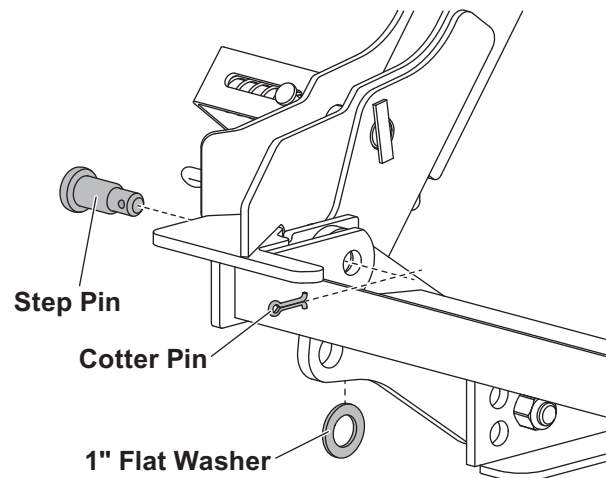

8. If the lowest set of holes in the push assembly are used, the stacking stops attached to the headgear can be removed and replaced with the shorter set of stacking stops that are attached to the pallet.
9. Verification of proper T-frame position will be made during final adjustments at the end of these instructions.

T-FRAME TO BLADE ASSEMBLY

1. Align the hinges of each wing. Position the T-frame assembly between the blade wings so that the holes in the T-frame are aligned with the holes in the wing hinges.
2. Insert the pivot pin from top to bottom through all the hinges as shown.

1" x 4-3/4" Clevis Pins

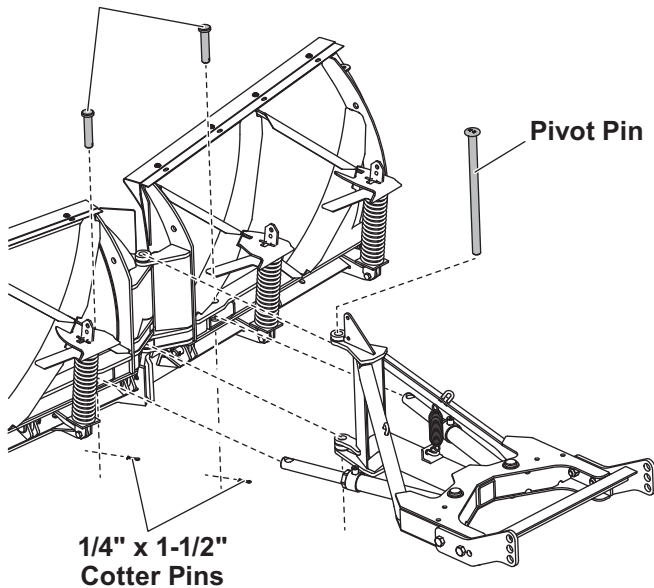

3. With the snowplow in normal operating position, lower the jack to support the headgear. Release the jack lock to hold the jack in position.

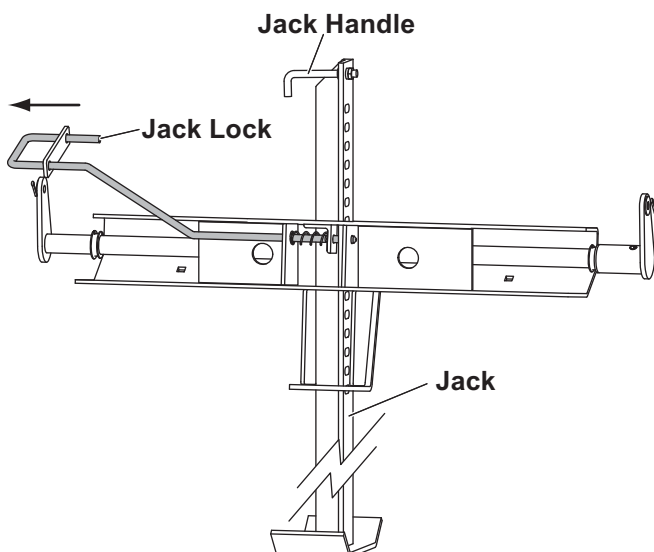

4. Remove the protective packaging from the angle rams.
5. Align the holes in the rod end of the angle ram with the corresponding holes on the back of the blade.
6. Install a 1" x 4-3/4" clevis pin from the top down to attach each rod. Secure the clevis pins with 1/4" x 1-1/2" cotter pins.
7. Install the center snow deflector using two 3/8" x 1-1/4" cap screws and 3/8" locknuts.

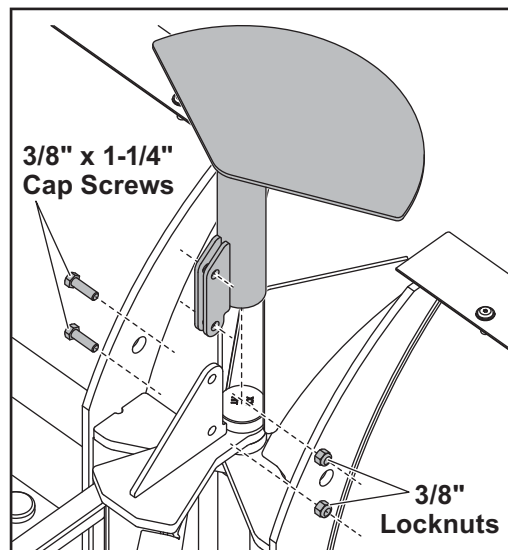

8. Install the blade guides.

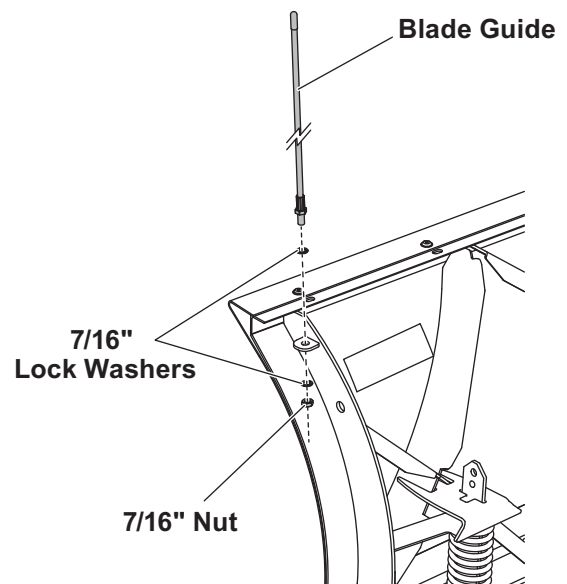

HEADLAMPS

⚠ WARNING

Your vehicle must be equipped with snowplow headlamps and directional lights.

Headlamps, hardware, and instructions are found in the headlamp box.

1. Install the vehicle wiring according to the instructions provided.
2. With the driver- and passenger-side headlamps on the correct sides, set each headlamp and swivel into place on the headgear light bar.
3. Secure the headlamps with the correct hardware for the application as shown below. Inner and outer posts require different hardware. On LED headlamps, a rubber washer must be installed under the slotted holes. Hand tighten fasteners.
4. Connect the headlamp wires to the headlamps.
5. Aim the headlamps according to the Snowplow Headlamp Beam Aiming Instructions (Lit. No. 27769). For LED headlamps, tighten the fasteners to 22 ft-lb (30 N·m). For halogen headlamps, tighten the fasteners to 50 ft-lb (68 N·m).

6. Secure the snowplow harnesses and wires to the headgear with cable ties as shown.

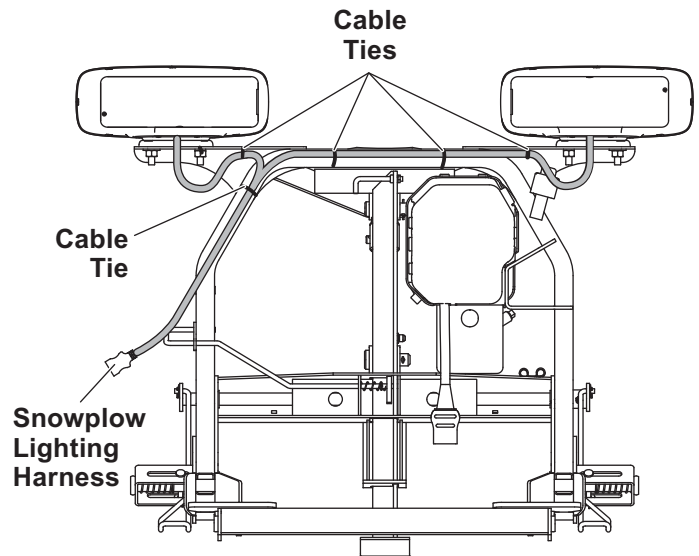

Halogen Headlamps

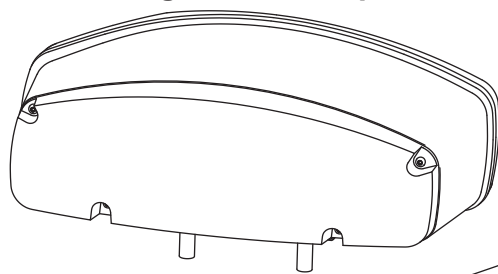

LED Headlamps

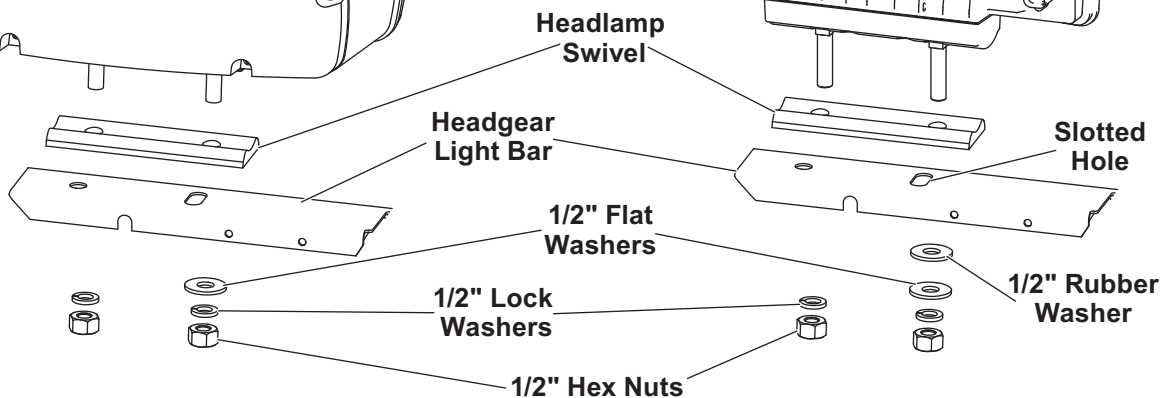
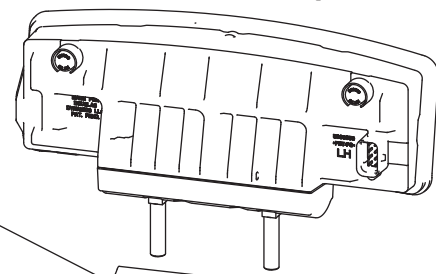

HYDRAULIC UNIT

⚠ WARNING

Keep 8' clear of the blade when it is being raised, lowered, or angled. Do not stand between the vehicle and blade or directly in front of the blade. If the blade hits or drops on you, you could be seriously injured.

The XtremeV™ snowplow hydraulic unit comes from the factory pre-assembled, partially filled, and fully tested.

1. Attach the snowplow to the vehicle according to the instructions on the headgear.
2. Remove and discard the factory-installed pipe plug from the top of the reservoir and install the breather.

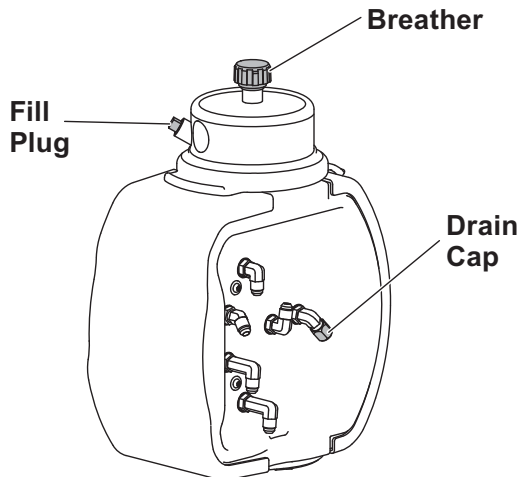

⚠ WARNING

To prevent accidental movement of the blade, always turn the control OFF whenever the snowplow is not in use. The power indicator light will turn OFF.

3. Turn the control ON and completely extend and retract the driver-side wing several times. Repeat for the passenger-side wing. With both wings fully retracted, raise and lower the snowplow several times. Activate the control FLOAT function and manually collapse the lift ram all the way. Turn the control OFF.

⚠ CAUTION

Do not mix different types of hydraulic fluid. Some fluids are not compatible and may cause performance problems and product damage.

4. Remove the fill plug and check the fluid level. With the snowplow wings and lift ram fully retracted, the fluid level should reach the fill hole. If additional fluid is needed, fill the reservoir with FISHER® EZ Flow Hydraulic Fluid rated to -40°F (-40°C), or other fluid conforming to Military Specification MIL-H-5606 A, such as Mobil Aero HFA or Shell AeroShell® Fluid 4.

NOTE: Remove fill plug slowly to relieve any pressure in reservoir.

NOTE: Add fluid only when all rams are retracted.

5. Replace and tighten the fill plug.

FLUID CAPACITY

- Insta-Act® Unit Reservoir 1-3/4 quarts
- Insta-Act System Total 2-3/8 to 2-3/4 quarts

BLADE DROP SPEED ADJUSTMENT

⚠ WARNING

Keep 8' clear of the blade when it is being raised, lowered, or angled. Do not stand between the vehicle and blade or directly in front of the blade. If the blade hits or drops on you, you could be seriously injured.

The quill in the top of the valve manifold adjusts the blade drop speed.

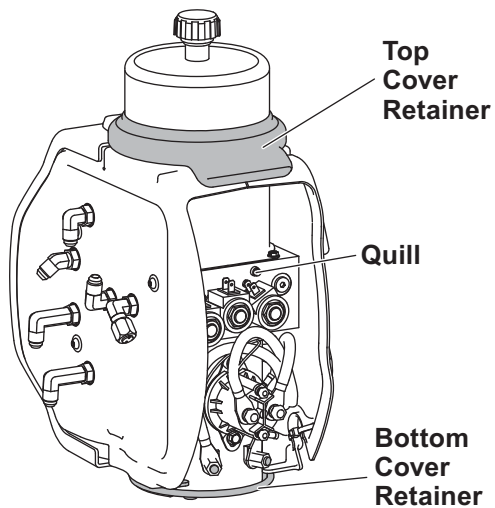

1. Lower the blade to the ground before making adjustments.
2. To access the quill on the hydraulic unit, raise the top cover retainer, remove the bottom cover retainer, and remove the rear cover.
3. Turn the quill IN (clockwise) to decrease drop speed. Turn the quill OUT (counterclockwise) to increase drop speed.
4. Stand 8' clear of the blade when checking adjustment.
5. Replace the cover and reinstall the top and bottom cover retainers.

FINAL ADJUSTMENTS

⚠ WARNING

Keep 8' clear of the blade when it is being raised, lowered, or angled. Do not stand between the vehicle and blade or directly in front of the blade. If the blade hits or drops on you, you could be seriously injured.

Leveling the T-Frame

1. With the snowplow attached to the properly ballasted vehicle, and blade lowered to ground, the T-frame should be parallel with the ground. If not, place the snowplow in the scoop position.

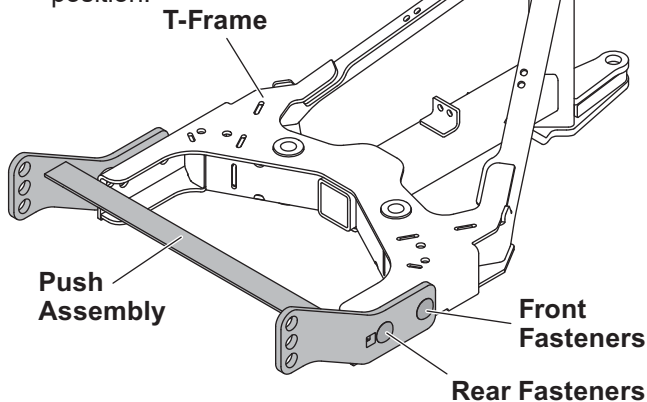

2. Loosen the front fasteners for the push assembly to T-frame connection, but do not remove them. Next, remove the rear fasteners from the push beam to T-frame connection. Level the T-frame.
3. Select the hole in the rear of the T-frame that is aligned closest to the rear holes in the push assembly. Reassemble the previously removed fasteners into the rear holes and tighten all fasteners according to the torque chart.

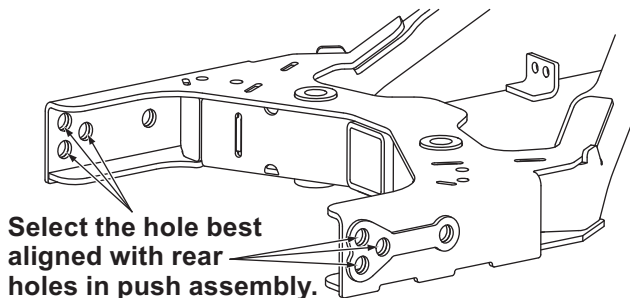

Lift Chain

1. Adjust the length of the lift chain on the driver's side (with attached spring) so that the T-frame hits the T-frame stop when the lift ram is fully raised (10").

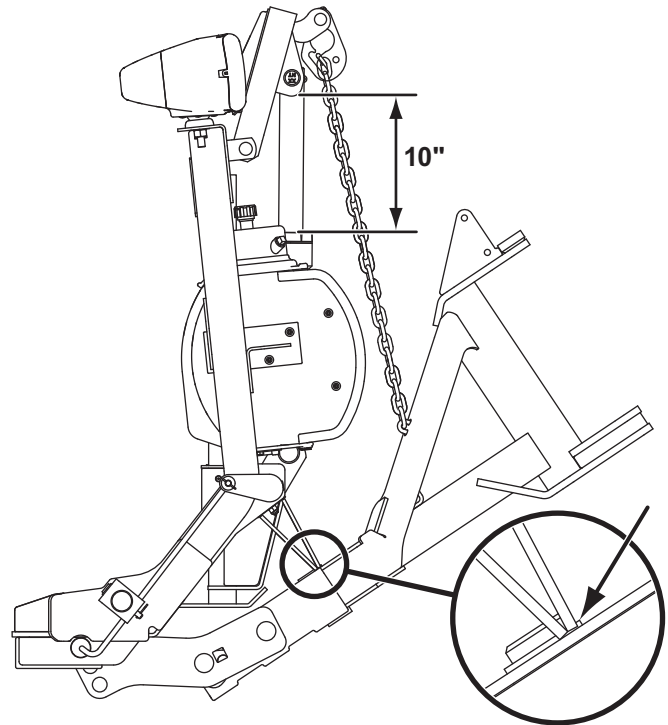

2. Remove and retain the U-bolt and locknuts securing the lift chain on the passenger's side of the T-frame. Reposition the U-bolt in the chain so that the chain is the same length as the chain on the driver's side.
3. Reinstall the U-bolt in the T-frame and tighten the locknuts. The chain link will pivot freely in the U-bolt.
4. Raise and lower the snowplow in retract (vee) position to verify that the hydraulic hoses bow outward and do not interfere with snowplow components.

NOTE: Ensure that the base-end angle ram hoses are wrapped over the diagonal brace. Adjust hoses, fittings, and wraps as necessary.

Connecting Link and Lift Chain Spring

When the blade is lowered, the lift chain spring provides slack in the lift chain for ease of mounting and dismounting the blade. Your snowplow application may use either a lap link or a quick link to connect the lift chain and spring.

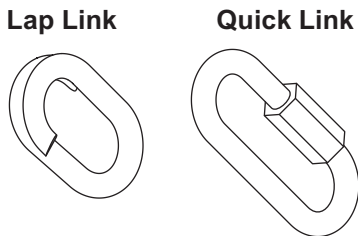

The lift chain spring is installed at the factory in the lift chain link number indicated in the table below.

XtremeV™ Snowplow	Number of Links from Driver-Side U-Bolt	
	Lap Link	Quick Link
T-Frame Type A	7	8
T-Frame Type B	7	8
T-Frame Type C	8	9

T-Frame Types

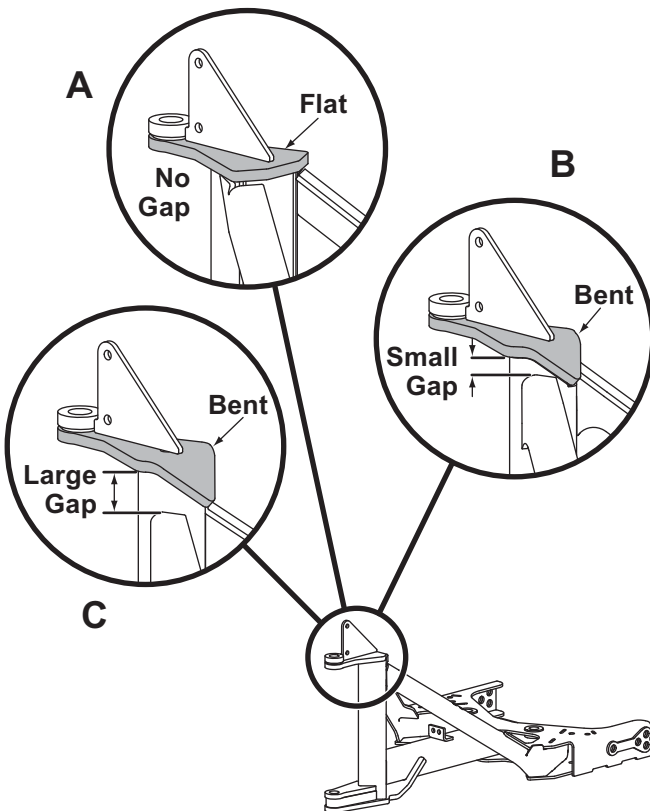

However, due to variations in vehicle frame height, it may be necessary to adjust the spring location to ensure optimal performance.

If you encounter mounting or dismounting difficulty, the attachment point of the connecting chain link and spring can be changed to a link on the lift chain that will add or remove slack from the lift chain.

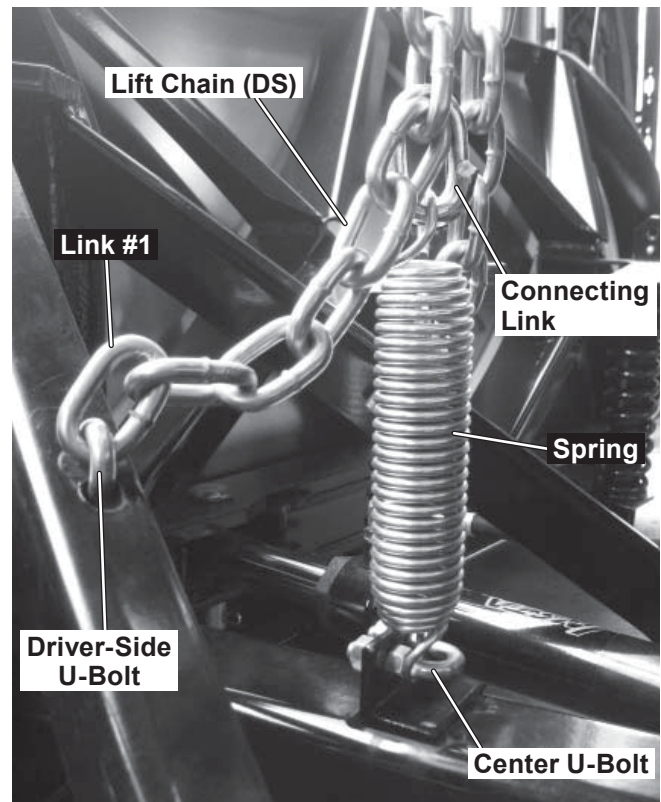

With the snowplow attached to a properly ballasted vehicle, make one of the following adjustments:

If there is not enough slack in the lift chain, there will be difficulty getting the connecting pins to engage the vehicle pushplates while pushing back on the headgear. Adjust the connecting link *up* one link from the factory setting.

If there is too much slack in the lift chain, adjust the connecting link *down* one link from the factory setting.

Moving the connecting chain link more than one chain link higher or lower than the factory installed location is not recommended.

VEHICLE LIGHTING CHECK

1. Verify the operation of all vehicle front lighting prior to connecting the snowplow harness.
2. Check the operation of the snowplow lights with snowplow mounted to vehicle and all harnesses connected.

Turn signals and parking lamps

Parking lamps ON:

- Both vehicle and snowplow parking lamps should be ON at the same time.

Driver-side turn signal ON:

- Both vehicle and snowplow driver-side turn signal lamps should flash at the same time.

Passenger-side turn signal ON:

- Both vehicle and snowplow passenger-side turn signal lamps should flash at the same time.

Headlamps

Move the vehicle headlamp switch to the "ON" position. Connecting and disconnecting the snowplow lighting harness plug should switch the lights between vehicle and snowplow as follows:

Snowplow lighting harness DISCONNECTED:

- Vehicle headlamps should be ON.
- Snowplow headlamps should be OFF.

Snowplow lighting harness CONNECTED:

- Snowplow headlamps should be ON.
- Vehicle headlamps should be OFF.

The dimmer switch should toggle headlamps between high and low beams. The high beam indicator on the dash should light when headlamps are placed in high beam.

Daytime Running Lamps (DRLs)

An operational check of the vehicle and snowplow DRLs will depend on the vehicle model, vehicle DRL system, and type of isolation module installed. Due to the variations in the OEM

DRL systems and the different isolation module options available, checking the functionality of the snowplow DRLs will depend on the type of module installed on the vehicle.

With the headlamp switch OFF, activate the vehicle DRLs.

Snowplow lighting harness DISCONNECTED:

- Vehicle DRLs should be ON.
- Snowplow headlamps should be OFF.

Snowplow lighting harness CONNECTED and vehicle in DRL mode:

- Check snowplow DRL function per the type of isolation module installed.

Refer to the Mechanic's Guide for information on the isolation module DRL functions.

Control power indicator light

The snowplow plugs **do** need to be connected to the vehicle harness connectors. The control power indicator light should light whenever the control ON/OFF switch and the ignition (key) switches are both in the "ON" position.

3. Connect all snowplow and vehicle harnesses. Raise the snowplow and aim the snowplow headlamps according to the Snowplow Headlamp Beam Aiming Instructions included with the headlamps, and any state or local regulations.
4. Check the aim of the vehicle headlamps with the snowplow removed.

⚠ CAUTION

On 2-plug electrical systems, plug covers shall be used whenever snowplow is disconnected. Vehicle battery cable is 12V unfused source.

5. When the snowplow is removed from the vehicle, install plug covers on the vehicle battery cable and lighting harness. Insert the snowplow battery cable and lighting harness into the cable boot on the snowplow.

OWNER'S MANUAL PACKET

If the completed snowplow will be delivered immediately, the Owner's Manual should be reviewed with and given to the purchaser according to the snowplow checklist.

If the snowplow is completed prior to delivery to the purchaser, attach the Owner's Manual packet to the electrical cable of the cab control for safekeeping.

Fisher Engineering reserves the right under its product improvement policy to change construction or design details and furnish equipment when so altered without reference to illustrations or specifications used. Fisher Engineering or the vehicle manufacturer may require or recommend optional equipment for snow removal. Do not exceed vehicle ratings with a snowplow. Fisher Engineering offers a limited warranty for all snowplows and accessories. See separately printed page for this important information. The following are registered (®) or unregistered (™) trademarks of Douglas Dynamics, LLC: FISHER®, Insta-Act®, Minute Mount® 2, XtremeV™.

Printed in U.S.A.
