



Fisher Engineering

50 Gordon Drive, Rockland, Maine 04841-2139 • www.fisherplows.com

50600

50810

April 15, 2010

Lit. No. 50579, Rev. 02



XLS™ SNOWPLOW

Installation Instructions

⚠ CAUTION

Read this document before installing the snowplow.

⚠ CAUTION

See your FISHER® outlet/Web site for specific vehicle application recommendations before installation. The Kit Selection Guide has specific vehicle and snowplow requirements.

SAFETY DEFINITIONS

⚠ WARNING

Indicates a potentially hazardous situation that, if not avoided, could result in death or serious personal injury.

⚠ CAUTION

Indicates a potentially hazardous situation that, if not avoided, may result in minor or moderate injury. It may also be used to alert against unsafe practices.

NOTE: Indicates a situation or action that can lead to damage to your snowplow and vehicle or other property. Other useful information can also be described.

WARNING/CAUTION AND INSTRUCTION LABELS

Become familiar with and inform users about the warning labels on the back of the blade and the instruction label on the headgear.

NOTE: If labels are missing or cannot be read, see your sales outlet.

Warning/Caution Label

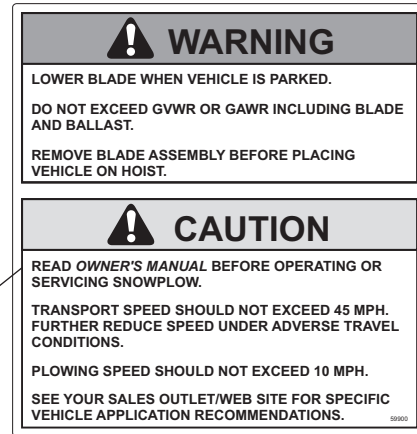

Instruction Label

1. Push **Pin Release Handle** down to pull out **Connecting Pins**.

2. Drive vehicle slowly to engage **Pushplates** into **Attachment Arms**.

3. Stand in front of blade. Fully raise **Pin Release Handle** to release **Connecting Pins**.

4. Push **Headgear** toward vehicle to allow **Connecting Pins** to fully engage **Pushplates**. If unable to push **Headgear** from in front of blade, stand in front of **Headgear** on driver side and push **Headlamp Bracket**.

5. Pull out **Jack Lock**. Push **Pin Release Handle** into **Stop**.

6. While holding **Jack Lock** out, use **Jack Handle** to raise **Jack** fully. Release **Jack Lock**.

7. Attach all electrical connectors.

ATTACH
DETACH

Read *Owner's Manual* For Complete Instructions

1. Place control in Lower/Float to put blade down.

2. Pull and hold **Jack Lock** out. **Jack** will drop to ground. Then pull **Pin Release Handle** away from **Stop** and **Jack Lock**. Release **Jack Lock**. Verify **Jack** is locked by trying to lift **Jack**.

3. Stand in front of blade. While pushing **Headgear** toward vehicle with left hand, push **Pin Release Handle** down to disengage **Connecting Pins**. Make sure **Connecting Pins** are fully retracted. If unable to push **Headgear** from in front of blade, stand in front of **Headgear** on driver side and push **Headlamp Bracket**.

4. Detach all electrical connectors.

27451

U.S. Patents 4,999,935; 5,353,530; 5,420,480; 6,253,470; 6,944,978; RE 35,700; CAN Patent 2,060,425; and other patents pending.

Multiple Pinch Points Label



XLS™ Blades Only (both sides)

SAFETY PRECAUTIONS

Improper installation and operation could cause personal injury and/or equipment and property damage. Read and understand labels and the Owner's Manual before installing, operating or making adjustments.

⚠ WARNING

Lower blade when vehicle is parked. Temperature changes could change hydraulic pressure, causing the blade to drop unexpectedly or damaging hydraulic components. Failure to do this could result in serious personal injury.

⚠ WARNING

The driver shall keep bystanders clear of the blade when it is being raised, lowered or angled. Do not stand between the vehicle and the blade or within 8 feet of a moving blade. A moving or falling blade could cause personal injury.

⚠ WARNING

Keep hands and feet clear of the blade and A-frame when mounting or removing the snowplow. Moving or falling assemblies could cause personal injury.

⚠ WARNING

Do not exceed GVWR or GAWR including blade and ballast. The rating label is found on driver-side vehicle door cornerpost.

⚠ WARNING

To prevent accidental movement of the blade, always turn the control OFF whenever the snowplow is not in use. The power indicator light will turn OFF.

⚠ WARNING

Remove blade assembly before placing vehicle on hoist.

⚠ CAUTION

Assembling a hose to the incorrect wing ram port can result in permanent damage to the ram.

⚠ CAUTION

Refer to the current Kit Selection Guide for minimum vehicle recommendations and ballast requirements.

HYDRAULIC SAFETY

⚠ WARNING

Hydraulic fluid under pressure can cause skin injection injury. If you are injured by hydraulic fluid, get medical attention immediately.

- Always inspect hydraulic components and hoses before using. Replace any damaged or worn parts immediately.
- If you suspect a hose leak, DO NOT use your hand to locate it. Use a piece of cardboard or wood.

FUSES

The FISHER® electrical and hydraulic systems contain several blade-style automotive fuses. If a problem should occur and fuse replacement is necessary, the replacement fuse must be of the same type and amperage rating as the original. Installing a fuse with a higher rating can damage the system and could start a fire. Fuse Replacement, including fuse ratings and locations, is located in the Maintenance Section of the Owner's Manual.

PERSONAL SAFETY

- Remove ignition key and put the vehicle in park or in gear to prevent others from starting the vehicle during installation or service.
- Wear only snug-fitting clothing while working on your vehicle or snowplow.
- Do not wear jewelry or a necktie, and secure long hair.
- Wear safety goggles to protect your eyes from battery acid, gasoline, dirt and dust.
- Avoid touching hot surfaces such as the engine, radiator, hoses and exhaust pipes.
- Always have a fire extinguisher rated BC handy, for flammable liquids and electrical fires.

FIRE AND EXPLOSION

⚠ WARNING

Gasoline is highly flammable and gasoline vapor is explosive. Never smoke while working on vehicle. Keep all open flames away from gasoline tank and lines. Wipe up any spilled gasoline immediately.

Be careful when using gasoline. Do not use gasoline to clean parts. Store only in approved containers away from sources of heat or flame.

CELL PHONES

A driver's first responsibility is the safe operation of the vehicle. The most important thing you can do to prevent a crash is to avoid distractions and pay attention to the road. Wait until it is safe to operate Mobile Communication Equipment such as cell phones or two-way radios.

VENTILATION

⚠ WARNING

Vehicle exhaust contains lethal fumes. Breathing these fumes, even in low concentrations, can cause death. Never operate a vehicle in an enclosed area without venting exhaust to the outside.

BATTERY SAFETY

⚠ CAUTION

Batteries normally produce explosive gases which can cause personal injury. Therefore, do not allow flames, sparks or lit tobacco to come near the battery. When charging or working near a battery, always cover your face and protect your eyes, and also provide ventilation.



Batteries contain sulfuric acid which burns skin, eyes and clothing.

Disconnect the battery before removing or replacing any electrical components.

TORQUE CHART

⚠ CAUTION

Read instructions before assembling. Fasteners should be finger tight until instructed to tighten according to torque chart. Use standard methods and practices when attaching snowplow including proper personal protective safety equipment.

Recommended Fastener Torque Chart (ft-lb)			
Size	 SAE Grade 2	 SAE Grade 5	 SAE Grade 8
1/4-20	6	9	13
5/16-18	11	18	28
3/8-16	19	31	46
3/8-24	24	46	68
7/16-14	30	50	75
1/2-13	45	75	115
9/16-12	66	110	165
5/8-11	93	150	225
3/4-10	150	250	370
7/8-9	150	378	591
1-8	220	583	893
Metric Grade 8.8 (ft-lb)			
Size	Torque	Size	Torque
M 6	7	M 12	60
M 8	17	M 14	95
M 10	35	M 16	155
These torque values apply to fasteners except those noted in the instruction.			

BLADE, A-FRAME AND HEADGEAR

1. Remove the headlamp box and small parts box from the carton. Remove the carton wall sleeve by sliding it up and over the box contents. Remove and discard the four corner tubes and place the sleeve flat on the floor. Remove the headgear and power unit assembly from the box and place it on the carton sleeve. Remove the A-frame and place it on the carton sleeve.
2. Place some cardboard or wood on the floor where the blade will be assembled. Remove the blade from the pallet and place it face down. Position the A-frame assembly so that the holes in the A-frame are aligned with the holes in the blade. Insert the pivot bolt (from top to bottom) through all holes. Secure with a 1" locknut and tighten.

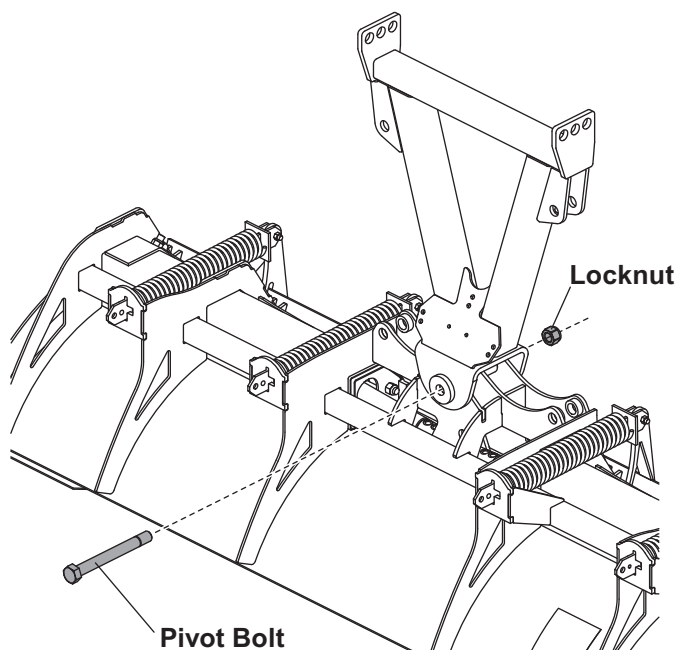

3. Cut the tie holding the angle rams to the A-frame. Remove the protective caps on the angle rams. Swing the A-frame to one side so that the holes in the rod end of the angle ram and the blade are aligned.

4. Install a 1" x 4-3/4" clevis pin from the top down. Swing the A-frame to the other side and secure the second angle ram in the same manner. Secure the angle rams by installing 1/4" x 1-1/2" cotter pins in the two rod-end clevis pins.

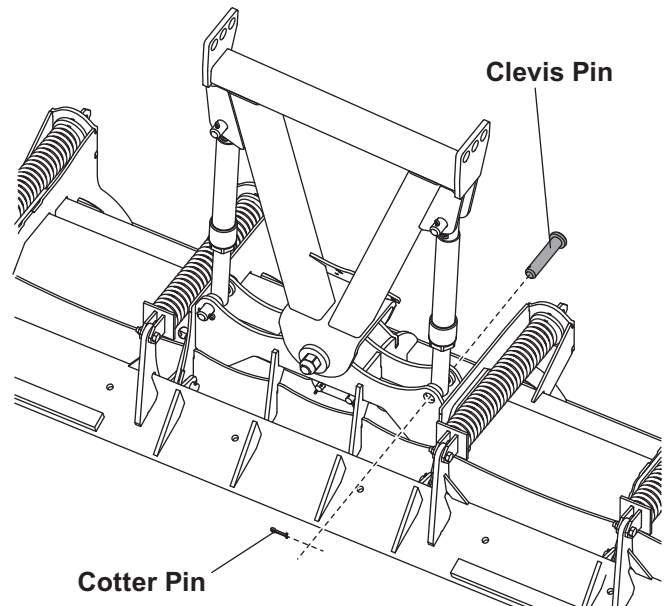

5. Remove the 1" x 4" clevis pin from the base end of one of the angle rams and install the fitting as shown.

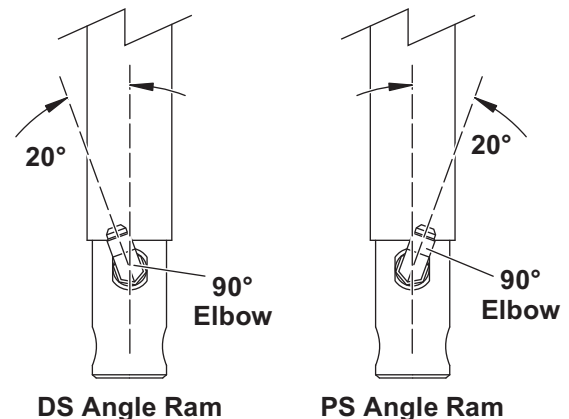

Reattach the base end of the angle ram with a 1" x 4" clevis pin and secure with a 1-1/2" cotter pin. Repeat this process for the second angle ram.

For blades built after March 2, 2010, these fittings are pre-installed and the cylinders are pre-filled with hydraulic fluid. The build date can be found in the first six digits of the serial number, located in the upper right corner on the back of the blade (YYMMDD: YY = 2-digit year, MM = 2-digit month, DD = 2-digit day).

6. Stand the blade and A-frame upright and support in a level position using block under the main A-frame tube. Install the blade guides.

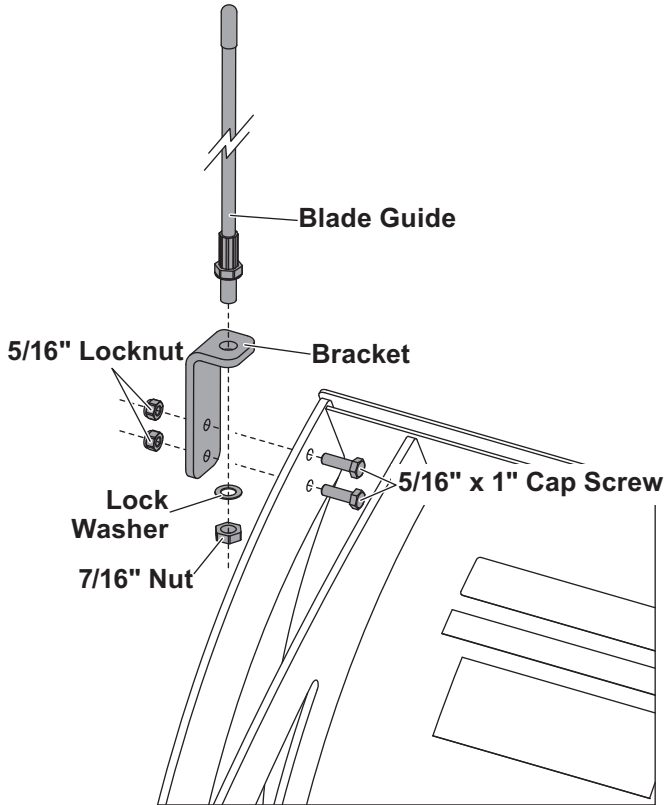

7. Install a 3/8" U-bolt through a link in one end of the lift chain. Attach U-bolt and chain to the holes on the driver-side A-frame brace with 3/8" lock washers and nuts. Tighten.

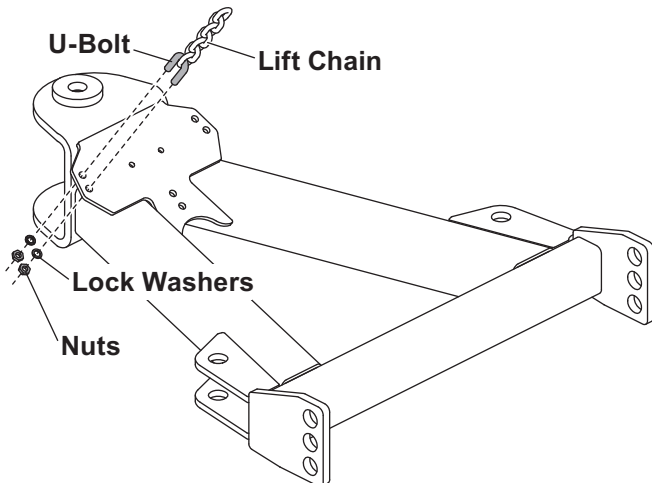

8. Place a U-bolt on the extension spring. Attach a 3/8" nut on each side of the U-bolt. Insert the U-bolt through the mounting tab on the A-frame. Place lock washers and 3/8" nuts on the U-bolt and tighten.

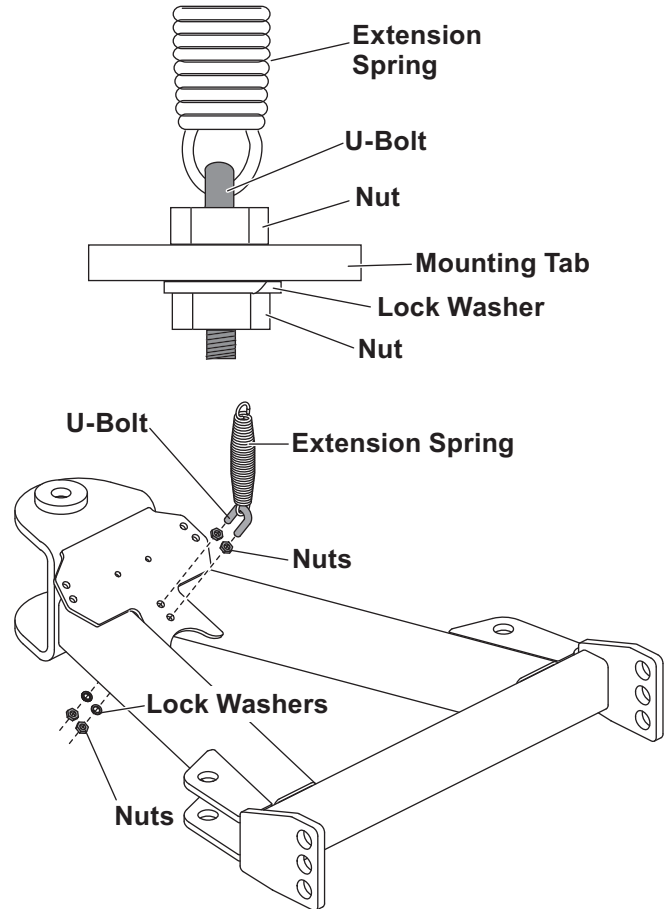

9. Remove the support block from under the A-frame and lower the A-frame to the ground, again placing it on the carton sleeve.

10. With the vehicle parked on a solid level surface, measure the distance from the center of the connecting pin hole to the ground. Using this measurement refer to the hole selection chart and determine which hole should be used to attach the headgear to the A-frame.

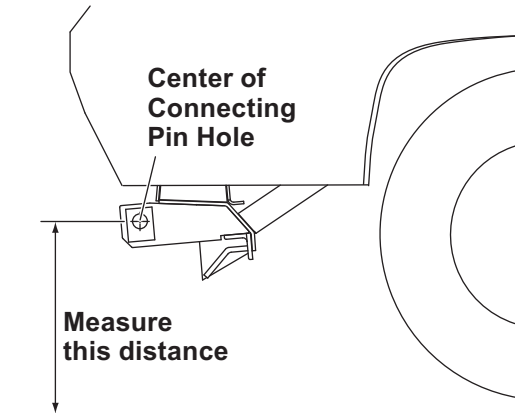

Pushplate Height (hole center to ground)	Rear Hole
17" to 19"	Top
15" to 17" (typical)	Middle
13" to 15"	Bottom

11. Lower the jack leg in the headgear assembly so that six complete slots are showing through the top of the headgear cross bar. Release the jack lock to hold the jack in place. Place the headgear assembly on top of the A-frame assembly so the headgear is tipped backward and the jack leg is in

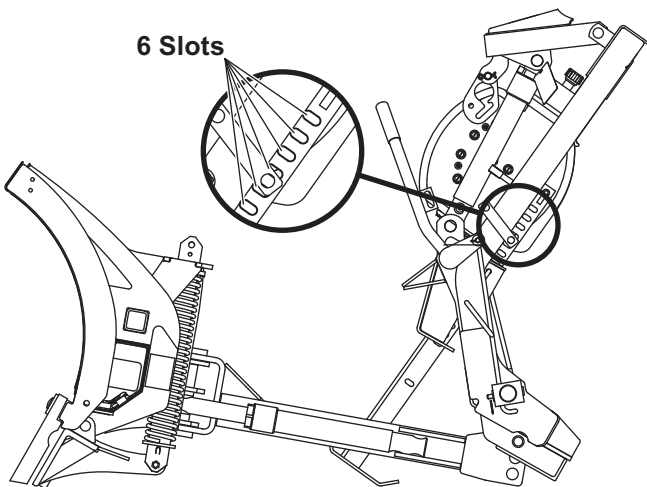

- between the A-frame and push assembly. Attach the jack handle to the jack with a 3/8" lock washer and nut.

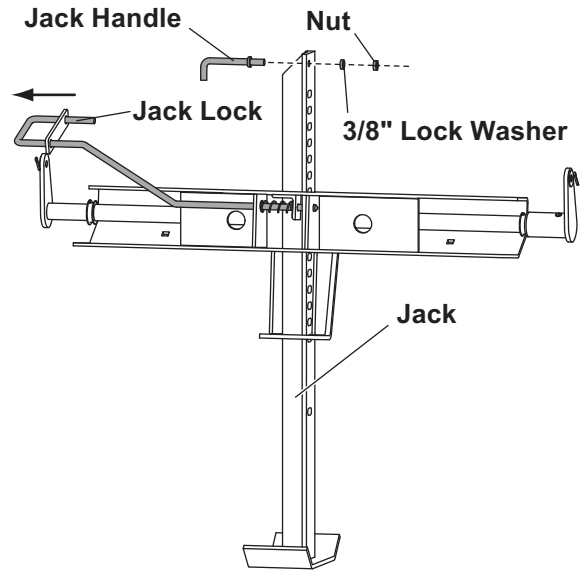

12. Position the headgear so that the holes in the headgear are aligned with the previously selected holes in the push assembly. Attach the A-frame to the headgear assembly with two step pins and 1/4" x 1-1/2" cotter pins. Insert the step pins from the outside of the headgear.

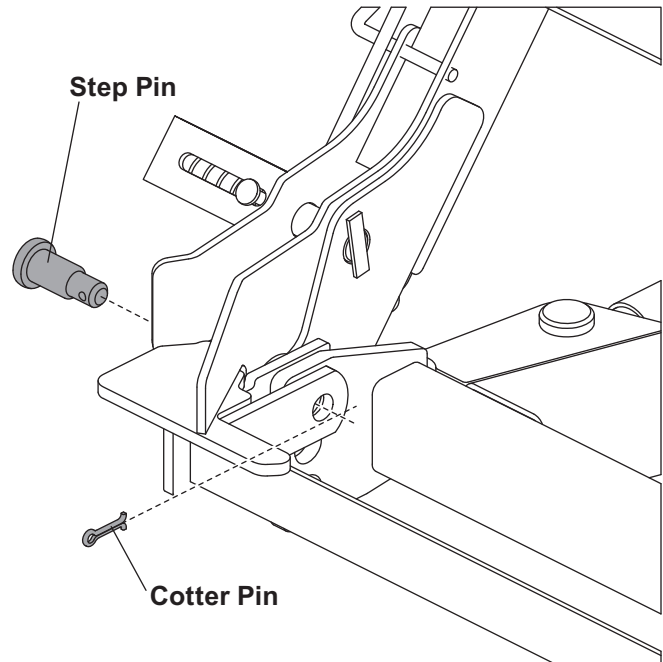

13. If the lowest set of holes in the push assembly are used, the stacking stops attached to the lift frame can be removed.

HYDRAULIC FITTINGS

Do not use thread sealant/tape on hoses and fittings. This could damage the product. Install all fittings into rams and hydraulic unit using the following procedure and fitting orientation illustrations:

1. Remove the plug from ram or manifold port. Use a rag to catch residual fluid when removing the manifold plugs.
2. Turn the jam nut on the fitting as far back as possible.
3. Lubricate the O-ring with clean hydraulic fluid.

4. Install the hexagonal orifice plate under each of the two wing rod fittings as shown below. The slot in the orifice plate must face the manifold. Installing the orifice plates backwards will cause blade wings to "chatter" when retracting.
5. Screw the fitting into the port by hand as far as it will go. The washer should contact the port face and shoulder of the jam nut threads.
6. Unscrew the fitting to proper position, no more than one full turn.
7. Use one wrench to hold the fitting body in position and tighten the jam nut with another wrench until the washer again contacts the port face. Tighten 1/8–1/4 turn to lock the fitting in place.

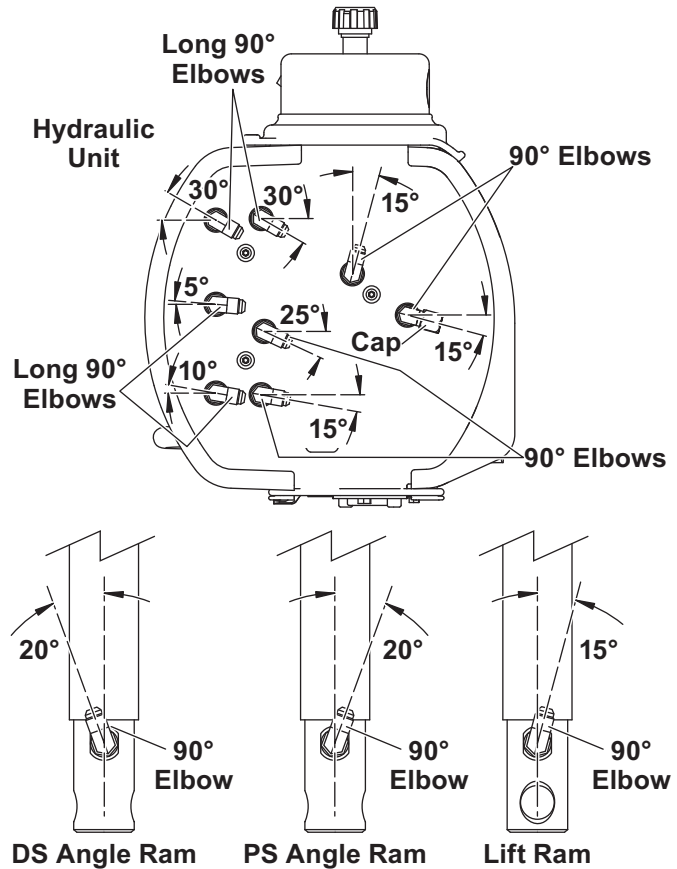
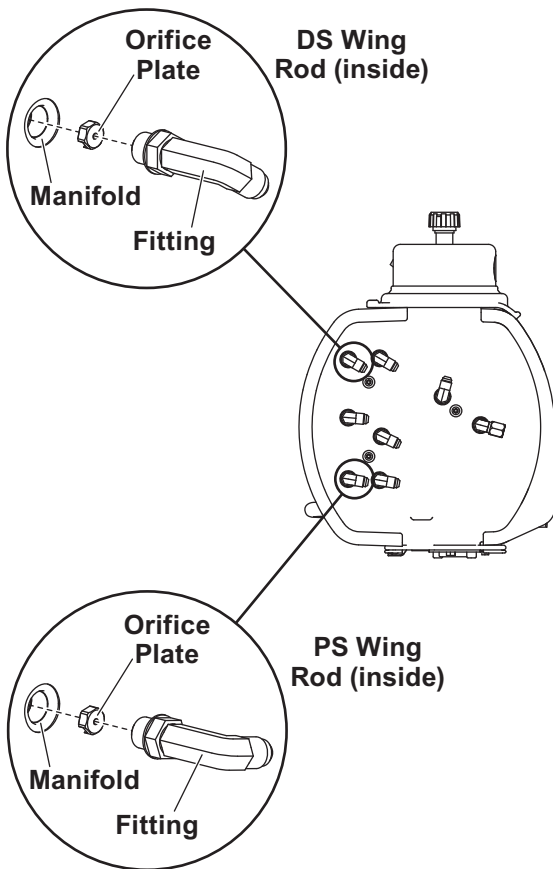

For blades built after March 2, 2010, these fittings are pre-installed and the cylinders are pre-filled with hydraulic fluid. The build date can be found in the first six digits of the serial number, located in the upper right corner on the back of the blade (YYMMDD: YY = 2-digit year, MM = 2-digit month, DD = 2-digit day).

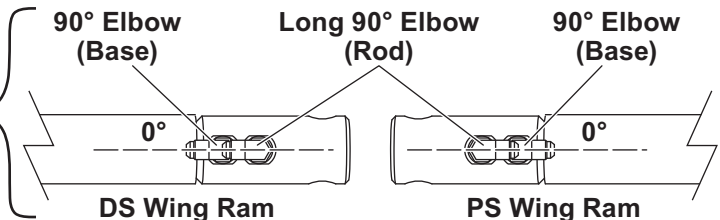

HYDRAULIC HOSES

Do not use thread sealant/tape on hoses and fittings. This could damage the product.

1. Apply the caution label to each wing hose near the wing ram fitting, as shown below.

CAUTION! Verify hoses from cylinder are connected to correct manifold port or cylinder will bend. The extend port is closest to the rod and the retract port is closest to the base.

CAUTION

Wrap label around hose and press ends together.

CAUTION! Verify hoses from cylinder are connected to correct manifold port or cylinder will bend. The extend port is closest to the rod and the retract port is closest to the base.

3. Apply two protective hose wraps to each group of hoses from the fitting side of the hydraulic unit around and behind the jack leg and hydraulic unit and over the headgear to the front. Apply one hose wrap to each set of wing ram hoses beginning near the wing ram fittings.

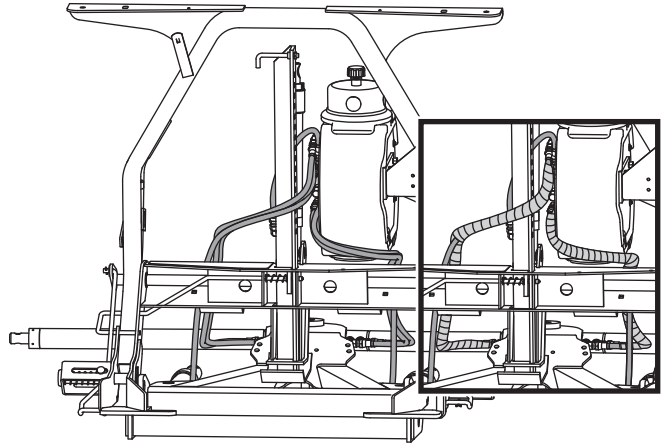

CAUTION
Assembling a hose to the incorrect wing ram port can result in permanent damage to the ram.

2. Attach all hoses to fittings, routing hoses as shown. Leave the hoses finger tight at this time.

For blades built after March 2, 2010, remove and discard the fitting caps from the blade extension cylinder fittings prior to attaching hoses. The build date can be found in the first six digits of the serial number, located in the upper right corner of the back of the blade (YYMMDD: YY = 2-digit year, MM = 2-digit month, DD = 2-digit day).

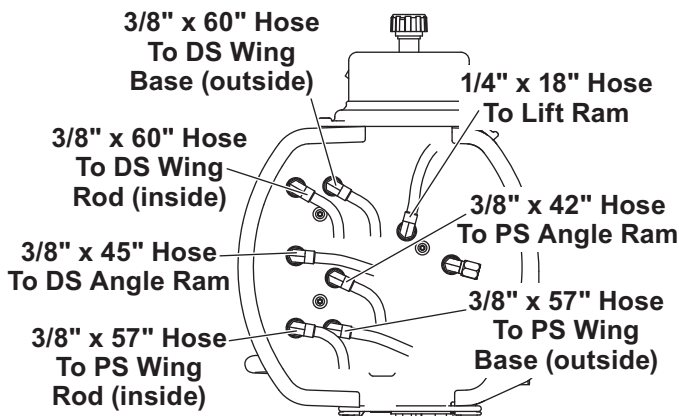
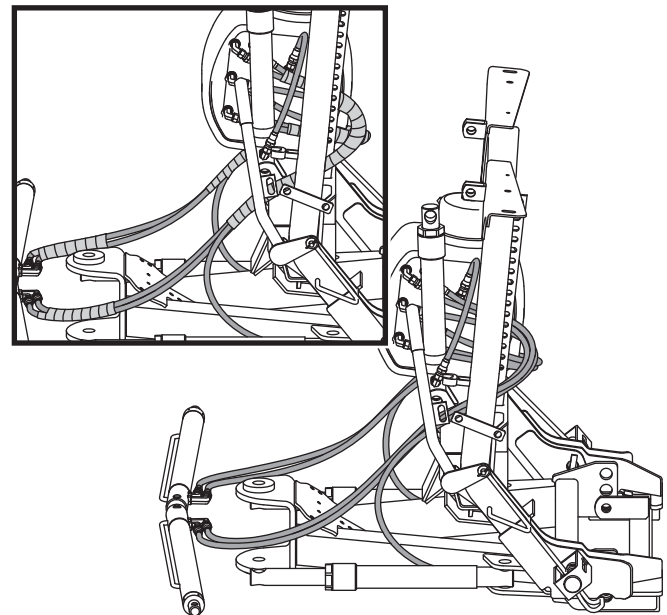

4. Using a wrench to hold the hose end in position, tighten all hose fittings 1/8–1/4 turn past finger tight.

LIFT CHAIN AND CABLE

1. Complete the installation of the lift chain by inserting the loose end of the lift chain through the stop link on the lift arm. Fasten to opposite holes in the A-frame brace using a 3/8" U-bolt, lock washers and nuts. Hand tighten.
2. Insert the cable down through the hole in the strap fork. Attach the strap fork to the hole in the stop link on the lift arm with a 3/8" x 1" clevis pin and 1/8" x 1" cotter pin. Slip the cable thimble onto the top loop in the spring previously installed in the front of the A-frame.

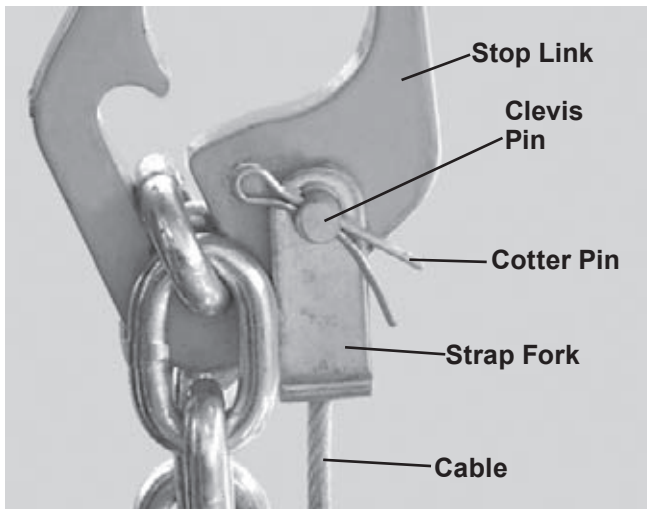

NOTE: The slotted end of the thimble may need to be opened to slip it onto the loop. Fully close the slot after attaching the thimble to the spring.

3. Loop the end of the cable around the thimble. Pull the cable up against the thimble until the slack is removed. Attach the end of the cable back onto itself with two cable clamps loosely installed close to the thimble as shown.



Due to varying vehicle heights, the length of the cable must be adjusted for the vehicle in the Final Adjustments section at the end of these instructions.

HEADLAMPS

⚠ WARNING

Your vehicle must be equipped with snowplow headlamps and directional lights.

Headlamps, hardware and instructions are found in the headlamp box.

1. Attach the headlamps to the hole and slot in the headgear light bracket by following the instructions included with the headlamps.
2. Secure the snowplow harnesses and cables to the headgear as shown.

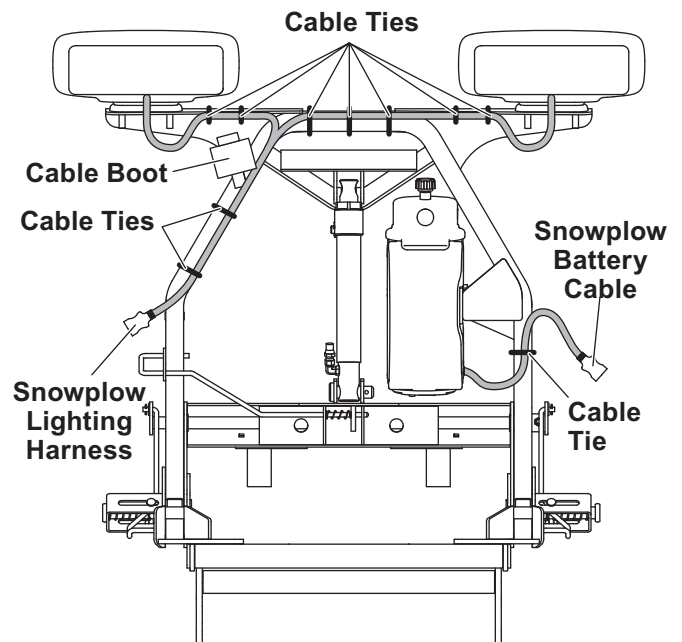

3. Install the cable boot onto the headgear bracket.

FILLING HYDRAULIC UNIT

⚠ WARNING

Keep 8' clear of the blade drop zone when it is being raised, lowered or angled. Do not stand between the vehicle and blade or directly in front of blade. If the blade hits you or drops on you, you could be seriously injured.

1. Attach the snowplow to the vehicle according to the instructions on the headgear.
2. With wing and lift rams fully retracted, fill the reservoir with FISHER® EZ Flow Hydraulic Fluid to -40°F (-40°C), or other fluid conforming to Military Specification MIL-H-5606A, such as Mobil Aero HFA or Shell AeroShell® Fluid 4. Replace the fill plug.

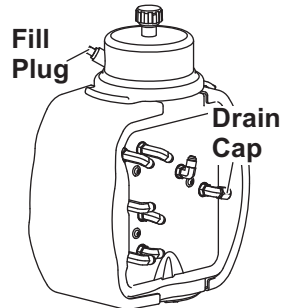

NOTE: Add fluid only when all rams are retracted.

⚠ WARNING

To prevent accidental movement of the blade, always turn the control OFF whenever the snowplow is not in use. The power indicator light will turn OFF.

⚠ CAUTION

DO NOT raise blade at this time as this may cause pump cavitation.

3. Turn the control ON and completely extend and retract the driver-side wing several times. Repeat for the passenger-side wing. With wings and lift ram fully retracted, turn the control OFF.

⚠ CAUTION

Do not mix different types of hydraulic fluid. Some fluids are not compatible and may cause performance problems and product damage.

4. Fill the reservoir with hydraulic fluid. Replace the fill plug.

NOTE: Remove fill plug slowly to relieve any pressure in reservoir.

5. Turn the control ON and raise and lower the snowplow several times. Activate the control FLOAT function and manually collapse the lift ram all the way after each lowering of blade. Angle the blade fully to the left and right several times. With wing and lift rams fully retracted, turn the control OFF.
6. Fill the reservoir to the top of the fill hole and replace the fill plug.

FLUID CAPACITY

- | | |
|-----------------------------|-----------------------|
| • Insta-Act® Unit Reservoir | 1-3/4 quarts |
| • Insta-Act System Total | 2-3/8 to 2-3/4 quarts |

BLADE DROP SPEED ADJUSTMENT

⚠ WARNING

Keep 8' clear of the blade drop zone when it is being raised, lowered or angled. Do not stand between the vehicle and blade or directly in front of blade. If the blade hits you or drops on you, you could be seriously injured.

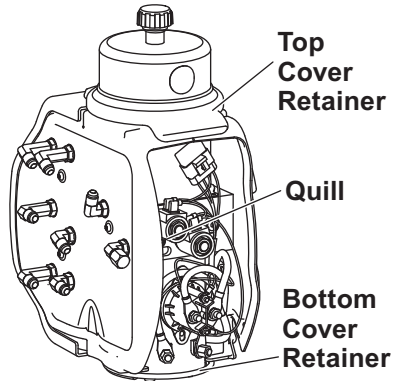

The quill in the valve manifold adjusts the blade drop speed.

1. Lower the blade to the ground before making adjustment.
2. Turn the quill IN (clockwise) to decrease drop speed. Turn the quill OUT (counterclockwise) to increase drop speed.

NOTE: To access the quill on the XLS™ hydraulic unit, raise top cover retainer, remove bottom cover retainer and remove rear cover.

3. Stand 8' clear of the blade drop zone when checking adjustment.
4. On the XLS unit, replace the cover and reinstall the top and bottom cover retainers.

FINAL ADJUSTMENTS

1. With the snowplow attached to the properly ballasted vehicle and the blade lowered to the ground, the A-frame should be parallel with the ground.
2. Adjust the length of the lift chain so the A-frame hits the A-frame stop when the lift ram is fully raised (10"). Tighten U-bolts.

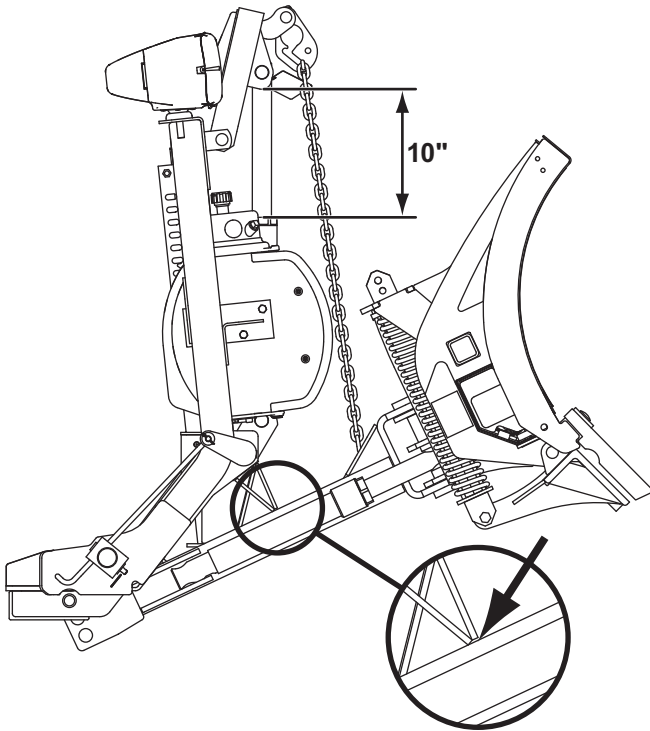

3. For reliable operation, and to prevent damage to the 6-1/2" lift arm extension spring, the length of the cable must be adjusted when attached to the vehicle it will be used on. With the lift ram fully collapsed, wrap the cable tightly around the thimble, shorten/lengthen the cable to remove all slack from the cable, then tighten the cable clamps.
4. After adjustment, the excess cable should be trimmed off close to the second cable clamp. Cover the cut end of cable with electrical tape. Excessive spring tension will make attaching/detaching difficult and overextend the spring.
5. Fully angle the blade in raised and lowered positions. Adjust hose fittings and wraps so hoses do not contact vehicle bumper, have no sharp bends and are wrapped at contact points with the headgear and blade.

VEHICLE LIGHTING CHECK

1. Verify the operation of all vehicle front lighting prior to connecting the snowplow harness.
2. Check the operation of the snowplow lights with snowplow mounted to vehicle and all harnesses connected.

Turn signals and parking lamps

Parking lamps ON:

- Both vehicle and snowplow parking lamps should be ON at the same time.

Driver-side turn signal ON:

- Both vehicle and snowplow driver-side turn signal lamps should flash at the same time.

Passenger-side turn signal ON:

- Both vehicle and snowplow passenger-side turn signal lamps should flash at the same time.

Headlamps

Move vehicle headlamp switch to the "ON" position. Connecting and disconnecting the snowplow lighting harness plug should switch the lights between vehicle and snowplow as follows:

Snowplow lighting harness DISCONNECTED:

- Vehicle headlamps should be ON.
- Snowplow headlamps should be OFF.

Snowplow lighting harness CONNECTED:

- Snowplow headlamps should be ON.
- Vehicle headlamps should be OFF.

Dimmer switch should toggle headlamps between high and low beams. The high beam indicator on the dash should light when headlamps are placed in high beam.

Daytime Running Lamps (DRLs)

An operational check of the vehicle and snowplow DRLs will depend on the vehicle model, vehicle DRL system and type of Isolation Module installed. Due to the variations in the OEM DRL systems and the different Isolation Module

options available, checking the functionality of the snowplow DRLs will depend on the type of module installed on the vehicle.

With headlamp switch OFF, activate the vehicle DRLs.

Snowplow lighting harness DISCONNECTED:

- Vehicle DRLs should be ON.
- Snowplow headlamps should be OFF.

Snowplow lighting harness CONNECTED and vehicle in DRL mode:

- Check snowplow DRL function per the type of Isolation Module installed.

Refer to the Mechanic's Guide for information on the Isolation Module DRL functions.

Hand-Held Control

The snowplow plugs **do** need to be connected to the vehicle harness connectors. The control power indicator light should light whenever the control ON/OFF switch and the ignition (key) switches are both in the "ON" position.

3. Connect all snowplow and vehicle harnesses. Raise the snowplow and aim snowplow headlamps according to the Snowplow Headlamp Beam Aiming instructions included with the headlamps and any state or local regulations.
4. Check aim of vehicle headlamps with snowplow removed.

CAUTION

On 2-plug electrical systems, plug covers shall be used whenever snowplow is disconnected. Vehicle Battery Cable is 12-volt unfused source.

5. When the snowplow is removed from the vehicle, install plug covers on the vehicle battery cable and lighting harness. Insert the snowplow battery cable and lighting harness into the cable boot on the snowplow.

OWNER'S MANUAL PACKET

If the completed snowplow will be delivered immediately, the Owner's Manual should be reviewed with and given to the purchaser.

If the snowplow is completed prior to delivery to the purchaser, attach the Owner's Manual Packet to the electrical cable of the cab control for safekeeping.

Fisher Engineering reserves the right under its product improvement policy to change construction or design details and furnish equipment when so altered without reference to illustrations or specifications used. Fisher Engineering or the vehicle manufacturer may require or recommend optional equipment for snow removal. Do not exceed vehicle ratings with a snowplow. Fisher Engineering offers a limited warranty for all snowplows and accessories. See separately printed page for this important information. The following are registered (®) or unregistered (™) trademarks of Douglas Dynamics, L.L.C.: FISHER®, Insta-Act®, Minute Mount® 2, XLS™.

Printed in U.S.A.
