

SERIES FORD F350
 G & H FORD F250 LOW PROFILE
 FORD F150 SUPERCAB

1979
 1977-1/2-1979
 1978-1979

AL227
 REV D

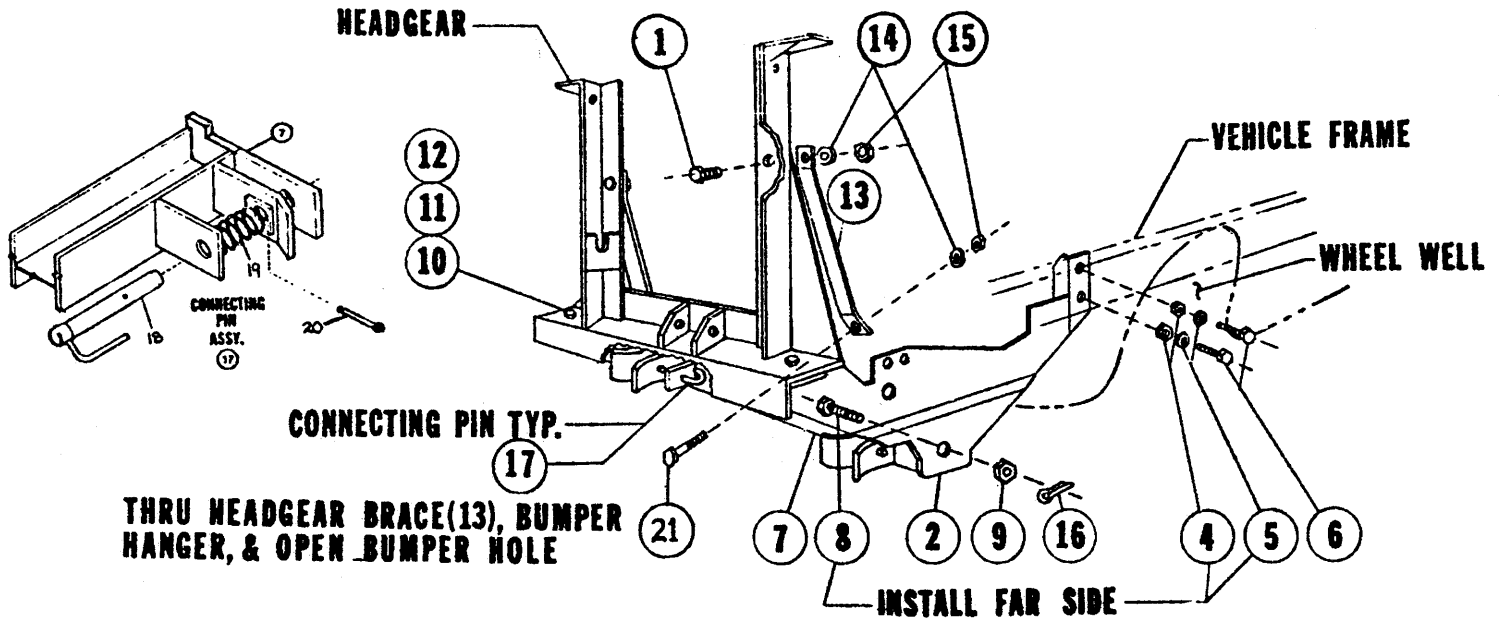

6264

REF#	PART#	QTY	DESCRIPTION * PART OF 6808 BOLT BAG
1	90244	2	* 5/8-11 X 1-1/2 (NC) GR.5 CAPSCREW
2	5035	1	DRIVER SIDE PUSHPLATE
3	5031	1	PASSENGER SIDE PUSHPLATE
4	90353	2	* 7/16-14 (NC) SELF LOCKING NUT
5	90317	4	* 7/16" FLATWASHER
6	90199	2	* 7/16-14 X 5 (NC) GR.5 CAPSCREW (DR. SIDE ONLY)
7	1513	1	PUSHBEAM (27" OVERALL LENGTH)
8	5005	2	* 5/8-11 X 1-1/2 (NC) DRILLED CAPSCREW
9	90446	2	* 5/8-11 (NC) SLOTTED NUT
10	90210	2	* 1/2-13 X 1-1/2 (NC) GR.5 CAPSCREW
11	90364	2	* 1/2 LOCKWASHER
12	90337	2	* 1/2-13 (NC) NUT
13	5033	2	HEADGEAR BRACE
14	90366	4	* 5/8 LOCKWASHER
15	90343	4	* 5/8-11 (NC) NUT
16	90012	2	* 3/16 X 1-3/4 COTTER PIN
17	6920	2	CONNECTING PIN ASSEMBLY
18	6815	2	CONNECTING PIN W/HANDLE
19	821	2	* SPRING
20	90601	2	* 1/4 X 1-1/2 COTTER PIN
	4289	2	* 3/4 X 1-7/8 MACHINE PIN
	90658	2	* 5/32 X 1-1/4 COTTER PIN
	7275	1	* 5/16" REPAIR LINK
	7274	1	* 12" LENGTH OF CHAIN
	3	1	CONNECTING PIN RELEASE
21	90249	2	* 5/8 X 2-1/2 (NC) GR.5 CS
	A5941	1	DASH BRACKET BAG

NOTE: DO NOT JACK VEHICLE UP.

A. REMOVE THE TWO INSIDE 1/2" LOCKNUTS FROM BOTH FRONT SPRING MOUNTS.
ON SIX CYLINDER MODELS: REMOVE TWO FRONT 7/16" LOCKNUTS FROM BOTH ENGINE MOUNTS AND BEND DOWN THE SMALL GUSSETS ON FRONT LOWER EDGE OF ENGINE MOUNTS.

ON V8 MODELS: REMOVE TWO 7/16 LOCKNUTS FROM SHOCK ABSORBER MOUNT ON PASSENGER SIDE ONLY. REMOVE LOWER BUMPER MOUNTING BOLTS & DISCARD (ONE EACH SIDE).

B. INSTALL DRIVER'S SIDE PUSHPLATE (2) INSIDE BOTH FRAME AND SPRING INSERTING THE TWO HOLES IN FORWARD SECTION OF PUSHPLATE OVER THE TWO 1/2" BOLTS IN FRONT SPRING MOUNT. SCREW LOCKNUTS (REMOVED IN STEP A) FINGER TIGHT.

ON V8 MODELS: INSTALL TWO 7/16 X 5 GR.5 CAPSCREW (6) FROM OUTSIDE OF FRAME THROUGH FRAME AND REAR ANGLE BRACKET OF PUSHPLATE IN HOLES LOCATED APPROXIMATELY 3-1/2" FORWARD FROM ENGINE MOUNT BOLTS. INSTALL FLATWASHERS (5) & LOCKNUTS (4), LEAVE FINGER TIGHT.

ON 6 CYLINDER MODELS: INSTALL REAR ANGLE BRACKET AND FLATWASHER (5) OVER FRONT TWO ENGINE MOUNT BOLTS AND SCREW ON LOCKNUTS (REMOVED IN STEP A) FINGER TIGHT.

NOTE: ON 6 CYLINDER MODELS THE TWO 7/16 X 5 GR.5 CAPSCREWS (6) AND LOCKNUTS (4) PROVIDED ARE NOT USED.

C. INSTALL PASSENGER'S SIDE PUSHPLATE (3) IN SAME MANNER AS DRIVER'S SIDE.

ON V8 MODELS: THE REAR ANGLE BRACKET OF PUSH-PLATE BOLTS TO SHOCK MOUNT BOLTS.

ON 6 CYLINDER MODELS: THE REAR ANGLE BRACKET OF PUSHPLATE BOLTS TO THE TWO FRONT ENGINE MOUNT - SHOCK MOUNT BOLTS. REINSTALL THE LOCKNUTS REMOVED IN STEP "A" AND LEAVE FINGER TIGHT.

D. ASSEMBLE CONNECTING PINS (17) TO PUSHBEAM (7). FIRST INSERT SPRINGS (19) BETWEEN TWO INNER EARS ON EACH SIDE OF PUSHBEAM. THEN INSERT CONNECTING PIN (18) THROUGH ALL THREE EARS WITH HANDLE OF PIN TOWARDS THE CENTER OF THE BEAM. LEAVING THE HOLE IN THE PIN BETWEEN THE INNER TWO EARS, PULL BACK ON SPRING AND INSTALL COTTER PIN (20).

E. INSTALL PUSHBEAM (7) BETWEEN PUSHPLATES (2,3) USING DRILLED 5/8 X 1-1/2 CAPSCREWS (8) INSERTED FROM INSIDE AND SLOTTED NUTS (9) OUTSIDE.

F. INSTALL HEADGEAR ON FRONT PUSHPLATE TABS USING 1/2 X 1-1/2 CAPSCREWS (10), LOCKWASHERS (11) AND NUTS (12).

G. INSTALL 5/8 X 2-1/2 (NC) CAPSCREW THROUGH HEADGEAR BRACE (13), BUMPER HANGER, AND OPEN LOWER BUMPER MOUNTING HOLE. (REAM BUMPER HOLE TO 21/32" DIA). SECURE FINGER TIGHT WITH 5/8 LOCKWASHER (14) AND NUT (15). SHORTER BENT END OF BRACES ATTACHED TO HEADGEAR WITH TWO 5/8 X 1-1/2 (NC) CAPSCREWS (1), LOCKWASHERS (14) AND NUTS (15).

H. TIGHTEN PUSHBEAM BOLTS AND NUTS AND SECURE USING 3/16 X 1-3/4 COTTER PINS (16). TIGHTEN ALL OTHER CAPSCREWS AND NUTS.

NOTE: HEADGEAR IS PACKED IN COMMON ATTACHINGS BOX.