

6298

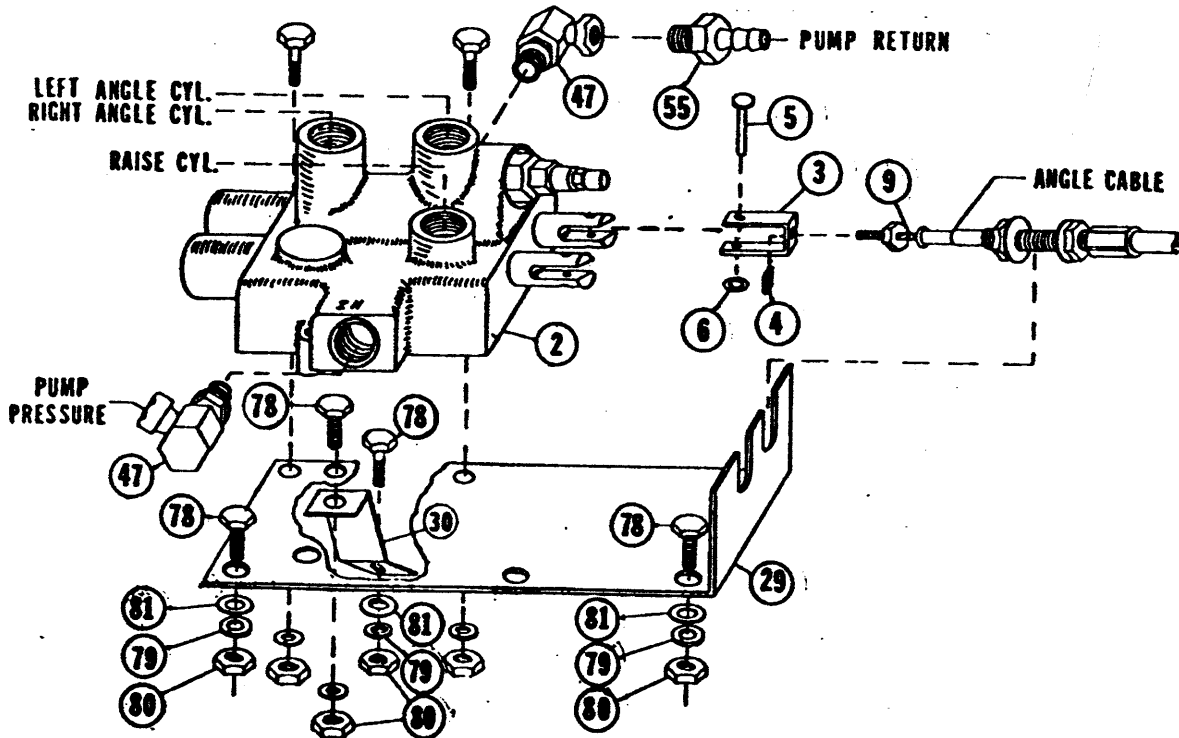

SERIES  
B

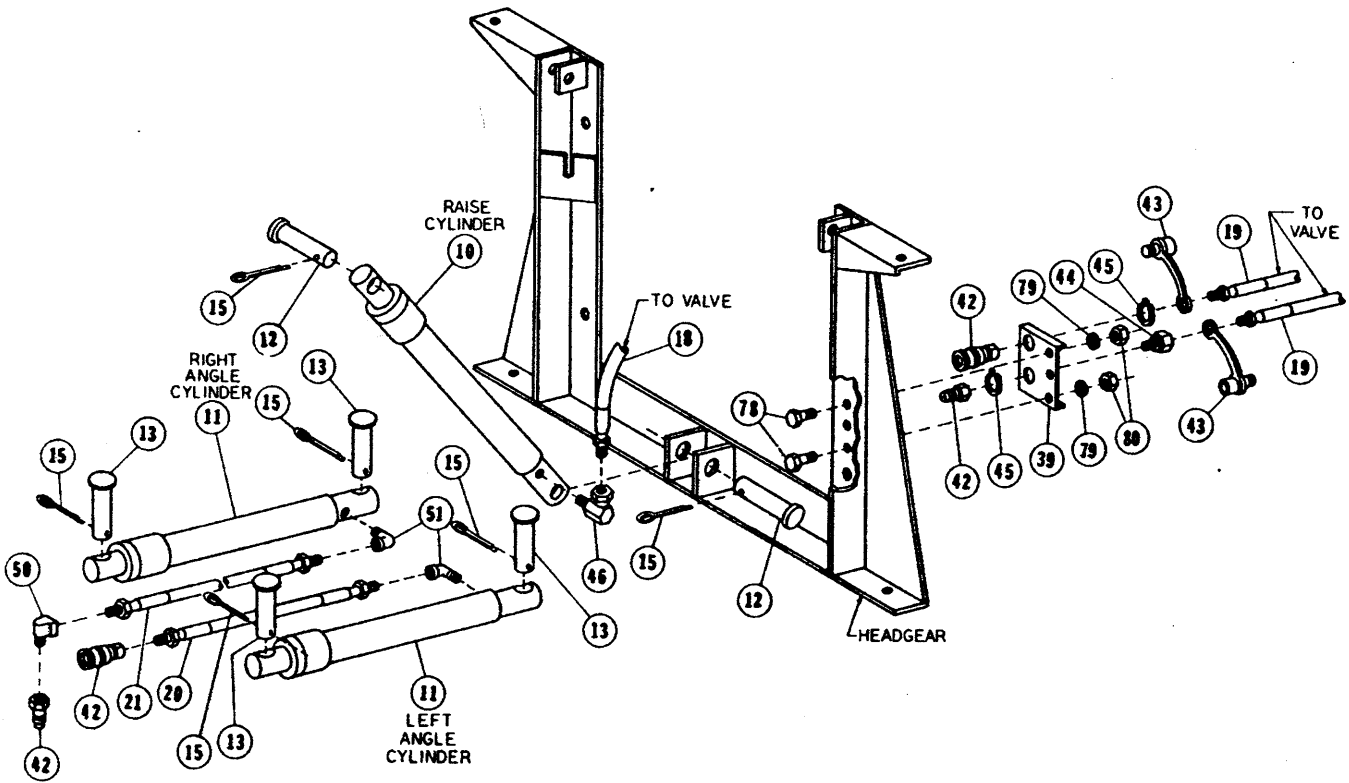

HYDRAULICS PARTS LIST

HPS4586  
A4468

REF#	QUAN	IN KIT	PART#	DESCRIPTION
	A4468-40	HPS4586		* PART OF 6917 BOLT BAG
1	1		A2311	PUMP TANK ASSEMBLY
2	1		A4466	CONTROL VALVE ASSEMBLY
3	2		4483	CLEVIS
4	2		4494	10-32 SQUARE NUT
5	2		4491	CLEVIS PIN
6	2		4493	3/16 PUSH NUT
7				
8		1	4419	SINGLE LEVER CONTROL HEAD
9		2	4949	30" CONTROL CABLE, SLC
10	1		A318	10" LIFT CYLINDER ASSEMBLY
11	2		A3660	12" ANGLE CYLINDER ASSEMBLY
12	2		6814	CLEVIS PIN
13	4		6816	ANCHOR PIN
14				
15	6		90601	1/4 X 1-1/2 COTTER PIN
16		1	2504	60" H.P. HOSE, 1/4P TO 3/8P
17		1	2519	66" L.P. HOSE
18		1	1665	60" H.P. HOSE, 9/16 O-RING TO 1/4P
19		2	1664	54" H.P. HOSE, 9/16 O-RING TO 1/4P
20		1	376	32" H.P. HOSE, 1/4P TO 1/4P
21		1	4424	36" H.P. HOSE, 1/4P TO 1/4P
22				
23		1	1022	FAN BELT, 55"
24		1	7456	DRIVE SHEAVE
25		1	3696	PUMP SHEAVE
26		1	6069	PUMP BRACKET
27				
28				
29		1	5329	VALVE PLATE
30		1	4476	VALVE PLATE BRACE
31				
32				
33				
34				
35		1	5495	SADDLE BRACKET
36	1		2036	REAR TANK STRAP
37	1		2116	UNIVERSAL BRACE ROD
38		1	* 2115	UNIVERSAL BRACE TAB
39		1	4467	DISCONNECT MOUNTING PLATE
40				
41				
42	2		A1587	DISCONNECT ASSEMBLY
43	2		1588	DUST PLUG
44		1	* 4486	BULKHEAD ADAPTER
45		2	* 4485	7/8" SNAP RING
46	1		319	1/4" X 90 SWIVEL ADAPTER
47	2		2315	9/16 O.R. TO 3/8P X 90 SWL.ADPT.
48				

REF# QTY IN KIT PART# DESCRIPTION  
 A4468-40 HPS4586 \* PART OF 6917 BOLT BAG

49					
50		1	* 765	1/4" BRASS BAR STREET ELL	
51	2		2780	1/4" BRASS BAR STREET ELL (FORGED)	
52		1	* 2318	1/4" BRASS BAR ELL	
53					
54					
55	2		1658	QUILL	
56					
57					
58					
59					
60					
61					
62					
63					
64					
65					
66					
67					
68					
69					
70					
71					
72		1	5704	SAFETY DECAL	
73	2		3042	GROMMET	
74	1		4477	SPLIT HOSE GROMMET	
75	3		3666	TIE WRAPS	
76					
77	1		90054	5/16 X 1-1/2 (NC) GR. 5 CAPSCREW	
78	4	1	* 90042	5/16 X 1 (NC) GR.5 CAPSCREW	
79	6	7	* 90360	5/16 LOCKWASHER	
80	7	3	* 90332	5/16 (NC) NUT	
81	4	3	* 90313	5/16 FLATWASHER	
82		6	* 90048	5/16 X 1-1/4 (NC) GR.5 CAPSCREW	
83		1	* 90067	5/16 X 2 (NC) GR.5 CAPSCREW	
84	1		90614	1/4 X 1-1/4 (NC) GR.5 CAPSCREW	
85	1		90359	1/4 LOCKWASHER	
86	1		90330	1/4 (NC) NUT	
87					
88		4	* 90361	3/8 LOCKWASHER	
89		2	* 90334	3/8 (NC) NUT	
90		1	* 90315	3/8 FLAT WASHER	
91					
92		1	* 90170	3/8 X 6 (NC) GR.5 CAPSCREW	
93		2	* 90570	3/8 X 5 (NC) GR.5 CAPSCREW	
94		1	* 90106	3/8 X 1-1/4 (NC) GR.5 CAPSCREW	

FASTENER TORQUE (FT-LB)			
DIAMETER- THREADS PER INCH	GRADE DESIGNATION		
	 GRADE 2	 GRADE 5	 GRADE 8
1/4 - 20	6	9	13
5/16 - 18	11	18	28
3/8 - 16	19	31	46
7/16 - 14	30	50	75
1/2 - 13	45	75	115
9/16 - 12	66	110	165
5/8 - 11	93	150	225
3/4 - 10	150	250	370
7/8 - 9	150	378	591
1 - 8	220	533	893

**1. CYLINDER AND CYLINDER HOSE ASSEMBLY**

- A. USING BENCH VISE TO HOLD LIFT CYLINDER (10), REMOVE CLOSURE FROM PORT. SCREW 90 DEGREE SWIVEL ADAPTOR (46) INTO PORT. PLACE LIFT CYLINDER WITH INSTALLED ADAPTOR BETWEEN EARS ON UNDERSIDE OF LIFT ARM AND LOWER HEADGEAR EARS. ATTACH CYLINDER TO EARS USING CLEVIS PINS (12) AND COTTER PINS (15).
- B. USING BENCH VISE TO HOLD 32" H.P. HOSE (20), INSTALL FEMALE HALF OF HOSE DISCONNECT ASSEMBLY (42) DIRECTLY TO HOSE. THEN, HOLDING 36" H.P. HOSE (21), INSTALL BRASS BAR STREET ELL (50) AND MALE HALF OF HOSE DISCONNECT ASSEMBLY (42) ON THE SAME HOSE END.
- C. USING BENCH VISE TO HOLD ANGLE CYLINDERS (11), REMOVE CLOSURES FROM PORTS AND SCREW BRASS FORGED STREET ELLS (51) INTO PORTS SO THAT ELLS ARE PARALLEL WITH CYLINDER AND POINT TOWARD LIVE END. INSTALL 32" H.P. HOSE WITH FEMALE DISCONNECT HALF TO DRIVER'S SIDE ANGLE CYLINDER STREET ELL. INSTALL OTHER H.P. HOSE WITH MALE DISCONNECT HALF TO PASSENGER SIDE ANGLE CYLINDER STREET ELLS. INSTALL ANGLE CYLINDERS TO "A" FRAME ON THEIR RESPECTIVE SIDES SO THAT ELLS ARE BETWEEN CYLINDERS AND "A" FRAME. SECURE CYLINDERS WITH ANCHOR PINS (13) AT PORT END AND RAM END. SECURE ANCHOR PINS WITH COTTER PINS (15).

**2. CONTROL HEAD AND CONTROL CABLES**

NOTE: DASH BRACKET, HARDWARE, DRILLING GUIDE AND MOUNTING INSTRUCTIONS WILL BE FOUND IN PECULIAR ATTACHING BOX.

- A. DRILL THREE 5/8" HOLES IN FIREWALL FOR CONTROL CABLES AND WIRING HARNESS USING DRILLING GUIDE AS A REFERENCE ONLY. BE SURE BOTH SIDES OF FIREWALL ARE CLEAR OF OBSTRUCTIONS BEFORE DRILLING. DRILL 1/2" HOLE IN UNDERSIDE OF DASH AS SHOWN IN DASH ILLUSTRATION.
- B. INSTALL DASH BRACKET AS PER DASH BRACKET INSTRUCTIONS.
- C. LOOSEN JAM NUTS ON CONTROL HEAD END OF CABLES (9) AND INSTALL INTO SLOTS IN CONTROL HEAD (8). (RAISE CABLE CENTERS IN BEGINNING OF LOWER SLOT). SNAP CABLE ENDS ONTO BALL STUDS AND TIGHTEN JAM NUTS TO SECURE CABLES TO CONTROL HEAD. REMOVE THE NUTS AND WASHERS FROM THE VALVE END OF THE CABLES. ROUTE THE CABLES OUT THROUGH THE FIREWALL UP TO THE TOP OF THE DRIVER SIDE FENDERWELL. ATTACH CONTROL HEAD TO DASH BRACKET AS PER DASH BRACKET INSTRUCTIONS. INSTALL RUBBER GROMMETS (73) AROUND CABLES WHERE THEY PASS THROUGH FIREWALL.

**3. VALVE AND VALVE PLATE**

- A. USING BENCH VISE TO HOLD CONTROL VALVE ASSEMBLY (2) REMOVE CLOSURES FROM VALVE PORTS. SCREW 90 DEGREE SWIVEL ADAPTOR UNIONS (47) INTO "IN" AND "OUT" PORTS. SCREW QUILL (55) INTO INSTALLED ADAPTOR IN "OUT" PORT. NOTE: VALVE FITTINGS ARE INSTALLED AS

DESCRIBED TO INSURE PROPER INSTALLATION. FIRST INDICATION OF INCORRECT INSTALLATION IS FAILURE OF PLOW TO LIFT ALTHOUGH PLOW WILL ANGLE.

B. ATTACH VALVE PLATE BRACE (30) TO VALVE PLATE (29) AS SHOWN ON ILLUSTRATION WITH A 5/16 X 1 CAPSCREW (78), LOCKWASHER (79) AND NUT (80). MOUNT VALVE TO VALVE PLATE USING TWO 1/4 X 1-1/4 CAPSCREWS, LOCKWASHERS AND NUTS FROM VALVE BAG. CONNECT CONTROL CABLES TO VALVE PLATE BEFORE FASTENING VALVE PLATE TO VEHICLE. BEGIN BY REINSTALLING JAM NUTS AND WASHERS ON CABLES. PLACE CONTROL CABLES IN RESPECTIVE SLOTS OF VALVE PLATE BULKHEAD WITH ONE NUT AND ONE WASHER ON EACH SIDE OF BULKHEAD. CENTER CABLES IN SLOTS SO THAT THEY ARE EXACTLY IN LINE WITH VALVE SPOOL CENTERS. ATTACH CABLE CLEVIS (3) TO CABLES USING SQUARE NUTS (4). SLIP CABLE CLEVISES OVER SPOOLS. INSTALL CLEVIS PIN (5) THROUGH CLEVIS AND SPOOL AND SECURE WITH PUSHNUT (6) ON CLEVIS PIN. TEMPORARILY ADJUST CABLES SO THAT CONTROL LEVER IS SOMEWHERE NEAR CENTERED IN CONTROL HEAD.

C. WITH CABLES ATTACHED, LOCATE VALVE PLATE ON TOP OF FENDERWELL SO THAT VALVE IS STRAIGHT AND LEVEL AND CABLES RUN AS STRAIGHT AS POSSIBLE WITH NO SHARP KINKS. USING THE TWO WIDEST SPACED HOLES ON THE FENDER SIDE OF VALVE PLATE AND THE HOLE IN THE FREE END OF VALVE PLATE BRACE AS GUIDES, DRILL THREE 11/32" HOLES. FASTEN PLATE AND BRACE WITH THREE 5/16 X 1 CAPSCREW (78), FLATWASHERS (81), LOCKWASHERS (79) AND NUTS (80).

D. WITH VALVE PLATE FASTENED TO INNER FENDER, READJUST CONTROL CABLES SO THAT CONTROL HEAD LEVER IS CENTERED BETWEEN BOTH ANGLE AND RAISE/LOWER POSITIONS. IF CABLE CLEVIS DOES NOT ALLOW ENOUGH ADJUSTMENT, REPOSITION CABLE AT VALVE PLATE BULKHEAD. AFTER CHECKING TO SEE THAT THE VALVE SPOOLS ARE IN THE CENTERED POSITION, TIGHTEN CABLE CLEVIS NUTS.

**CAUTION:** VALVE SPOOLS MUST BE FREE AND SELF CENTERING WHEN CABLES AND CONTROL HEAD ARE ATTACHED. FAILURE TO CENTER SPOOLS WILL RESTRICT FLUID FLOW THROUGH VALVE. THIS MAY CAUSE HYDRAULIC FLUID TO OVERHEAT RESULTING IN PUMP DAMAGE AND OR HYDRAULIC HOSE FAILURE. HOSE FAILURES CAN CAUSE ENGINE FIRES.

WHEN ADJUSTED, THE CONTROL LEVER MUST BE IN THE NEUTRAL POSITION TO ALLOW ENOUGH SPOOL TRAVEL EACH WAY FOR PROPER VALVE ACTUATION.

#### **4. DRIVE SHEAVE INSTALLATION**

A. REMOVE AND DISCARD CAPSCREWS AND WASHERS THAT FASTEN FAN TO WATER PUMP. REMOVE FAN.

B. INSTALL DRIVE SHEAVE (24) (WITH FACING PLATE TOWARDS FRONT OF VEHICLE) ONTO WATER PUMP SHAFT. REPLACE FAN AND FASTEN WITH FOUR 5/16 X 1-1/4 (NC) GR.5 CAPSCREWS(78) AND LOCKWASHERS(79). TORQUE THESE FASTENERS TO 18 FT. POUNDS.

#### **5. PUMP TANK AND PUMP BRACKET**

A. LOOSEN ALTERNATOR BELTS. REMOVE AND DISCARD BOTTOM BOLT HOLDING ALTERNATOR BRACKET TO WATER PUMP. REMOVE AND DISCARD BOLT TO THE LEFT OF OVAL CUT OUT IN ALTERNATOR BRACKET HOLDING BRACKET TO

CYLINDER HEAD. REMOVE AND DISCARD BOLT HOLDING ALTERNATOR BRACKET TO BOTTOM OF CYLINDER HEAD. ALIGN BOTTOM HOLE IN PUMP BRACKET (26) WITH HOLE IN BOTTOM OF ALTERNATOR BRACKET AND CYLINDER HEAD. FASTEN USING ONE 3/8 X 6 (NC) GR.5 CAPSCREW (92) AND LOCKWASHER (88). INSERT A 3/8 X 5 (NC) GR.5 CAPSCREW (93) WITH LOCKWASHER (88) INTO HOLE TO THE LEFT OF OVAL CUTOUT AND INTO CYLINDER HEAD. FASTEN BRACE ON PUMP BRACKET TO CYLINDER HEAD WITH ONE 3/8 X 1-1/4 (NC) GR.5 CAPSCREW (94) AND LOCKWASHER (88). REMOVE PIVOT BOLT FROM BOTTOM OF ALTERNATOR AND REPLACE WITH ONE 3/8 X 5 GR.5 CAPSCREW (93) AND 3/8 FLATWASHER (90). TIGHTEN CAPSCREW. PLACE UNIVERSAL BRACE TAB (38) OVER THREADS OF CAPSCREW AND FASTEN WITH ONE 3/8 LOCKWASHER (88) AND NUT(89).

B. HOLDING PUMP TANK (1) IN BENCH VISE, SCREW 1/4" BRASS BAR ELL (52) ONTO PRESSURE PORT OF PUMP AND SCREW QUILL (55) INTO RETURN PORT OF PUMP. INSTALL PUMP SHEAVE (25) ONTO PUMP SHAFT USING LOCKNUT AND KEY SUPPLIED WITH PUMP. REMOVE PUMP FROM VISE AND INSTALL SADDLE BRACKET (35) ON OVER FRONT OF PUMP. SECURE WITH A 5/16 X 2 GR. 5 CAPSCREW (82), LOCKWASHER (79) AND NUT (80). ATTACH SADDLE BRACKET AND PUMP TO PUMP BRACKET USING TWO 5/16 X 1-1/4 CAPSCREWS (82), FLATWASHER (81), LOCKWASHERS (79) AND NUTS (80).

C. INSTALL 55" V-BELT (23) ON OVER INSTALLED DRIVE AND PUMP SHEAVES. ALIGN SHEAVES AND TIGHTEN 2" SADDLE BRACKET FASTENER. ADJUST FOR PROPER TENSION BY PIVOTING SADDLE BRACKET ON DRIVERS SIDE MOUNTING BOLT. INSTALL REAR TANK STRAP (36) ON OVER REAR OF PUMP TANK. INSTALL ONE 5/16 NUT (80) AND FLATWASHER (81) ONTO UNIVERSAL BRACE ROD (37) AND INSERT BRACE ROD THROUGH PREVIOUSLY INSTALLED UNIVERSAL BRACE TAB. CONNECT BRACE ROD TO TANK STRAP WITH ONE 1/4 X 1-1/4 CAPSCREW (84), LOCKWASHER (85) AND NUT (86). FASTEN OTHER END OF BRACE ROD TO BRACE TAB WITH A 5/16 FLATWASHER (81), 5/16 LOCKWASHER (79) AND NUT (80). USE BRACE ROD TO ADJUST ALIGNMENT OF DRIVE AND PUMP SHEAVES. CHECK BELT FOR PROPER TENSION. TIGHTEN ALTERNATOR BELTS.

## **6. HYDRAULIC HOSE INSTALLATION**

A. ATTACH ONE END OF THE 60" H.P. HOSE (16) TO THE 1/4" SWIVEL ADAPTOR ON THE PUMP TANK AND PUSH ONE END OF THE 66" LP HOSE (17) ONTO THE QUILL ON PUMP TANK. ROUTE THESE HOSES TO THE CONTROL VALVE.

CAUTION: KEEP HOSES AWAY FROM HOT OR MOVING ENGINE COMPONENTS. FAILURE TO DO SO MAY CAUSE HOSE TO BURST RESULTING IN A POSSIBLE ENGINE FIRE.

PUSH L.P. HOSE ONTO QUILL AND SCREW H.P. HOSE INTO 90 DEGREE SWIVEL ADAPTOR. INSTALL 60" H.P. HOSE (18) TO LIFT CYLINDER PORT OF VALVE (SPOOL #1). INSTALL TWO 54" HOSES (19) TO ANGLE PORTS OF VALVE (SPOOL #2). ROUTE THE 60" AND 54" HOSES OUT THROUGH GRILL NEAR CENTER OF VEHICLE. ATTACH 60" HOSE TO PREVIOUSLY INSTALLED 90 DEGREE SWIVEL ADAPTOR ON LIFT CYLINDER.

## **7. DISCONNECT ASSEMBLY**

A. WITH DISCONNECT MOUNTING PLATE (39) HELD IN BENCH VISE, INSTALL

DISCONNECT HALVES AS SHOWN IN ILLUSTRATION. BULKHEAD ADAPTOR (44) AND MALE DISCONNECT HALF (42) GO IN BOTTOM HOLE. FEMALE DISCONNECT HALF (42) GOES IN TOP HOLE. SECURE BOTH WITH 7/8" SNAP RINGS (45). ATTACH MOUNTING PLATE TO BACK OF DRIVERS SIDE HEADGEAR POST WITH TWO 5/16 X 1 CAPSCREWS (78), LOCKWASHERS (79) AND NUTS (80). INSTALL DUST PLUGS (43) OVER ENDS OF HOSES ROUTED TO FRONT OF VEHICLE IN THE PREVIOUS STEP. CONNECT 54" RIGHT ANGLE HOSE (SPOOL #2, CYL. B) TO BACK OF FEMALE DISCONNECT INSTALLED IN TOP HOLE OF DISCONNECT BRACKET. CONNECT 54" LEFT ANGLE HOSE (SPOOL #2, CYL. A) TO BOTTOM (MALE) DISCONNECT. TIGHTEN BY HOLDING HOSES AND ROTATING THE DISCONNECT HALVES IN THE BRACKET.

## **B. OPERATIONS**

A. CHECK ALL FITTINGS AND FASTENERS FOR TIGHTNESS. SECURE HOSES WITH NYLON TIE WRAPS (75). PLACE SAFETY DECAL (72) ON DASH BESIDE CONTROL HEAD.

B. FILL RESERVOIR WITH TYPE "A" AUTOMATIC TRANSMISSION FLUID. START ENGINE, LIFT AND ANGLE BLADE. NOTE: IF BLADE ANGLES OPPOSITE FROM CONTROL LEVER POSITION, REVERSE THE TWO H.P. HOSE CONNECTIONS ON THE BACK OF THE DISCONNECT BRACKET. RAISE FRONT END OF VEHICLE UNTIL PLOW IS CLEAR OF GROUND WITH THE LIFT CYLINDER FULLY RETRACTED. CHECK RESERVOIR OIL LEVEL. ANGLE BLADE (WITH LIFT CYLINDER RETRACTED) TO REMOVE AIR FROM SYSTEM. RECHECK RESERVOIR OIL LEVEL.