

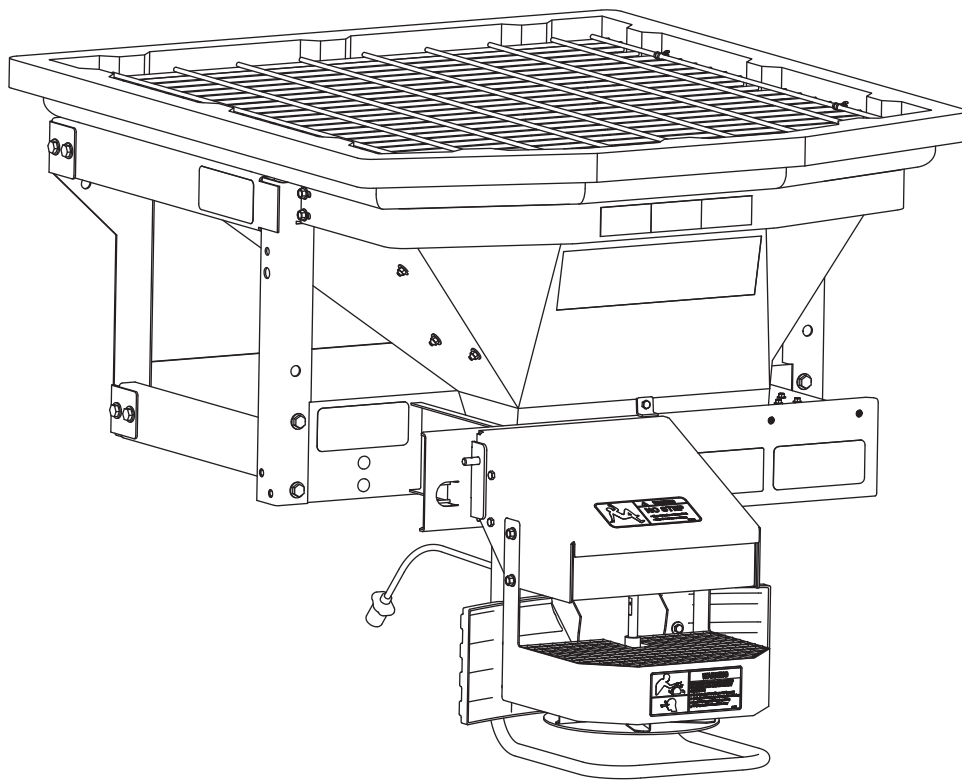

POLY-CASTER™ UTV Hopper Spreader

Installation Instructions



⚠ CAUTION

**Read this document before installing
or operating the spreader.**

These Installation Instructions are for FISHER® POLY-CASTER UTV hopper spreaders
with serial numbers beginning with 160901 and higher.

SAFETY

SAFETY DEFINITIONS

WARNING

Indicates a potentially hazardous situation that, if not avoided, could result in death or serious personal injury.

CAUTION

Indicates a potentially hazardous situation that, if not avoided, may result in minor or moderate injury. It may also be used to alert against unsafe practices.

NOTE: Indicates a situation or action that can lead to damage to your spreader and vehicle or other property. Other useful information can also be described.

WARNING/CAUTION LABELS

Become familiar with and inform users about the warning and caution labels on the spreader.

NOTE: If labels are missing or cannot be read, see your sales outlet.

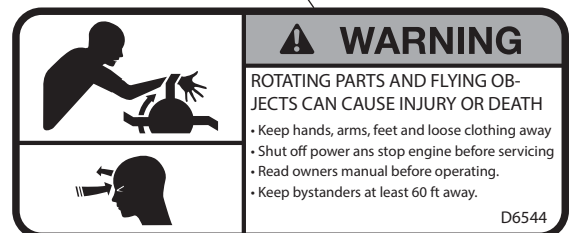
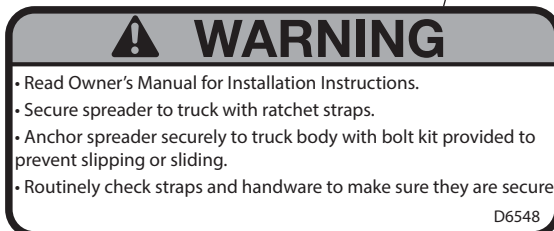
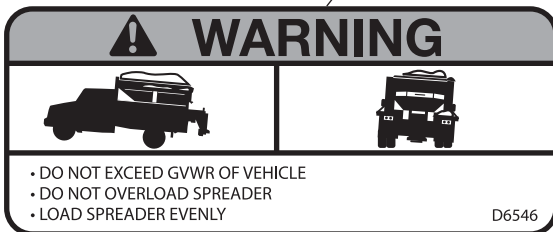
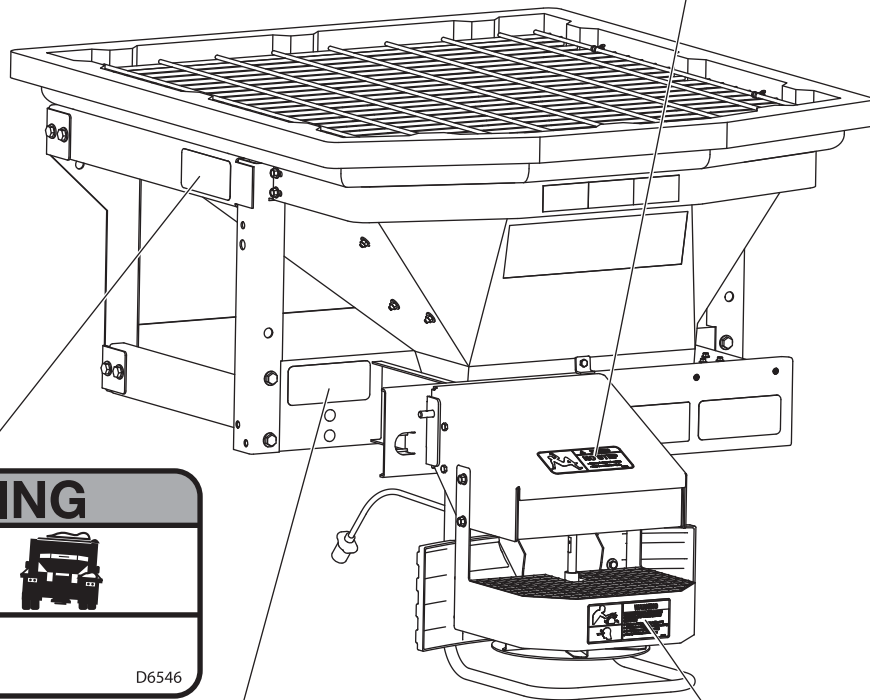
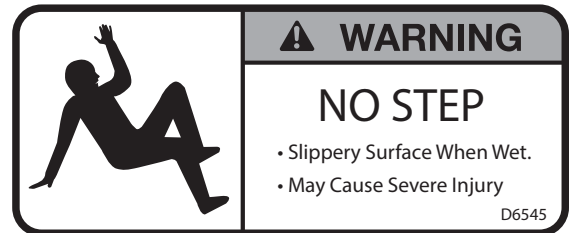

SAFETY

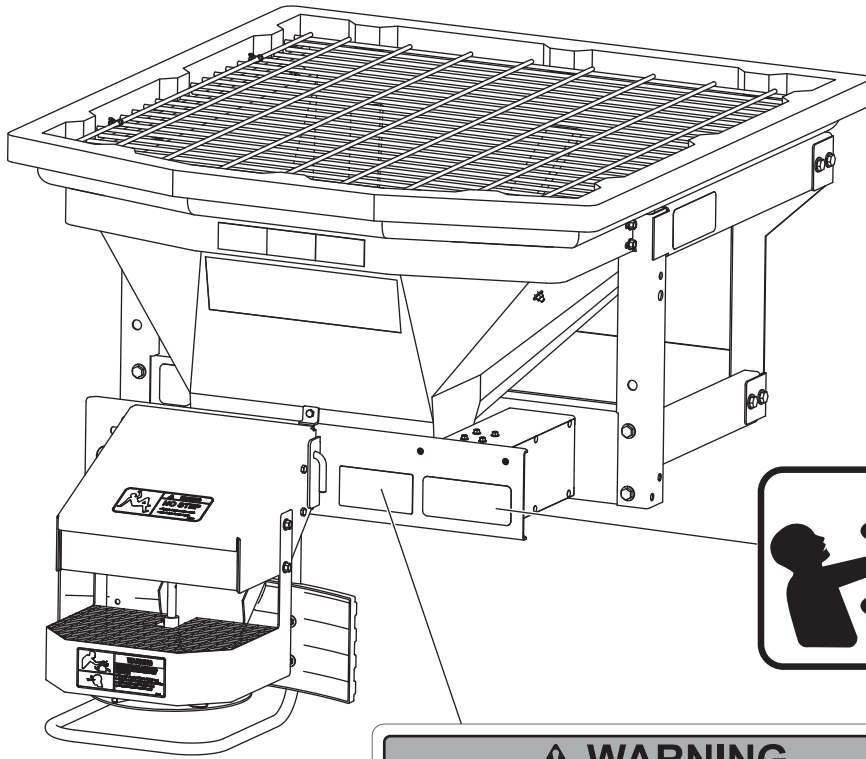



⚠ WARNING
 ROTATING AUGER CAN CAUSE
 SERIOUS INJURY OR DEATH

- Keep arms, hands, and loose clothing away from auger.
- Shut off control and unplug spreader before servicing.

D6335

⚠ WARNING

Vehicles <10,000 lb GVWR

Obstructing the visibility from the vehicle's rear camera could result in serious injury or damage. An auxiliary camera system shall be installed if the vehicle's rear camera is removed or blocked.

11100.00

SERIAL NUMBER LABEL

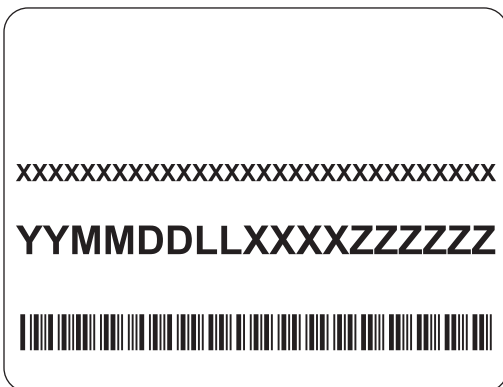

Code	Definition
YY	2-Digit Year
MM	2-Digit Month
DD	2-Digit Day
LL	2-Digit Location Code
XXXX	4-Digit Sequential Number
ZZZZZ	5- to 7-Digit Assembly PN

SAFETY

SAFETY PRECAUTIONS

Improper installation and operation could cause personal injury and/or equipment and property damage. Read and understand labels and the Owner's Manual before installing, operating, or making adjustments.

⚠ WARNING

- Driver to keep bystanders minimum of 25 feet away from operating spreader.
- Before working with the spreader, secure all loose-fitting clothing and unrestrained hair.
- Before operating the spreader, verify that all safety guards are in place.
- Before servicing the spreader, wait for conveyor, auger, and spinner to stop.
- Do not climb into or ride on spreader.

⚠ WARNING



Overloading could result in an accident or damage. Do not exceed GVWR of UTV. See Loading section to determine maximum volumes of spreading material.

⚠ WARNING

Vehicles <10,000 lb GVWR: Obstructing the visibility from the vehicle's rear camera could result in serious injury or damage. An auxiliary camera system shall be installed if the vehicle's rear camera is removed or blocked.

⚠ CAUTION

If rear directional, CHMSL light, or brake stoplights are obstructed by the spreader, the lights shall be relocated, or auxiliary directional or brake stoplights shall be installed.

⚠ CAUTION

- Do not operate a spreader in need of maintenance.
- Before operating the spreader, reassemble any parts or hardware removed for cleaning or adjusting.
- Before operating the spreader, remove materials such as cleaning rags, brushes, and hand tools from the spreader.
- Before operating the spreader, read the engine owner's manual, if so equipped.
- While operating the spreader, use auxiliary warning lights, except when prohibited by law.
- Tighten all fasteners according to the torque chart. Refer to torque chart for the recommended torque values.

⚠ CAUTION

Disconnect electric and/or hydraulic power and tag out if required before servicing or performing maintenance.

⚠ CAUTION



DO NOT leave unused material in hopper. Material can freeze or solidify, causing unit to not work properly. Empty and clean after each use.

NOTE: Lubricate grease fittings after each use. Use a good quality multipurpose grease.

FUSES

The electrical system contains several automotive-style fuses. If a problem should occur and fuse replacement is necessary, the replacement fuse must be of the same type and amperage rating as the original. Installing a fuse with a higher rating can damage the system and could start a fire.

SAFETY

PERSONAL SAFETY

- Remove ignition key and put the vehicle in PARK or in gear to prevent others from starting the vehicle during installation or service.
- Wear only snug-fitting clothing while working on your vehicle or spreader.
- Do not wear jewelry or a necktie, and secure long hair.
- Wear safety goggles to protect your eyes from battery acid, gasoline, dirt, and dust.
- Avoid touching hot surfaces such as the engine, radiator, hoses, and exhaust pipes.
- Always have a fire extinguisher rated BC handy, for flammable liquids and electrical fires

FIRE AND EXPLOSION

⚠ WARNING

Gasoline is highly flammable and gasoline vapor is explosive. Never smoke while working on vehicle. Keep all open flames away from gasoline tank and lines. Wipe up any spilled gasoline immediately.

Be careful when using gasoline. Do not use gasoline to clean parts. Store only in approved containers away from sources of heat or flame.

CELL PHONES

A driver's first responsibility is the safe operation of the vehicle. The most important thing you can do to prevent a crash is to avoid distractions and pay attention to the road. Wait until it is safe to operate Mobile Communication Equipment such as cell phones, text messaging devices, pagers, or two-way radios.

VENTILATION

⚠ WARNING

Vehicle exhaust contains lethal fumes. Breathing these fumes, even in low concentrations, can cause death. Never operate a vehicle in an enclosed area without venting exhaust to the outside.

BATTERY SAFETY

⚠ CAUTION









Batteries normally produce explosive gases which can cause personal injury. Therefore, do not allow flames, sparks, or lit tobacco to come near the battery. When charging or working near a battery, always cover your face and protect your eyes, and also provide ventilation.

- Batteries contain sulfuric acid, which burns skin, eyes, and clothing.
- Disconnect the battery before removing or replacing any electrical components.

TORQUE CHART

⚠ CAUTION

Read instructions before assembling. Fasteners should be finger tight until instructed to tighten according to the torque chart. Use standard methods and practices when attaching spreader, including proper personal protective safety equipment.

Recommended Fastener Torque Chart					
Inch Fasteners Grade 5 and Grade 8					
Size	Torque (ft-lb)		Size	Torque (ft-lb)	
	 Grade 5	 Grade 8		 Grade 5	 Grade 8
1/4-20	8.4	11.9	9/16-12	109	154
1/4-28	9.7	13.7	9/16-18	121	171
5/16-18	17.4	24.6	5/8-11	150	212
5/16-24	19.2	27.3	5/8-18	170	240
3/8-16	30.8	43.6	3/4-10	269	376
3/8-24	35.0	49.4	3/4-16	297	420
7/16-14	49.4	69.8	7/8-9	429	606
7/16-20	55.2	77.9	7/8-14	474	669
1/2-13	75.3	106.4	1-8	644	909
1/2-20	85.0	120.0	1-12	704	995
Metric Fasteners Class 8.8 and 10.9					
Size	Torque (ft-lb)		Size	Torque (ft-lb)	
	 Class 8.8	 Class 10.9		 Class 8.8	 Class 10.9
M6 x 1.00	7.7	11.1	M20 x 2.50	325	450
M8 x 1.25	19.5	26.9	M22 x 2.50	428	613
M10 x 1.50	38.5	53.3	M24 x 3.00	562	778
M12 x 1.75	67	93	M27 x 3.00	796	1139
M14 x 2.00	107	148	M30 x 3.50	1117	1545
M16 x 2.00	167	231	M33 x 3.50	1468	2101
M18 x 2.50	222	318	M36 x 4.00	1952	2701
These torque values apply to fasteners except those noted in the instructions.					

LOADING

These instructions cover vehicles that have been recommended for carrying the hopper spreader. Please see your local dealer for proper vehicle applications.

⚠ WARNING

Overloading could result in an accident or damage. Do not exceed GVWR of UTV.



⚠ CAUTION

Read and adhere to manufacturer's ice-control material package labeling, including Safety Data Sheet requirements.

⚠ CAUTION

Never use wet materials or materials with foreign debris with any of these spreaders. These units are designed to handle dry, clean, free-flowing material.

MATERIAL WEIGHTS

Material	Density		
	(lb/ft ³)	(lb/yd ³)	(kg/m ³)
Salt	80	2160	1282
Sand	100	2700	1602

Material densities are approximate and are based on dry, loose material. It is the responsibility of the operator to know the weight of the material to be spread and the vehicle carrying capacity.

DETERMINING VEHICLE PAYLOAD

1. Install the hopper spreader and optional equipment according to the instructions.
2. Install or attach any other equipment that will be on the vehicle while the hopper spreader will be in use (step bumper, trailer hitch, snowplow, etc.). Fill gas tanks.
3. Obtain the Gross Vehicle Weight Rating (GVWR) from the UTV manufacturer.
4. With the occupants in the truck for normal hopper spreader operation, weigh the vehicle to obtain gross vehicle weight (GVW).
5. Subtract the GVW from the GVWR to determine the available material payload.
6. Obtain the weight per cubic yard (lb/yd³) of the desired material. Divide the weight into the payload to determine the maximum volume of material that can be carried.
7. Fill the hopper with the calculated volume of material. Reweigh the vehicle with occupants and verify that the GVW is less than the vehicle's ratings.
8. Repeat Steps 6 and 7 for each type of material.

MOUNTING THE SPREADER

MOUNTING SPREADER

NOTE: Periodically throughout the snow and ice control season, verify that mounting devices are secure.

⚠ WARNING

Spreader shall be bolted to vehicle frame. Do not rely on the tie-down chains or straps alone to hold spreader in vehicle.

⚠ CAUTION

Before lifting, verify that hopper is empty of material. The lifting device must be able to support the spreader's weight.

1. Remove the tailgate from the UTV bed.
2. Load the spreader onto the UTV bed.
3. Assemble the chute to the deflector using the four 1/4" x 3/4" serrated flange cap screws and 1/4" locknuts in the supplied hardware kit.

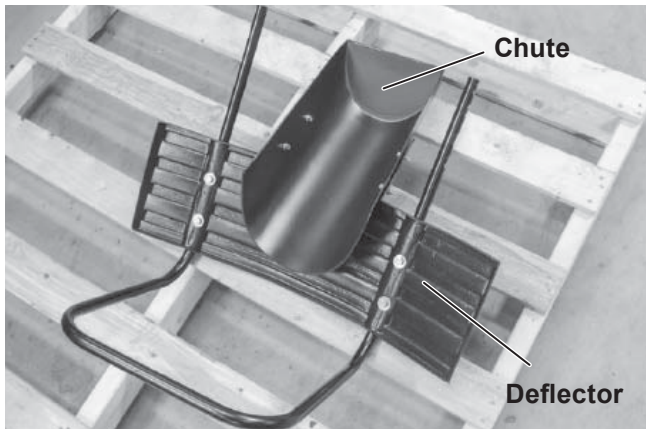

4. Install the chute/deflector assembly to the spinner assembly using the four 5/16" x 1-1/2" tapping screws and 5/16" locknuts in the supplied hardware kit to complete the drive assembly.

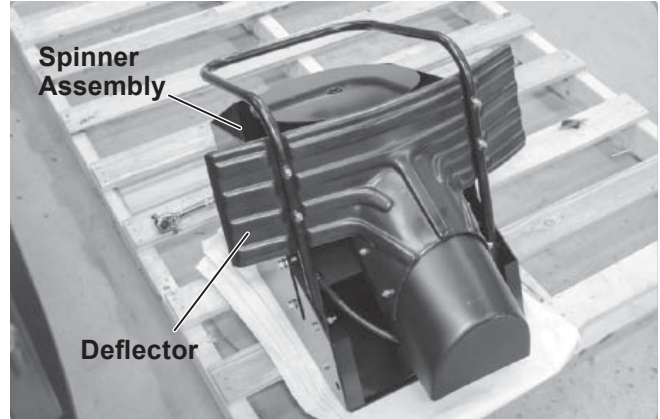

5. Mount the drive assembly to the spreader using the 1/2" x 17-5/8" bent pin and secure it with the 2-3/8" hairpin cotter. Ensure that the bent pin passes through the small center mounting tab on the auger drive enclosure.
6. Slide the spreader forward until the deflector/chute assembly makes contact with the vehicle. Then slide spreader back approximately 1" to allow proper clearance.
7. Once the spreader is positioned front to back in the vehicle bed, center it left to right.

MOUNTING THE SPREADER

- Looking at the inside corners of the spreader frame, you will notice four holes in the bottom of the frame. Using a paint pen or similar marking device, mark the hole locations on the vehicle bed.

If mounting holes cannot be drilled in the marked locations, install the optional mounting bars to the spreader frame using the supplied 1/2" x 1-1/2" carriage bolts and 1/2" locknuts. Use the existing holes in the mounting bars to mark drilling locations on the vehicle bed.

⚠ CAUTION

Before drilling holes, check to be sure that no vehicle wiring or other components could be damaged.

- Remove the spreader from the vehicle bed and drill 1/2" holes at the marked locations.

NOTE: Pay special attention when drilling or clamping dissimilar metals to aluminum bodies. Galvanic corrosion can occur if not handled properly. Contact vehicle manufacturer for recommended attachment practices.

- Install the spreader to the vehicle using the supplied 1/2" x 3" carriage bolts and 1/2" locknuts.
- Tighten all fasteners according to the torque chart.
- Install the four ratchet straps as shown below.

NOTE: It is important for safety that this strapping method be used as the standard mounting procedure.

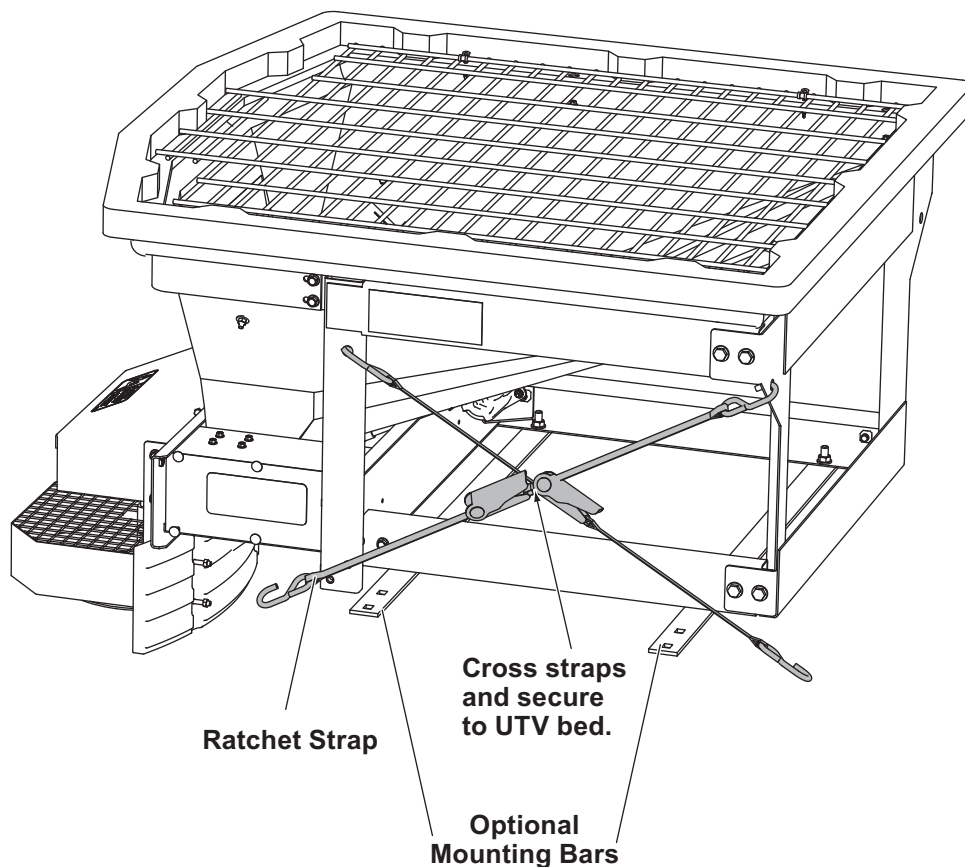

WIRING AND HARNESS INSTRUCTIONS

WIRING INSTRUCTIONS

1. Remove the vehicle floor pan and battery cover. If possible, tip up the bed and lock it in place.
2. Route the vehicle cable assembly along the vehicle frame from the rear of the vehicle to the front. Make sure that the path avoids any hot, sharp, or moving parts of the vehicle. Cable tie the harness to the frame holes and frame supports. Do not attach to fuel or brake lines.
3. Mount the rear plug to the bumper using the supplied bracket and fasteners. Position the plug toward the center of the bumper to reduce exposure to debris thrown up by the tires.
4. Install the dust cover and secure the pigtail to the harness mounting bracket using the existing fasteners.

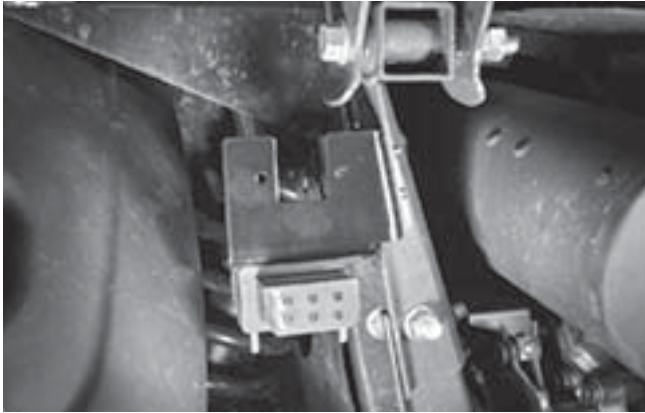

NOTE: Apply a small amount of dielectric grease to the plug. Try to mount the plug facing upward to help keep it tightly sealed.

5. Route the ignition wire and connect it. Consult UTV wiring diagram to locate a suitable ignition wire connection. Secure the harness from the rear to the battery using heavy-duty cable ties or frame clips along the frame and lighter duty cable ties everywhere else. Attach the relay assembly to the fender wall in a safe area.



⚠ CAUTION

Before drilling any holes, check both sides of the material for any wires, fuel lines, fuel tanks, etc., that may be damaged by drilling.

6. Pass the remaining harness into the cab under the floor pan. On the passenger's side of the centerline of the UTV, at the lower portion of the front cab where the floor mats meet the fire wall, choose a location for the harness to be routed into the cab. Before drilling, check the area on the other side of the fire wall to make sure that no wiring or control module could be damaged.

Drill and slot a 1" hole such that the harness can pass into the cab when the floor pan is reinstalled.

7. Connect power leads to the battery:

Red: POSITIVE (+)

Black: NEGATIVE (-)

Always connect to the primary battery if using a dual battery system. Secure loose loom to any other large or medium vehicle harness using medium-duty cable ties to secure the wiring harness.

WIRING AND HARNESS INSTRUCTIONS

Vehicle Control Harness Installation

Choose a mounting location where the control will be within easy reach of the vehicle operator and will not restrict access to vehicle controls or vehicle instrumentation. Do not mount the control in areas prohibited by the vehicle manufacturer for crash worthiness. See the vehicle's owner's manual or service manual for details.

NOTE: You may want to contact Technical Support before mounting the control if you prefer not to drill holes into the dashboard.

CAUTION

Before drilling into dash, verify no harnesses, relays, or other vehicle components can be damaged by drilling.

1. Install the control bracket in the mounting location using the provided tapping screws.
 2. Install the control to the control bracket using 1/4" x 1-1/2" cap screws, nylon washers, and steel washers.
 3. Connect the harness to the back of the control. Cable tie loose control harness securely below the floor pan. Do not mount close to any heater vents.
 4. Connect the spreader power cord to vehicle main power plug mounted at the rear of the vehicle.
5. Push the ON/OFF switch on the control to check for power. After power has been confirmed, push the ON/OFF switch again to turn the control OFF. The electrical portion of the installation is complete.

NOTE: Use dielectric grease on all electrical connections.

NOTE: In the off-season, remove the control and store in a cool, dry place. The interior summer temperatures could damage circuit board and void warranty.

NOTE: Do not modify harness length. Any modifications will void warranty.

- Apply dielectric grease to all external connections.
- Read lead labels before attaching to power source or ground.
- No other devices may be spliced into wiring harness.
- Any repairs to wiring harness must be done with heat-shrink butt connectors.

HARNES WIRING DIAGRAM

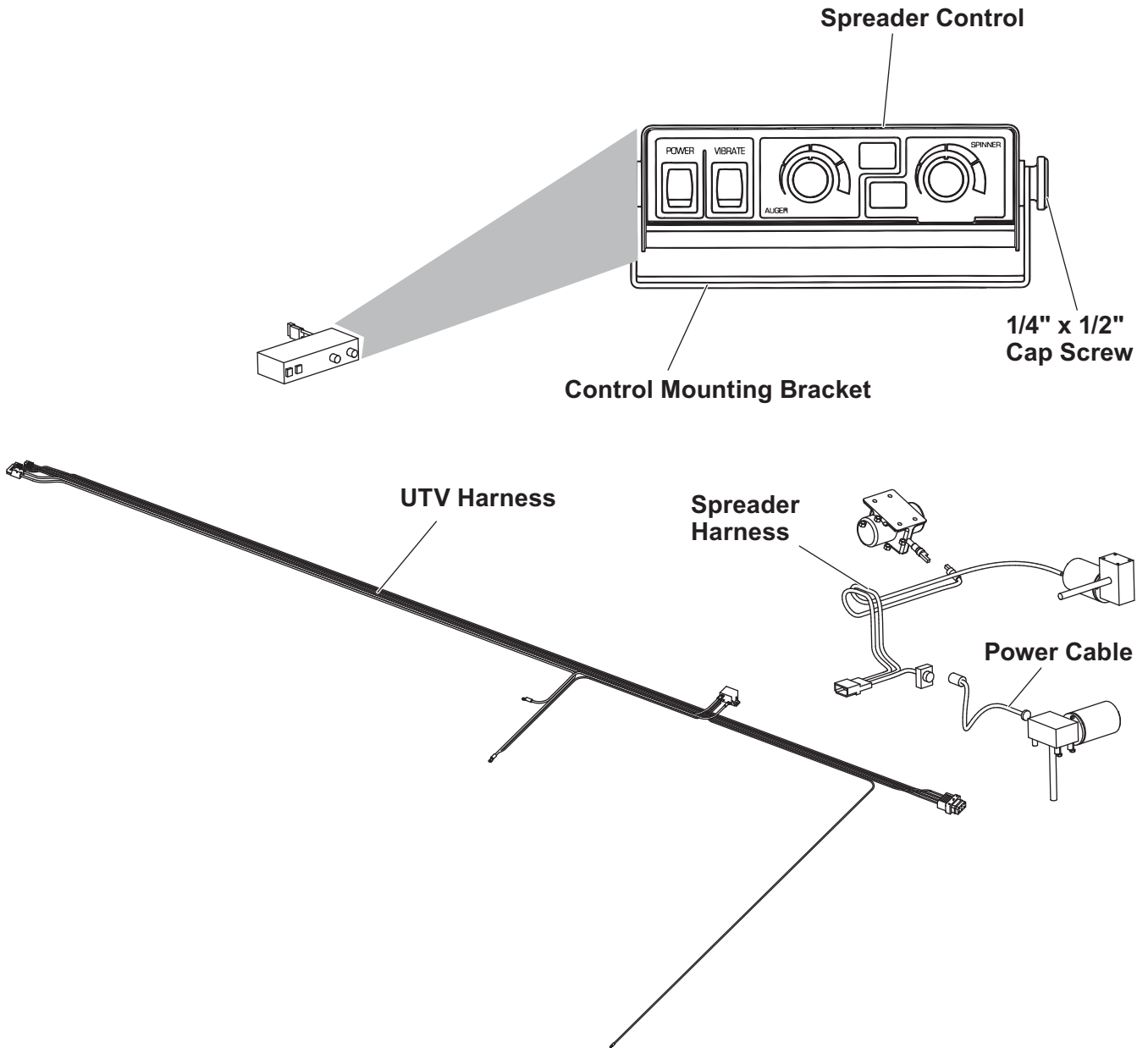

HARNESS DIAGRAM

Spreader Harness

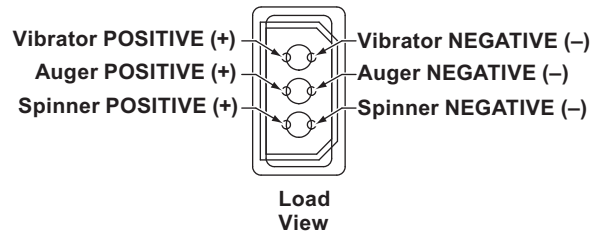
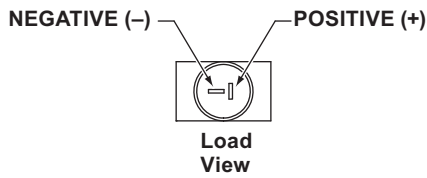
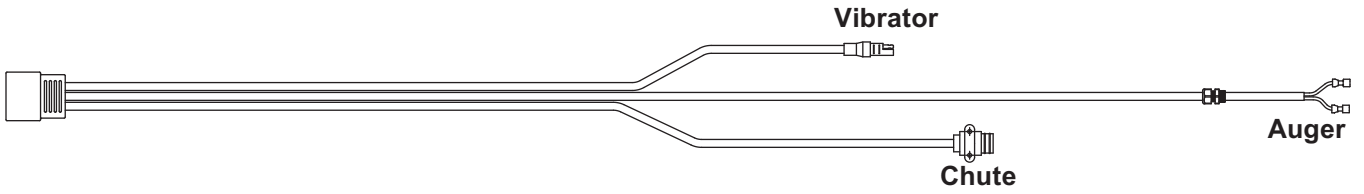

Control

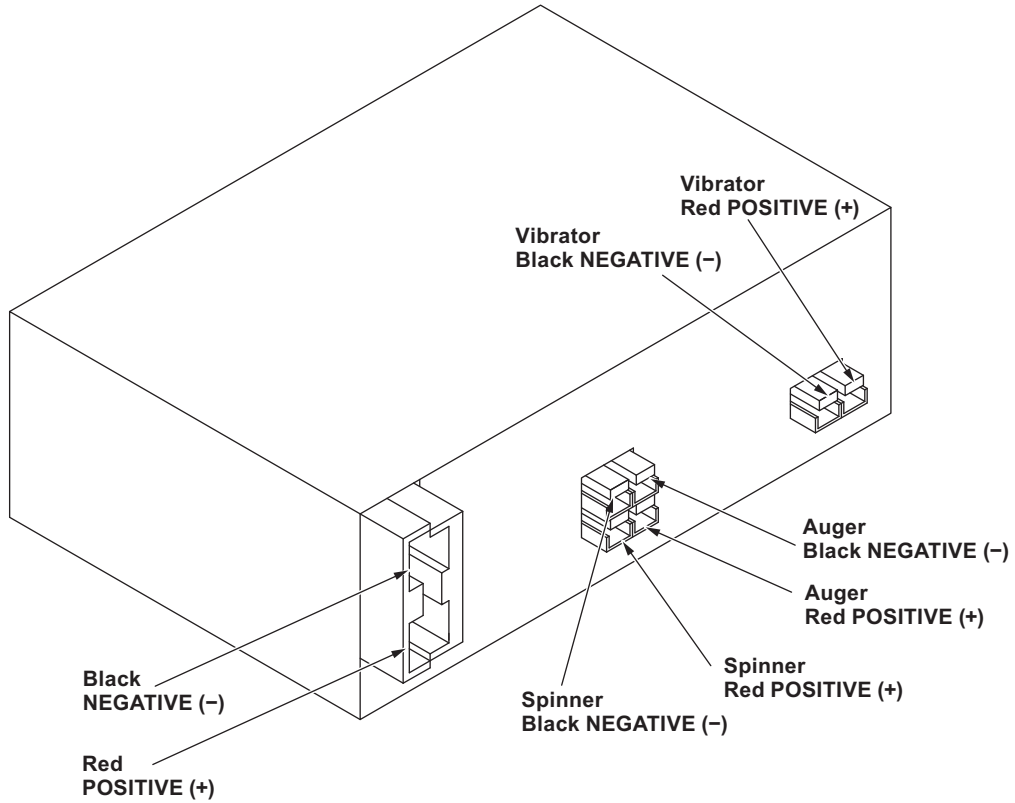

ELECTRICAL ROUTING

Under side of spinner
and trough.

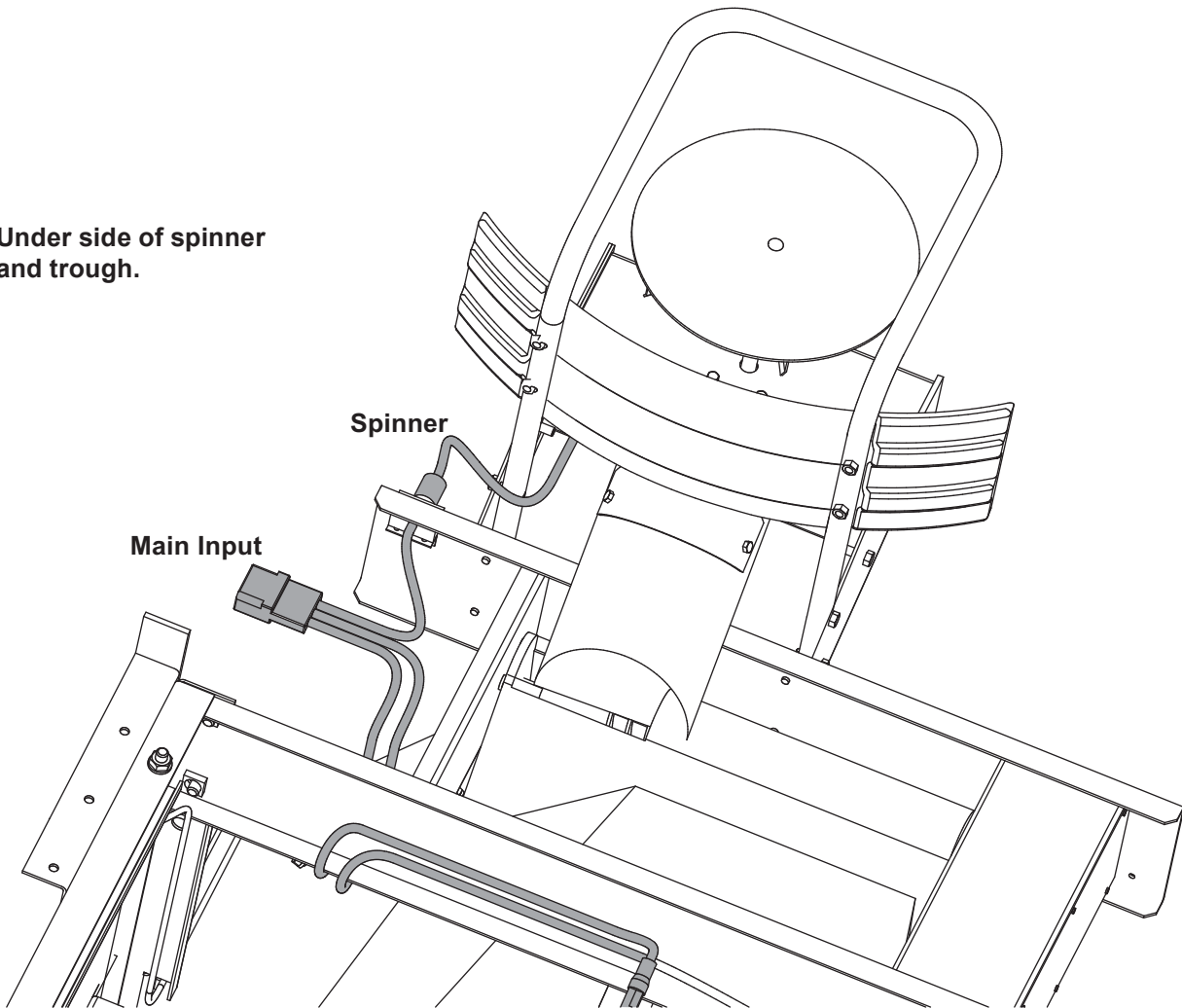

Auger and vibrator not shown.

FINAL ADJUSTMENTS

FINAL CHECKLIST

- Verify that dielectric grease is applied to all electrical connections.
- Verify that wire harnesses and battery cables are properly secured away from sharp, hot, or moving parts.
- Verify that the vehicle wiring harness has sufficient ground clearance when the spreader is removed from the UTV.



Fisher Engineering
50 Gordon Drive
Rockland, ME 04841-2139
www.fisherplows.com

A DIVISION OF FISHER, LLC

Copyright © 2020 Douglas Dynamics, LLC. All rights reserved. This material may not be reproduced or copied, in whole or in part, in any printed, mechanical, electronic, film, or other distribution and storage media, without the written consent of Fisher Engineering. Authorization to photocopy items for internal or personal use by Fisher Engineering outlets or spreader owner is granted.

Fisher Engineering reserves the right under its product improvement policy to change construction or design details and furnish equipment when so altered without reference to illustrations or specifications used. Fisher Engineering or the vehicle manufacturer may require or recommend optional equipment for spreaders. Do not exceed vehicle ratings with a spreader. Fisher Engineering offers a limited warranty for all spreaders and accessories. See separately printed page for this important information. The following are registered (®) or unregistered (™) trademarks of Douglas Dynamics, LLC: FISHER®, POLY-CASTER™.

Printed in U.S.A.