



MOUNT KIT

John Deere Tractor 40XXR Series

2018—__

Installation Instructions

▲ CAUTION

Read this document before installing the snowplow.

▲ CAUTION

See your FISHER® outlet/website for specific vehicle application recommendations before installation. The eMatch tool has specific vehicle and snowplow requirements.

SAFETY DEFINITIONS

⚠ WARNING

Indicates a potentially hazardous situation that, if not avoided, could result in death or serious personal injury.

⚠ CAUTION

Indicates a potentially hazardous situation that, if not avoided, may result in minor or moderate injury. It may also be used to alert against unsafe practices.

NOTE: Indicates a situation or action that can lead to damage to your snowplow and vehicle or other property. Other useful information can also be described.

Mount Caution Label

⚠ CAUTION

Loader **MUST** be removed before attaching snowplow.

Failure to do so may overload front axle or cause equipment interference, damaging tractor or snowplow.

77506.00

WARNING/CAUTION & INSTRUCTION LABELS

Become familiar with and inform users about the warning labels on the back of the blade and the instruction label on the headgear.

NOTE: If labels are missing or cannot be read, see your sales outlet.

Warning/Caution Label

⚠ WARNING



Lower blade when vehicle is parked.

Do not exceed GVWR or GAWR including blade and ballast.

⚠ CAUTION



Read Owner's Manual before operating or servicing snowplow.

Transport speed should not exceed 45 mph (72 km/h). Further reduce speed under adverse travel conditions.

Plowing speed should not exceed 10 mph (16 km/h).

See your sales outlet/website for specific vehicle application recommendations.

59900.13

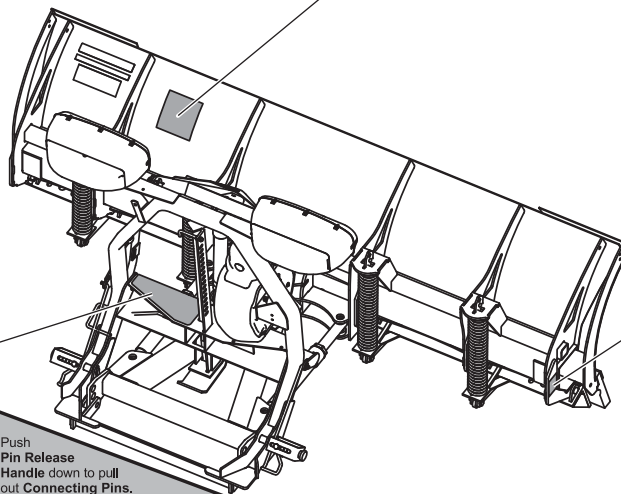

Multiple Pinch Points Label

⚠ WARNING



Multiple Pinch Points

XLS™ Blades Only (both sides)

Instruction Label

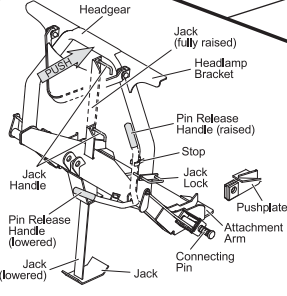

1. Push **Pin Release Handle** down to pull out **Connecting Pins**.
2. Drive vehicle slowly to engage **Pushplates** into **Attachment Arms**.
3. Stand in front of blade. Fully raise **Pin Release Handle** to release **Connecting Pins**.
4. Push **Headgear** toward vehicle to allow **Connecting Pins** to fully engage **Pushplates**. If unable to push **Headgear** from in front of blade, stand in front of **Headgear** on driver side and push **Headlamp Bracket**.
5. Pull out **Jack Lock**. Push **Pin Release Handle** into **Stop**.
6. While holding **Jack Lock** out, use **Jack Handle** to raise **Jack** fully. Release **Jack Lock**.
7. Attach all electrical connectors.

Read Owner's Manual for complete instructions.

1. Place control in Lower/Float to put blade down.
2. Pull and hold **Jack Lock** out. **Jack** will drop to ground. Then pull **Pin Release Handle** away from **Stop** and **Jack Lock**. Release **Jack Lock**. Verify that **Jack** is locked by trying to lift **Jack**.

3. Stand in front of blade. While pushing **Headgear** toward vehicle with left hand, push **Pin Release Handle** down to disengage **Connecting Pins**. Make sure **Connecting Pins** are fully retracted. If unable to push **Headgear** from in front of blade, stand in front of **Headgear** on driver side and push **Headlamp Bracket**.
4. Detach all electrical connectors.

U.S. patents 6,408,549; 6,526,677; 6,711,937; 6,900,757; 6,944,976; 7,400,056; 7,430,821; 7,691,334; 7,737,076; 7,797,859; 9,200,416; 9,822,963. CAN patents 2,354,267; 2,356,036; 2,632,102; 2,639,052; and other patents pending.

ATTACH

DETACH

SAFETY PRECAUTIONS

Improper installation and operation could cause personal injury and/or equipment and property damage. Read and understand labels and the Owner's Manual before installing, operating, or making adjustments.

⚠ WARNING

Lower the blade when vehicle is parked. Temperature changes could change hydraulic pressure, causing the blade to drop unexpectedly or damaging hydraulic components. Failure to do this could result in serious personal injury.

⚠ WARNING

The driver shall keep bystanders clear of the blade when it is being raised, lowered, or angled. Do not stand between vehicle and blade or within 8 feet of a moving blade. A moving or falling blade could cause personal injury.

⚠ WARNING

Keep hands and feet clear of the blade and A-frame when mounting or removing the snowplow. Moving or falling assemblies could cause personal injury.

⚠ WARNING

To prevent accidental movement of the blade, always turn the control OFF whenever the snowplow is not in use. The power indicator light will turn OFF.

⚠ WARNING

Remove blade assembly before placing vehicle on hoist.

⚠ CAUTION

Refer to the eMatch tool for minimum vehicle recommendations and ballast requirements.

PERSONAL SAFETY

- Remove ignition key and set the vehicle parking brake to prevent others from starting the vehicle during installation or service.
- Wear only snug-fitting clothing while working on your vehicle or snowplow.
- Do not wear jewelry or a necktie, and secure long hair.
- Wear safety goggles to protect your eyes from battery acid, gasoline, dirt, and dust.
- Avoid touching hot surfaces such as the engine, radiator, hoses, and exhaust pipes.
- Always have a fire extinguisher rated BC handy, for flammable liquids and electrical fires.

FIRE AND EXPLOSION

⚠ WARNING

Gasoline is highly flammable and gasoline vapor is explosive. Never smoke while working on vehicle. Keep all open flames away from gasoline tank and lines. Wipe up any spilled gasoline immediately.

Be careful when using gasoline. Do not use gasoline to clean parts. Store only in approved containers away from sources of heat or flame.

CELL PHONES

A driver's first responsibility is the safe operation of the vehicle. The most important thing you can do to prevent a crash is to avoid distractions and pay attention to the road. Wait until it is safe to operate Mobile Communication Equipment such as cell phones, text messaging devices, pagers, or two-way radios.

VENTILATION

⚠ WARNING

Vehicle exhaust contains lethal fumes. Breathing these fumes, even in low concentrations, can cause death. Never operate a vehicle in an enclosed area without venting exhaust to the outside.

NOISE

Airborne noise emission during use is below 70 dB(A) for the snowplow operator.









VIBRATION

Operating snowplow vibration does not exceed 2.5 m/s² to the hand-arm or 0.5 m/s² to the whole body.

TORQUE CHART

⚠ CAUTION

Read instructions before assembling. Fasteners should be finger tight until instructed to tighten according to the torque chart. Use standard methods and practices when attaching snowplow, including proper personal protective safety equipment.

Recommended Fastener Torque Chart					
Inch Fasteners Grade 5 and Grade 8					
Size	Torque (ft-lb)		Size	Torque (ft-lb)	
	 Grade 5	 Grade 8		 Grade 5	 Grade 8
1/4-20	8.4	11.9	9/16-12	109	154
1/4-28	9.7	13.7	9/16-18	121	171
5/16-18	17.4	24.6	5/8-11	150	212
5/16-24	19.2	27.3	5/8-18	170	240
3/8-16	30.8	43.6	3/4-10	269	376
3/8-24	35.0	49.4	3/4-16	297	420
7/16-14	49.4	69.8	7/8-9	429	606
7/16-20	55.2	77.9	7/8-14	474	669
1/2-13	75.3	106.4	1-8	644	909
1/2-20	85.0	120.0	1-12	704	995
Metric Fasteners Class 8.8 and 10.9					
Size	Torque (ft-lb)		Size	Torque (ft-lb)	
	 Class 8.8	 Class 10.9		 Class 8.8	 Class 10.9
M6 x 1.00	7.7	11.1	M20 x 2.50	325	450
M8 x 1.25	19.5	26.9	M22 x 2.50	428	613
M10 x 1.50	38.5	53.3	M24 x 3.00	562	778
M12 x 1.75	67	93	M27 x 3.00	796	1139
M14 x 2.00	107	148	M30 x 3.50	1117	1545
M16 x 2.00	167	231	M33 x 3.50	1468	2101
M18 x 2.50	222	318	M36 x 4.00	1952	2701
These torque values apply to fasteners except those noted in the instructions.					

INSTALLATION INSTRUCTIONS

NOTE: For easier assembly and installation, vehicle and all snowplow components should be on a smooth, level, hard surface, such as concrete.

NOTE: The mount kit is designed to remain on the tractor while retaining use of the loader assembly. After installation of the mount, care must be taken when attaching and detaching the loader assembly. If the loader parking stand does not clear the mount, lower the loader assembly until the parking stand touches the ground, then slowly raise the loader again to reattach to the tractor.

1. Detach the loader and remove the brush guard. Retain the fasteners for reinstallation if the mount is removed in the future.

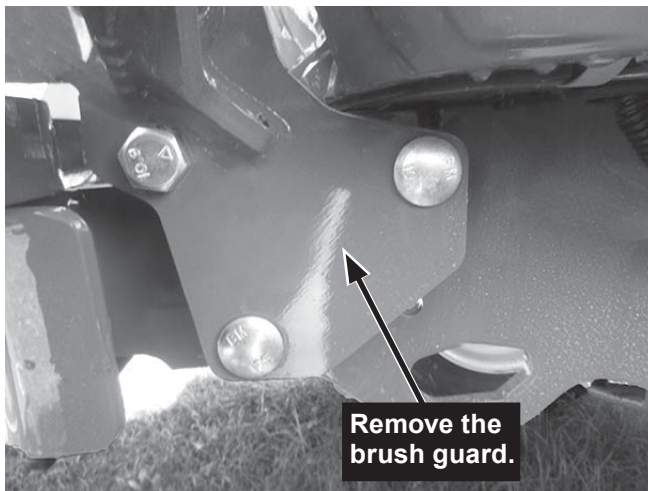

2. Place the push beam against the front of the tractor as shown. Install a 1/2" x 1-1/2" cap screw through each of the three holes shown. Secure the fasteners with 1/2" washers and 1/2" locknuts. Hand tighten the fasteners.

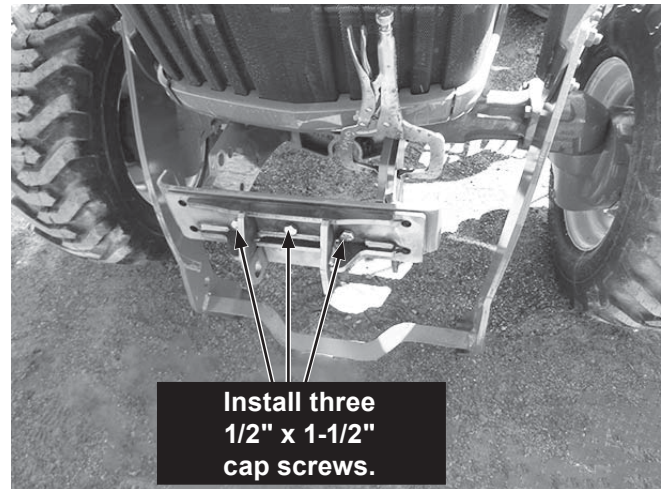

3. Place the left thrust arm against the left frame rail of the tractor as shown. Place a 5/8" washer on a 5/8" x 3" cap screw, and place 1/2" washers on two 1/2" x 2-1/2" cap screws. Install the fasteners in the locations shown. Hand tighten the fasteners.

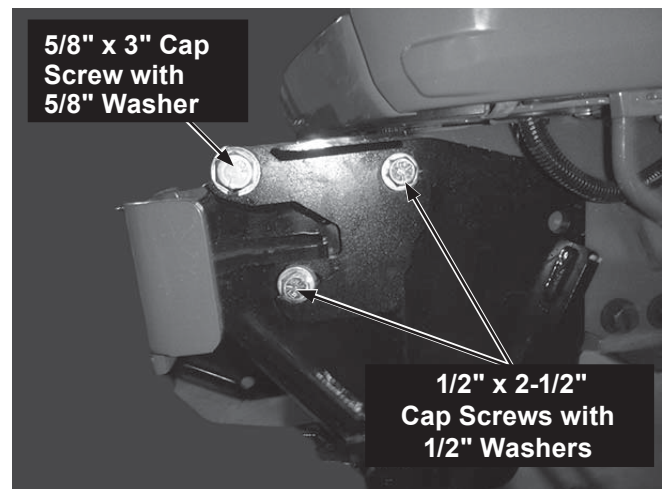

NOTE: If desired, the brush guard may be reinstalled over the thrust arms by using the alternate set of fasteners shown in the Parts List.

4. Repeat Step 3 on the right side of the vehicle.
5. Install four 1/2" x 2" cap screws through the outer holes of the push beam as shown. Secure to the left and right thrust arms using a 1/2" washer and 1/2" locknut on each cap screw.

6. Install the cross bar between the left and right thrust arms using four 1/2" x 1-1/4" cap screws. Secure with 1/2" locknuts.
7. Tighten all fasteners according to the torque chart. Install the mount assembly using the clevis pins and linchpins provided. Check that the mount assembly is level. Loosen fasteners and make adjustments as necessary. Be sure to re-torque all fasteners after adjustments are made.

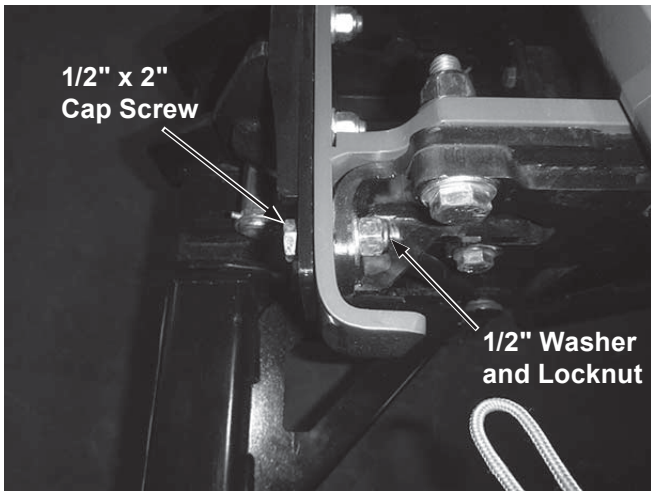
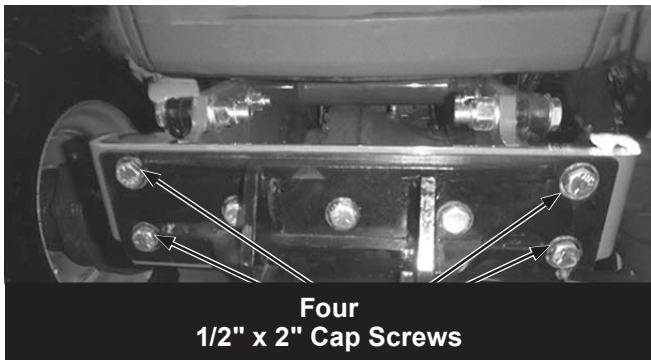

⚠ CAUTION

Use caution not to pinch, cut or drill through any wires or hoses running along the frame rails.

- Using the rear hole of the left thrust arm as a guide, drill a hole through the frame of the tractor big enough to install a 5/8" cap screw.

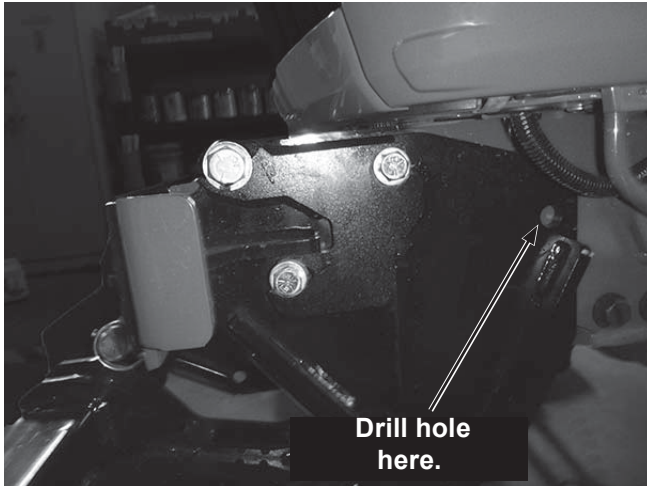

Repeat on the opposite side.

- Install a 5/8" x 2" cap screw through each of the holes drilled in Step 8. Secure the cap screws with 5/8" washers and 5/8" locknuts. Tighten fasteners according to the torque chart.

NOTE: After five to ten hours of snowplow usage, retorque all mount assembly fasteners.



Fisher Engineering
50 Gordon Drive
Rockland, ME 04841-2139
www.fisherplows.com

A DIVISION OF FISHER, LLC

Fisher Engineering reserves the right under its product improvement policy to change construction or design details and furnish equipment when so altered without reference to illustrations or specifications used. Fisher Engineering or the vehicle manufacturer may require or recommend optional equipment for snow removal. Do not exceed vehicle ratings with a snowplow. Fisher Engineering offers a limited warranty for all snowplows and accessories. See separately printed page for this important information. The following are registered (®) or unregistered (™) trademarks of Douglas Dynamics, LLC: FISHER®, Minute Mount® 2.

Printed in U.S.A.