

Strobe Light Kit

Stainless Steel Hopper Spreaders

PARTS LIST

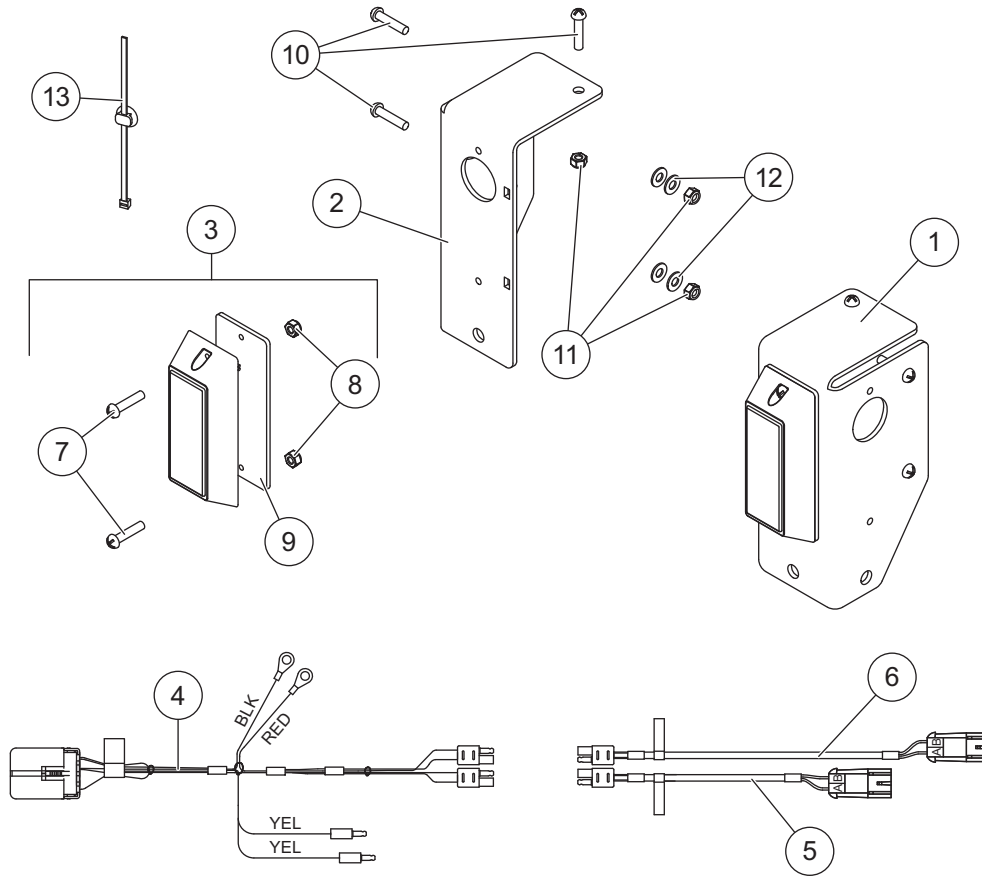

99494 Strobe Light Kit							
Item	Part	Qty	Description	Item	Part	Qty	Description
1	99495	1	Strobe Light Bracket – PS	5	78378	1	Harness Assembly – 56"
2	99496	1	Strobe Light Bracket – DS	6	78386	1	Harness Assembly – 72"
3	78379	2	Strobe Light – LED	ns	99103	1	Bolt Bag
4	78381	1	Harness Assembly w/Relay & Fuse				
Item 3				78379 Strobe Light – LED			
7		2	#6-32 x 5/8 Machine Screw SS	9		1	Strobe Light Gasket
8		2	#6-32 Locknut SS				
				99103 Bolt Bag			
10		6	#10-32 x 1 Machine Screw SS	13		8	Fir Tree Mount w/Cable Tie
11		6	#10-32 Hex Locknut GB SS	ns		6	Cable Tie – 15.35"
12		8	#10 Flat Washer SS				
		ns = not shown				G = Grade	
						SS = Stainless Steel	

INSTALLATION INSTRUCTIONS

⚠ WARNING

Do not exceed GVWR or GAWR ratings as found on the driver-side vehicle door cornerpost.

⚠ CAUTION

Read this document before installing the strobe lights.

⚠ CAUTION

Use standard methods and practices when attaching spreader and installing accessories, including proper personal protective safety equipment.

Spreaders with Gasoline Engine

The Accessory Bracket & Harness Kit – Gas must be installed before the strobe lights and brackets can be installed.

Spreaders with Hydraulic Drive

The Accessory Enclosure & Harness Kit – Hydraulic must be installed before the strobe lights and brackets can be installed, as shown on page 4.

Install Brackets and Lights

1. Park the vehicle on a smooth, level, hard surface, such as concrete. Turn the vehicle ignition to the "OFF" position and remove the key.
2. Position the passenger-side strobe light bracket at the rear of the hopper as shown, allowing a 2" gap between the bracket and the hopper.

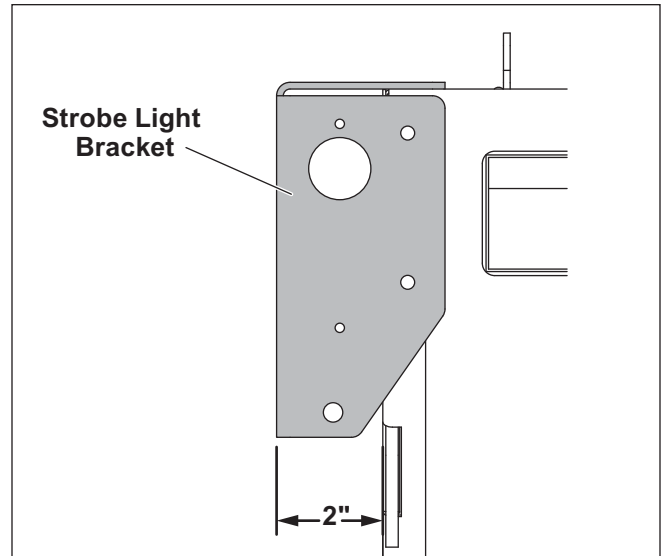

⚠ CAUTION

Before drilling holes, check to be sure that no vehicle wiring or other components could be damaged.

3. Using the bracket as a template, mark the location of the three bracket mounting holes on the hopper. Drill pilot holes using a #3 or 7/32" drill bit.

For 0.35 yd³ and 0.7 yd³ hopper spreaders:

Remove the carriage bolts from the corner. Use all three available holes to install the bracket.

4. Install the bracket to the hopper using the supplied #10 hardware.
5. The flat washers can be used to make up space between the bracket and the hopper side so the bracket fits squarely on the hopper.
6. Repeat Steps 2–4 for the driver-side bracket.

7. Feed the electrical connector and leads from one of the LED strobe lights through the large hole in one of the brackets. Install the LED light and gasket to the bracket using the supplied #6 x 5/8" machine screws and #6 locknuts. Repeat with the other LED light and gasket.

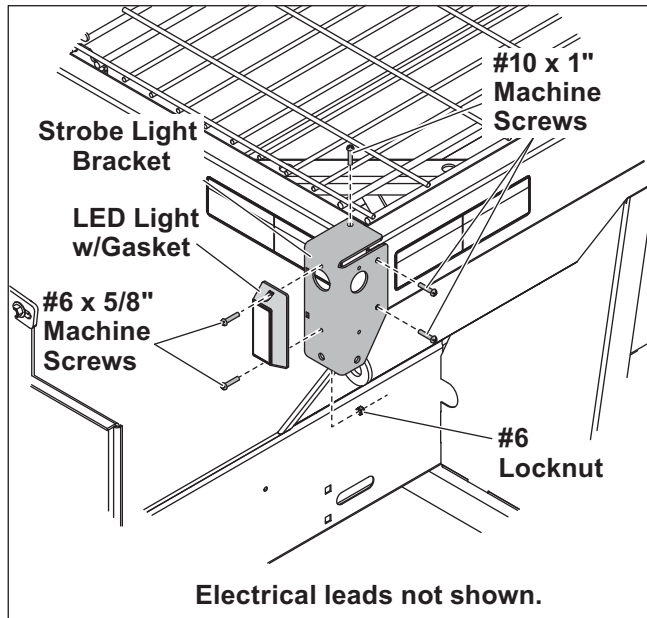

Install Harness, Relay, and Fuse Assembly

If an accessory work light has been installed previously, the strobe light harness can be secured to the existing work light harness. Skip to Step 3.

If no work light harness is already installed, use the supplied fir tree mounts and cable ties to secure the strobe light harness between the lights and the electrical enclosure, as described below.

1. Drill 1/4" holes along both sides of the hopper as shown. Push a fir tree mount into each hole.

NOTE: The 0.7 yd³ hopper spreader has knockouts in the end cap for use instead of drilled holes.

Electric Models

Fir Tree Mount and Cable Ties

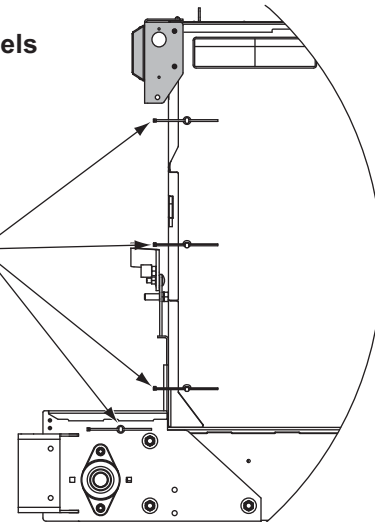

Gas/Hydraulic Models

Fir Tree Mount and Cable Ties

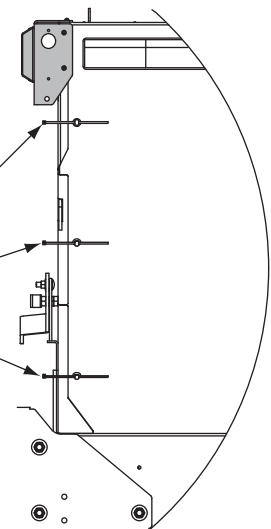

2. Secure the strobe light harness to the hopper with the fir tree mount cable ties.

3. The strobe light kit contains two harness assemblies: 56" and 72". Determine your harness routing and connect the appropriate harness to each strobe light.
4. **Electric and Hydraulic Spreaders:** Cut holes in two of the break-thru plugs (one on each side of the electrical enclosure) and feed the harnesses into the enclosure. The holes should be sized to form a tight seal around the harnesses.

Gas Spreaders: Route the harnesses into the engine enclosure from the passenger's side, just forward of the engine mounting plate, taking care to position the harnesses where the engine cover will not contact them when the cover is closed.

5. Mount the relay/fuse assembly to the relay/fuse assembly bracket by pushing the connector clip on the back of the assembly into one of the holes in the bracket. Secure the relay/fuse assembly to the bracket by running a cable tie through the slots in the bracket and around the relay/fuse assembly.

Gas Spreaders: For best fit, install the strobe light relay/fuse assembly in the farthest right or second from right position on the assembly bracket.

Electric Spreader – Full Size

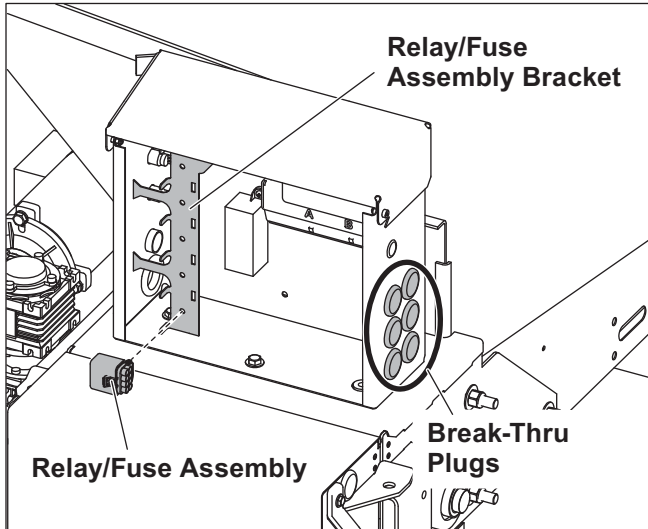

Hydraulic Spreader – Full Size

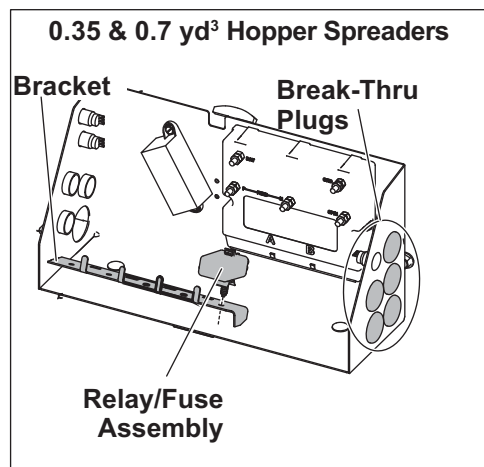
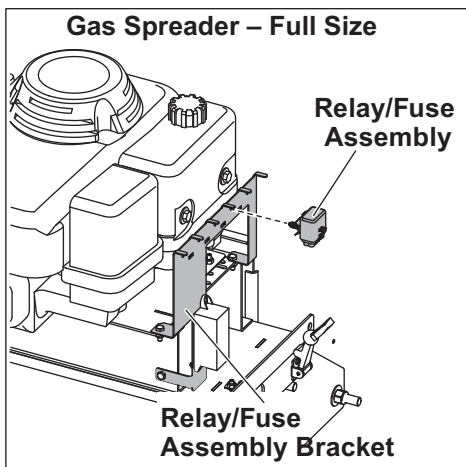
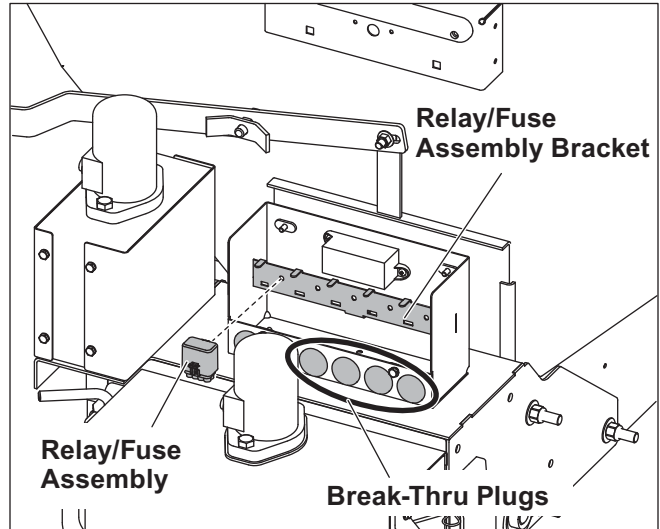

Electrical enclosure covers not shown.

Electrical Connections

1. Plug the relay/fuse harness 10-pin connector into the relay/fuse assembly.
2. Plug the strobe light harness connectors into the matching connectors on the relay/fuse assembly harness.
3. Remove the cover from the isolated stud block and connect the relay/fuse assembly harness red wire to the POSITIVE (+) terminal and the black wire to the NEGATIVE (-) terminal. Replace the cover, being careful not to pinch any wires. On spreader

installations with multiple accessories, it may be necessary to notch the sides of the isolated stud block cover to accommodate all the wires.

4. **Electric Spreaders:** Connect the single-pin terminal on the relay/fuse assembly harness (yellow wire) to the white wire coming from port A of the spreader module.

Gas/Hydraulic Spreaders: Connect the single-pin terminal on the relay/fuse assembly harness (yellow wire) to the white wire coming from the previously installed hopper accessory cable assembly.

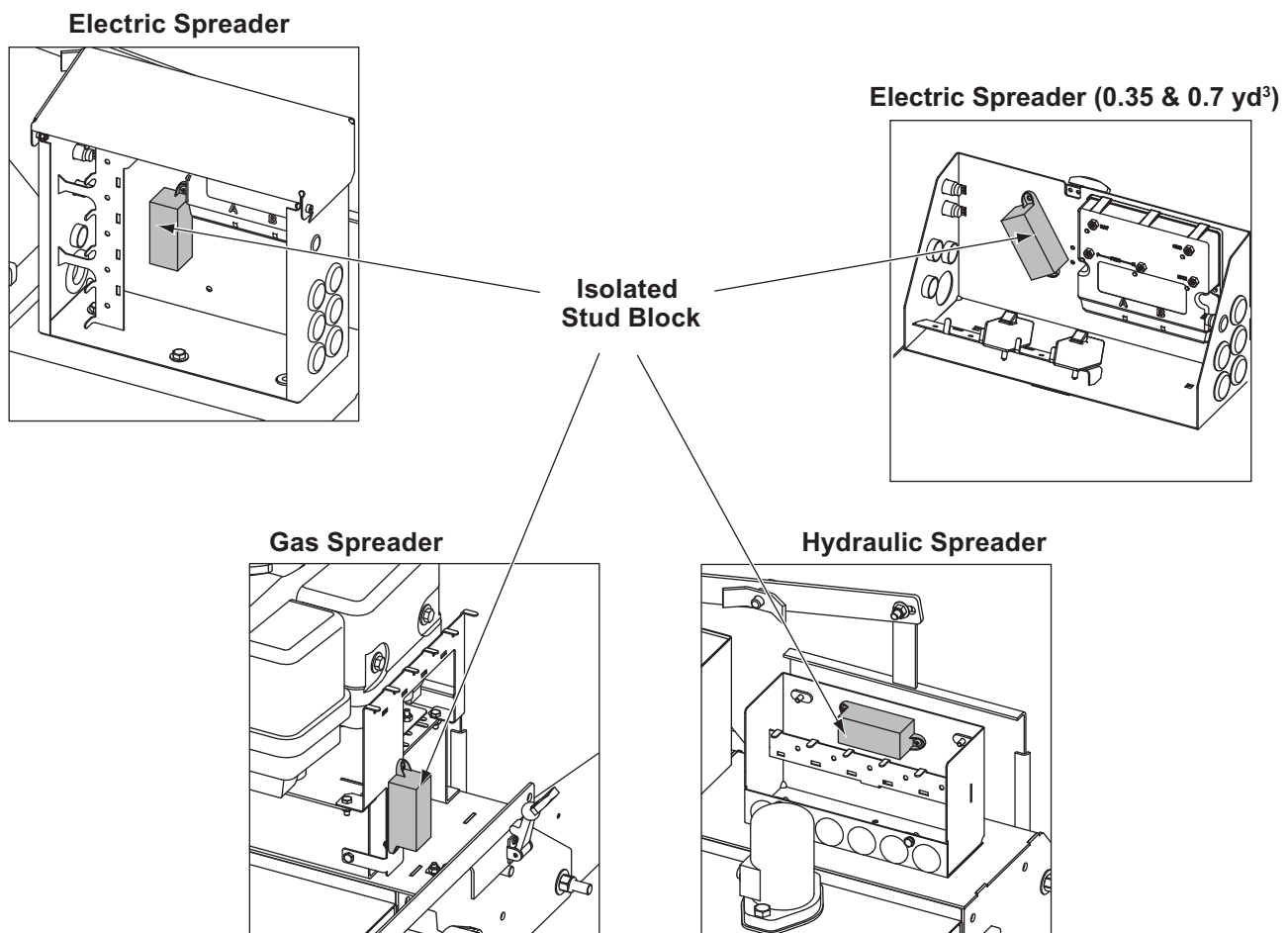

Strobe Light Operation

The strobe light comes with a pre-set flash pattern. In some instances, it is possible for this default pattern to change to a "Steady On" mode. Should this occur, the flash pattern can be changed to any of 11 flash patterns.

1. Cut the wire seal off the yellow wire and strip 1/4" of insulation.
2. With the strobe ON, intermittently apply 12V from the vehicle power supply to the yellow wire until the strobe achieves the desired flash pattern.
3. Reseal the yellow wire.

MODE	PATTERN
0	Random
1	Steady
2	Single
3	Mega
4	Double
5	Triple
6	Quad
7	Quint
8	8 Flash
9	Single-Quad
10	Single H/L
11	Single-Triple-Quint

NOTE: The white wire is not used.

Copyright © 2020 Douglas Dynamics, LLC. All rights reserved. This material may not be reproduced or copied, in whole or in part, in any printed, mechanical, electronic, film, or other distribution and storage media, without the written consent of the company. Authorization to photocopy items for internal or personal use by the company's outlets or spreader owner is granted.

The company reserves the right under its product improvement policy to change construction or design details and furnish equipment when so altered without reference to illustrations or specifications used. This equipment manufacturer or the vehicle manufacturer may require or recommend optional equipment for spreaders. Do not exceed vehicle ratings with a spreader. The company offers a limited warranty for all spreaders and accessories. See separately printed page for this important information.

Printed in U.S.A.