

VIBRATOR KIT

Poly Hopper Spreaders

PARTS LIST

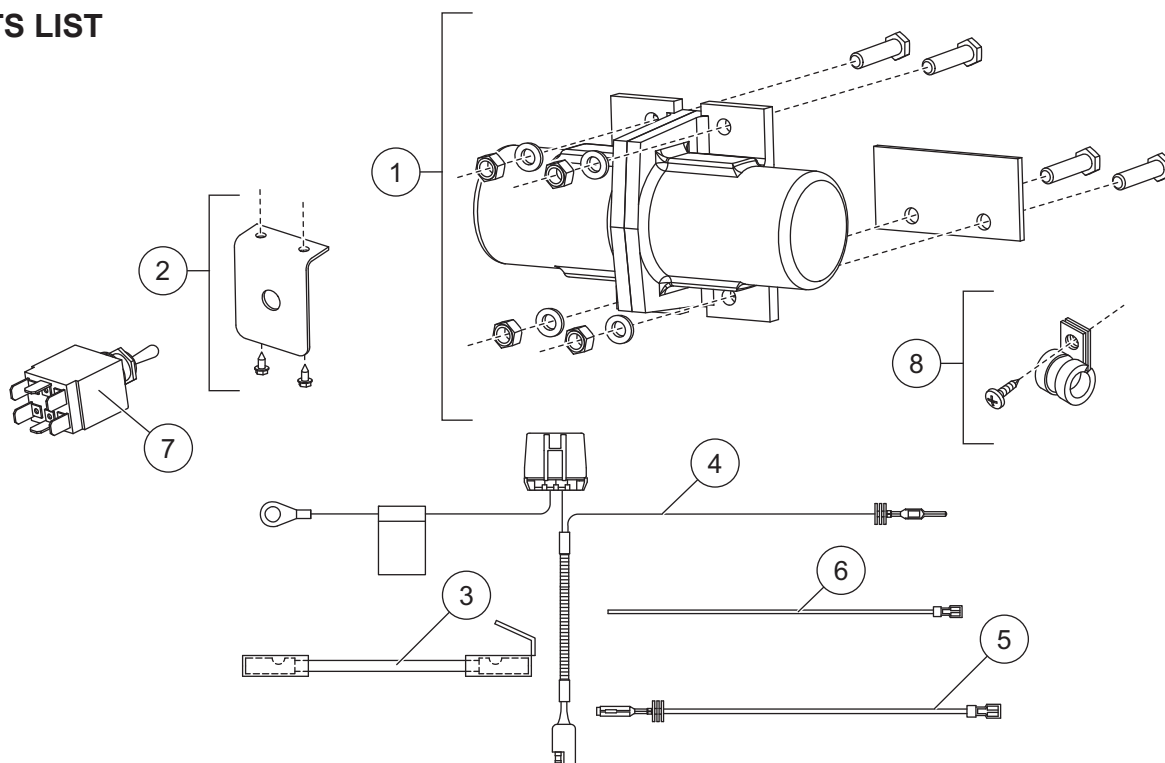

78195 Vibrator Kit							
Item	Part	Qty	Description	Item	Part	Qty	Description
1	68301	1	Vibrator Service Kit	6	78234	1	Ground Wire, Short 84"
2	68297	1	Switch Bracket Kit	7	65353	1	Toggle Switch, ON-OFF-MOM
3	61562	1	4" Jumper Wire	8	68296	5	Clamp Loop #6 Kit
4	78232	1	Vibrator Harness w/Fuse	ns	59223	12	Cable Tie
5	78233	1	Ground Wire, Long 288"	ns	56099	1	Dielectric Grease

ns = not shown

⚠ WARNING

Do not exceed GVWR or GAWR ratings as found on the driver-side vehicle door cornerpost.

⚠ CAUTION

Read this document before installing the vibrator kit.

⚠ CAUTION

Plants can be damaged when exposed to vibrating surface.

⚠ CAUTION

Use standard methods and practices when attaching spreader and installing accessories including proper personal protective safety equipment.

⚠ CAUTION

Contact with a vibrating surface can cause numbness, tingling and loss of dexterity. Users should take breaks and wear gloves to limit vibrating exposure.



REMOVING THE SPREADER

⚠ CAUTION

Before lifting, verify hopper is empty of material. The lifting device must be able to support the spreader's weight.

1. The spreader can be removed from the truck bed either by lifting the spreader by the four molded-in handles located on the corner legs or by sliding the spreader out of the truck bed onto the ground.
2. To remove the spreader from the truck without a lifting device, first make sure all material has been removed from the spreader and the chute is detached. To empty the spreader and remove the chute:

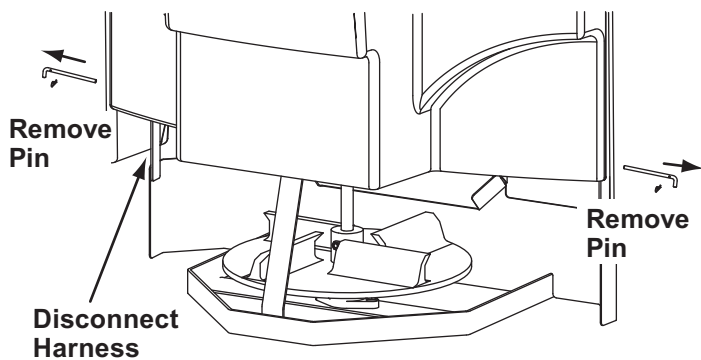

- a. Remove the two pins that hold the chute to the hopper body.
 - b. Disconnect the spinner motor connector.
 - c. Grasp the chute, raise it and remove it from the hopper body.
 - d. Operate the hopper to convey all material from the spreader.
3. Disconnect the electrical connections at the spreader.
 4. Remove any means used to attach the spreader to the truck bed and ensure the lids are closed securely.

5. To remove the spreader without a lifting device, two or more people are recommended. Move spreader rearward until it balances at the rear of the bed. Carefully lower the back of the spreader to the ground so it is resting on its feet.
6. Tip the spreader up so it is fully supported by the feet.

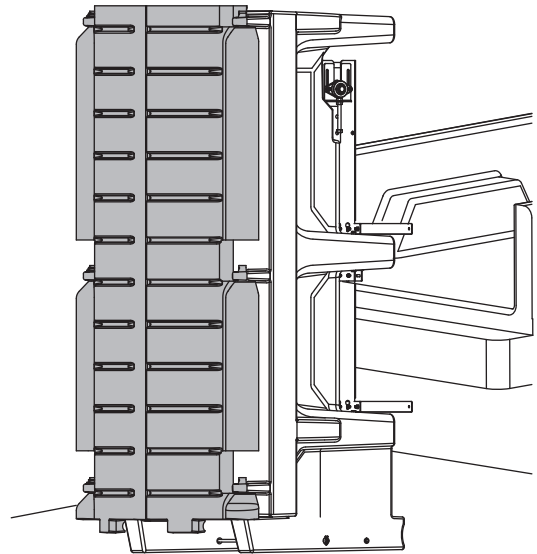

7. **Do not leave an unsecured spreader standing on its feet.** Lower the spreader so it is resting on its 6 legs and place spacers under the legs so the feet at the rear of the spreader are off the ground.

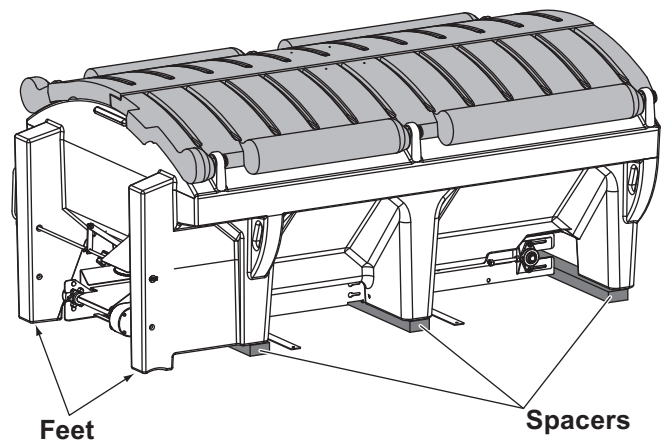

INSTALLATION INSTRUCTIONS

Vibrator Installation

1. Locate the wiring harness in the kit with the fuse holder. At the spreader module, use a cable tie to secure the fuse holder to the cables approximately 3" from the module cover. Continue to secure the vibrator harness to the wiring harness with cable ties.
2. Remove the terminal lock on the wire end of the spreader side 4-pin connector. Remove the dust plug from position D and insert the male terminal on the end of the 12 gauge black wire. Replace the terminal lock on the connector.

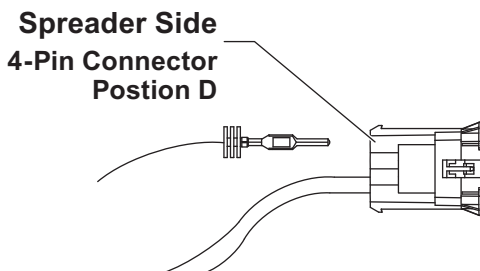

3. Remove the terminal lock on the wire end of the vehicle side 4-pin connector. Remove the dust plug from position D and insert the female terminal on the end of the long 288" black wire supplied. Replace the terminal lock on the connector.

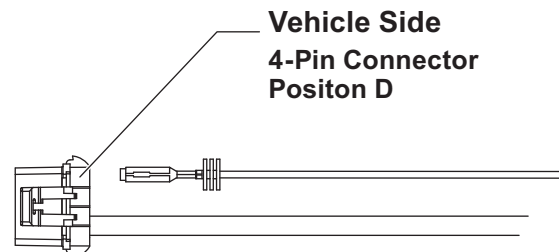

4. Install the 288" black wire along the vehicle side wiring harness and into the cab of the truck. Avoid any hot or moving parts and sharp edges.

Spreader Side Wiring

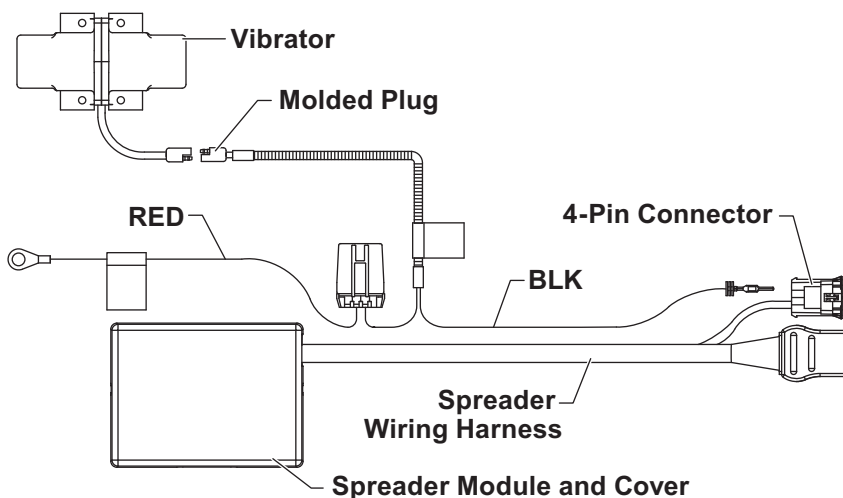

Vehicle Side Wiring

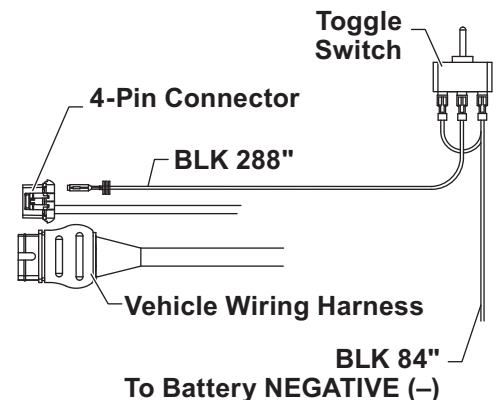

Switch Placement

⚠ CAUTION

Do not alter, modify, or install additional components in shaded areas of the illustration below. Failure to comply may interfere with air bag deployment or cause injury to operator in an accident.

⚠ CAUTION

Before drilling holes, check to be sure that no vehicle wiring or other components could be damaged.

When choosing a location for your switch, it should be mounted in easy reach of the vehicle operator and not restricting access to vehicle controls or vehicle instrumentation. Do not mount the switch in areas prohibited by the vehicle manufacturer for crash worthiness. See the vehicle's body builder's book, owner's manual, or service manual for details. The shaded areas in the illustration below show the most commonly restricted areas.

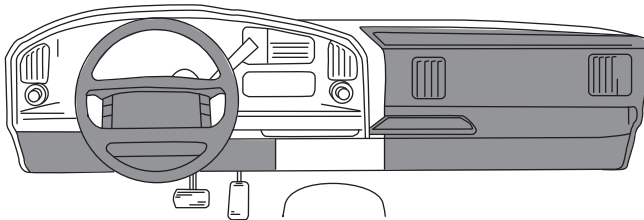

Switch Installation

- In the cab, mount the switch bracket using the supplied #10 x 1" tapping screws and #10 lock washers.
- Orient the toggle switch as shown. Connect the receptacle at the end of the 288" black wire to the bottom center spade on the switch. Connect the 4" jumper wire supplied in the kit to the lower left and lower right spade terminals. Connect the receptacle on the 84" black wire supplied in the kit to exposed spade terminal of the 4" jumper wire.

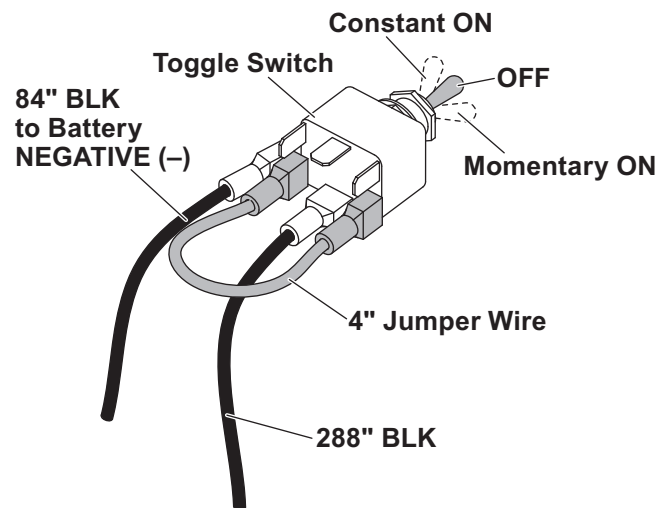

The toggle switch is a 3-position switch. The center position is the "OFF" position. In one direction, the switch is in the "Constant ON" position and in the opposite direction, it is in the "Momentary ON" position.

- Remove the nut from the toggle switch. Position the switch in the switch bracket hole. Reinstall the nut and tighten until it is secure in the bracket.
- Route the 84" 12 gauge black wire to the truck battery and connect to the NEGATIVE (-) battery terminal. Ring terminal not provided.

Vibrator Installation

9. Remove the 5/8" x 6" idler take-up bolt and nuts from the driver's side bracket on the forward end of the sill.

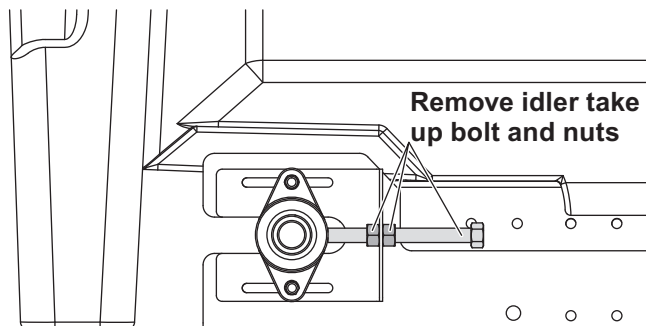

⚠ CAUTION

Before drilling any holes, check both sides of the material for any wires, fuel lines, fuel tanks, etc. that may be damaged by drilling.

10. Locate the four holes approximately 12-3/8" from the forward end of the driver-side sill. If the holes are not pre-drilled, locate and drill four 7/16" diameter holes as shown.

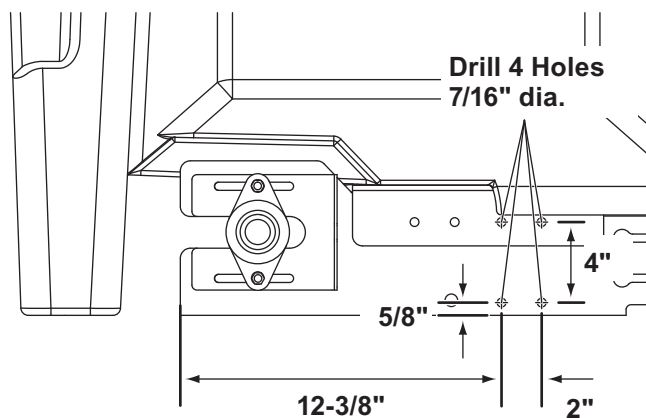

The fasteners holding the hopper to the stainless steel sill may have to be loosened and the hopper body centered on the sill to install the vibrator.

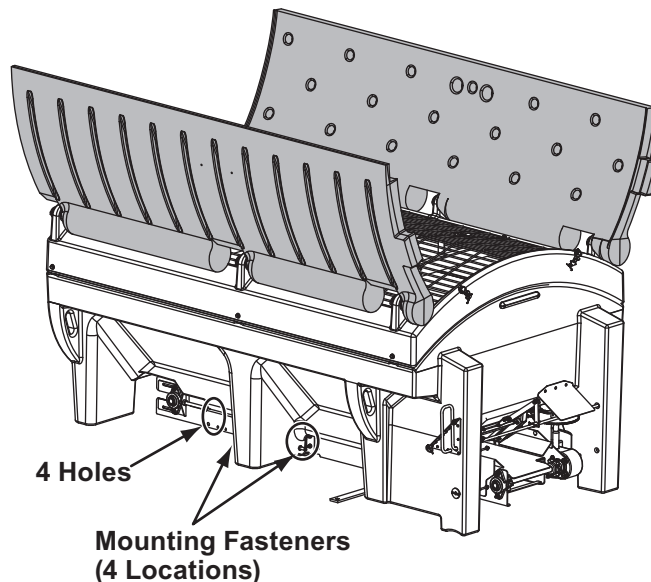

11. Install the vibrator with the wire lead up and spacer plate into the four holes using 3/8" x 1-1/2" cap screws, washers and 3/8" locknuts. Insert the 3/8" cap screws from the inside through the sill and into the vibrator. Secure with washers and 3/8" locknuts on the vibrator side as shown.

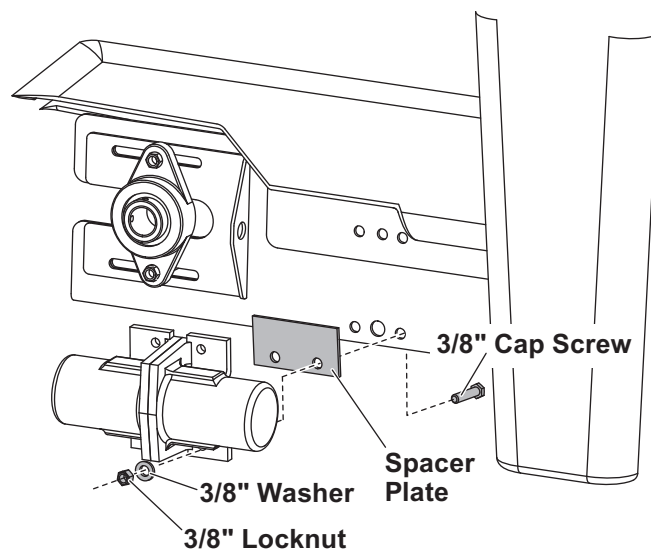

12. Install the 5/8" x 4" take up bolt and nuts provided in the kit in place of the 6" bolt removed in step 9.

⚠ CAUTION

Before drilling any holes, check both sides of the material for any wires, fuel lines, fuel tanks, etc. that may be damaged by drilling.

13. Drill four 3/4" holes through both sides of the middle and rear legs of the poly hopper as shown.

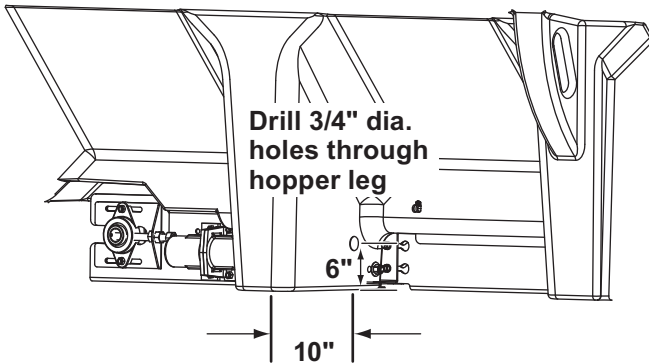

14. Route the 72" harness lead with convoluted tubing from the harness installed in Steps 1–3 through the four holes drilled the poly hopper legs, and connect the molded plug to the vibrator lead.
15. Secure the molded plugs to the hopper body using #6 clamp loops and #12 tapping screws within 2" of each plug, as shown.

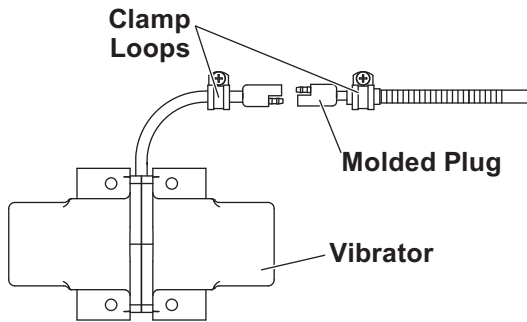

16. Secure the convoluted tubing to the hopper body using #6 clamp loops and #12 tapping screws. Drill 3/32" pilot holes as needed.

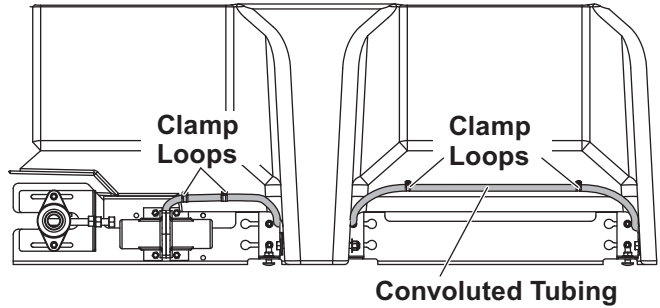

17. Secure excess harness length to the hopper body over the module cover with a clamp loop and tapping screw.
18. Retighten the mounting fasteners between the hopper body and the sill until both sides contact the hopper body.
19. Remove the cover from the spreader module and install the red wire with a ring terminal from the fuse harness to the battery terminal on the left side of the module. Use dielectric grease as needed and reinstall the module cover.

Spreader Side Wiring

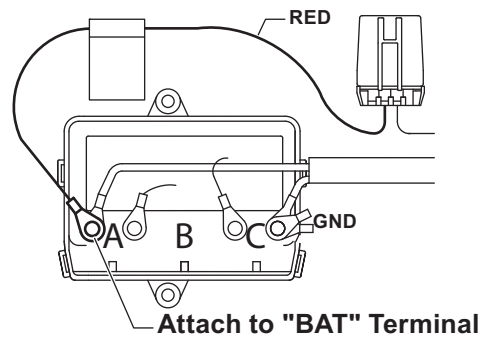

MOUNTING THE SPREADER

NOTE: Periodically throughout the snow and ice control season, verify mounting devices are secure.

⚠ CAUTION

Before lifting, verify hopper is empty of material. The lifting device must be able to support the spreader's weight.

1. The spreader can be moved into the truck bed either by lifting the spreader by the four molded-in handles located on the corner legs or by sliding the spreader into the truck bed from the ground.

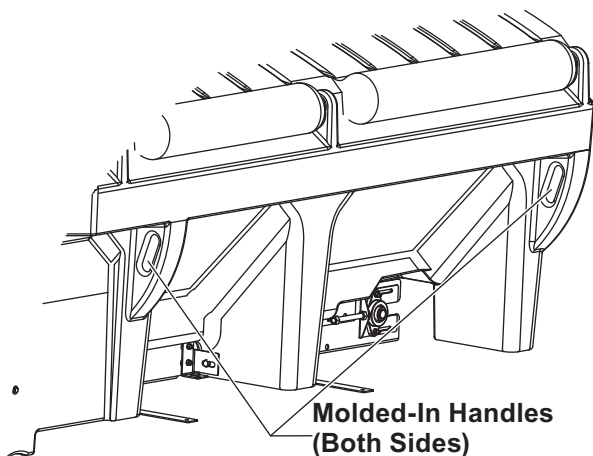

2. To lift the spreader into the truck bed from the ground, stand the spreader up on the feet at the rear of the spreader. The chute must be removed.

3. Position spreader on its feet at the rear of the truck.

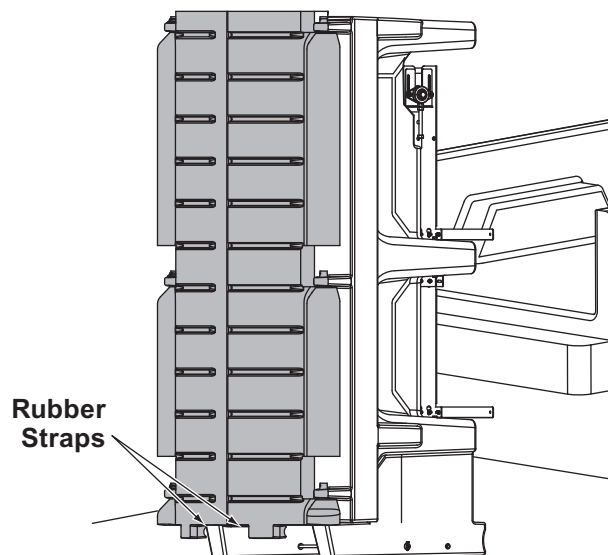

4. Tip the spreader toward the truck until the sill rests on the rear edge of the truck bed.

5. Lift the rear of the spreader and slide it into the truck bed. Two or more people are recommended for this task.

⚠ WARNING

Spreader shall be bolted to vehicle frame. Do not rely on the tie-down chains alone to hold spreader in vehicle.

6. Install the spacer between the end of the sill and the front of the truck bed as shown.

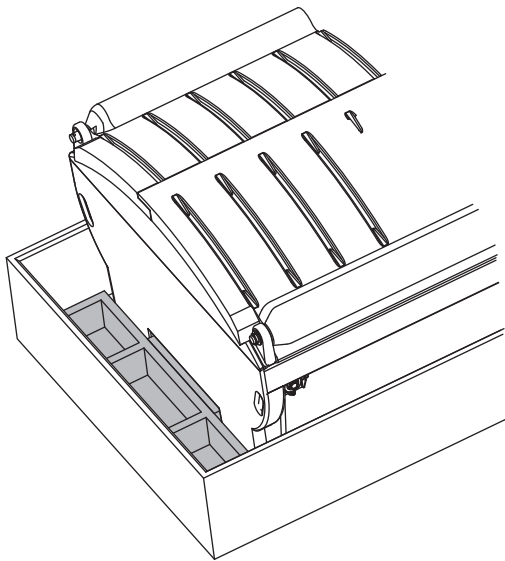

7. Center the spreader in the truck.

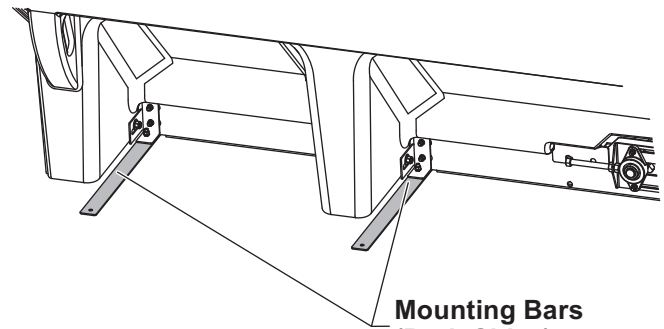

**Mounting Bars
(Both Sides)**

8. Fasten the spreader to the truck frame using the mounting bars and existing holes and hardware.

9. To assemble the chute to the spreader:
 - a. Select the height for the chute assembly.
The upper chute position is typically used for pickup truck installations.
 - b. Remove the extended deflector if used in the upper position.

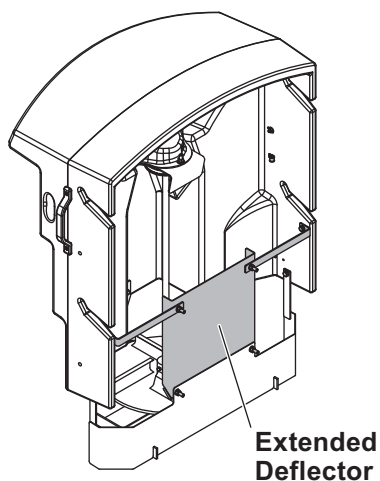

- c. Lift the chute onto the feed gate actuator bar and slide it down into place.
 - d. Align the holes in the hopper body with the threaded inserts in the chute, and install the pins to secure the chute to the hopper body.
 - e. Connect the spinner motor wiring harness.
10. Connect the vehicle and spreader wiring harnesses and the 4-pin connectors between the vehicle and the spreader.

Copyright © 2010 Douglas Dynamics, L.L.C. All rights reserved. This material may not be reproduced or copied, in whole or in part, in any printed, mechanical, electronic, film or other distribution and storage media, without the written consent of the company. Authorization to photocopy items for internal or personal use by the company's outlets or spreader owner is granted.

The company reserves the right under its product improvement policy to change construction or design details and furnish equipment when so altered without reference to illustrations or specifications used. This equipment manufacturer or the vehicle manufacturer may require or recommend optional equipment for spreaders. Do not exceed vehicle ratings with a spreader. The company offers a limited warranty for all spreaders and accessories. See separately printed page for this important information.

Printed in U.S.A.
