

Dual Lock Mounting Kit Installation Instructions

The Dual Lock Mounting Kit will secure your FISHER® joystick solenoid control to interior cab surfaces. Possible mounting areas may include the control bracket, front or side of dash, center console, etc. Once the control is properly mounted it can be easily removed and stored.

The control should be installed within easy reach of the operator but must not interfere with the operation of the vehicle controls, driver's view of instrument panel gauges and roadway, or air bag supplemental restraint system.

The joystick solenoid control can easily be removed by applying a sideways lifting motion to the control. Do not apply excessive force to the control. If the control does not release, gently pry up in the opening under the control with a screwdriver or other flat object.

Installation should be done at temperatures above 60° F (15.6° C).

1. Select an area of the cab where the control is to be mounted. Use the optional four foot long cable extension, if additional wire length is needed.
2. Clean the installation area and surface of control with isopropyl alcohol or mineral spirits. Allow surface to dry for fifteen (15) minutes.
3. Determine length of dual locking strip required. **Do not obstruct the ON/OFF switch.**

For flat surfaces: Use the full length locking strips mounted along the back or side of control. Strips may be placed on the back or the side of the control.

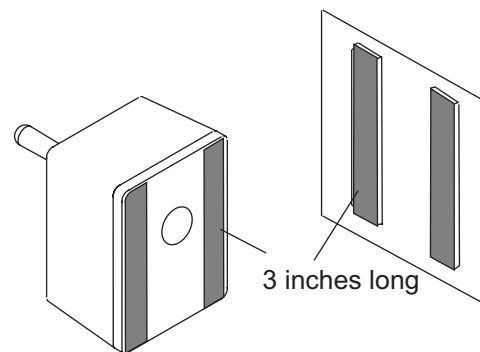

For curved surfaces: Cut the locking strips to 2 inches. These strips must be placed parallel to the curved surface.

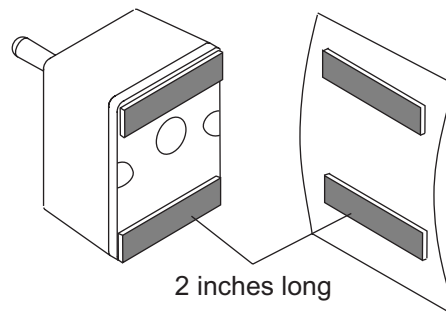

4. Once the mounted surfaces are prepared, remove the adhesive back protection strip and press the locking strips into place. Apply pressure across entire surface to work out any trapped air bubbles. **Allow the locking strip adhesive to set for 24 hours before mounting the control to the cab surface.**

Fisher Engineering reserves the right under its product improvement policy to change construction or design details and furnish equipment when so altered without reference to illustrations or specifications used herein. Fisher Engineering and the vehicle manufacturer may require and/or recommend optional equipment for snow removal. Fisher Engineering offers a limited warranty for all snowplows and accessories. See separately printed page for this important information. The following are registered (®) and unregistered (™) trademarks of Douglas Dynamics, L.L.C.: FISHER®