



Snowplow

Attachment Kit Parts Lists and Diagrams

Table of Contents

Attachment Assembly 2

Attachment Bolt Bag Parts List 3

A-Frame, Center Deflector 3

U-Bolt Assembly and A-Frame Stop Kit Parts Lists 3

Connecting Pin 4

Jack Leg and Support 4

Torsion Spring 4

ATTACHMENT KIT PARTS LIST

8440-1 Attachment Kit					
Part #	Qty	Description	Part #	Qty	Description
21484-1	1	Push Assembly	8555	1	Chain, 5/16" x 108"
	1	Center Deflector	20997	1	Bolt Bag
21001 or		for bolted A-Frame	21846	1	Headgear
21873		for welded A-Frame	8551	1	Release Rod
20988	1	V-Plow Pivot Pin	8514	2	Headgear Brace
63508	1	Rubber Flap	95226	1	Small Parts Kit , 8440-1
63509	1	Mounting Plate - PS	95226 Small Parts Kit		
63510	1	Mounting Plate - DS	20182	1	Torsion Spring
21920	1	Lift Arm	20795	2	Flexible Blade Guide, 26"
20491	1	Jack Leg	22161	1	A-Frame Stop Kit
8533	1	Lower Gear	8499	1	Jack Lever
20488	1	Jack Support			

8440-1
V

EZ-V® SNOWPLOW ATTACHMENT ASSEMBLY

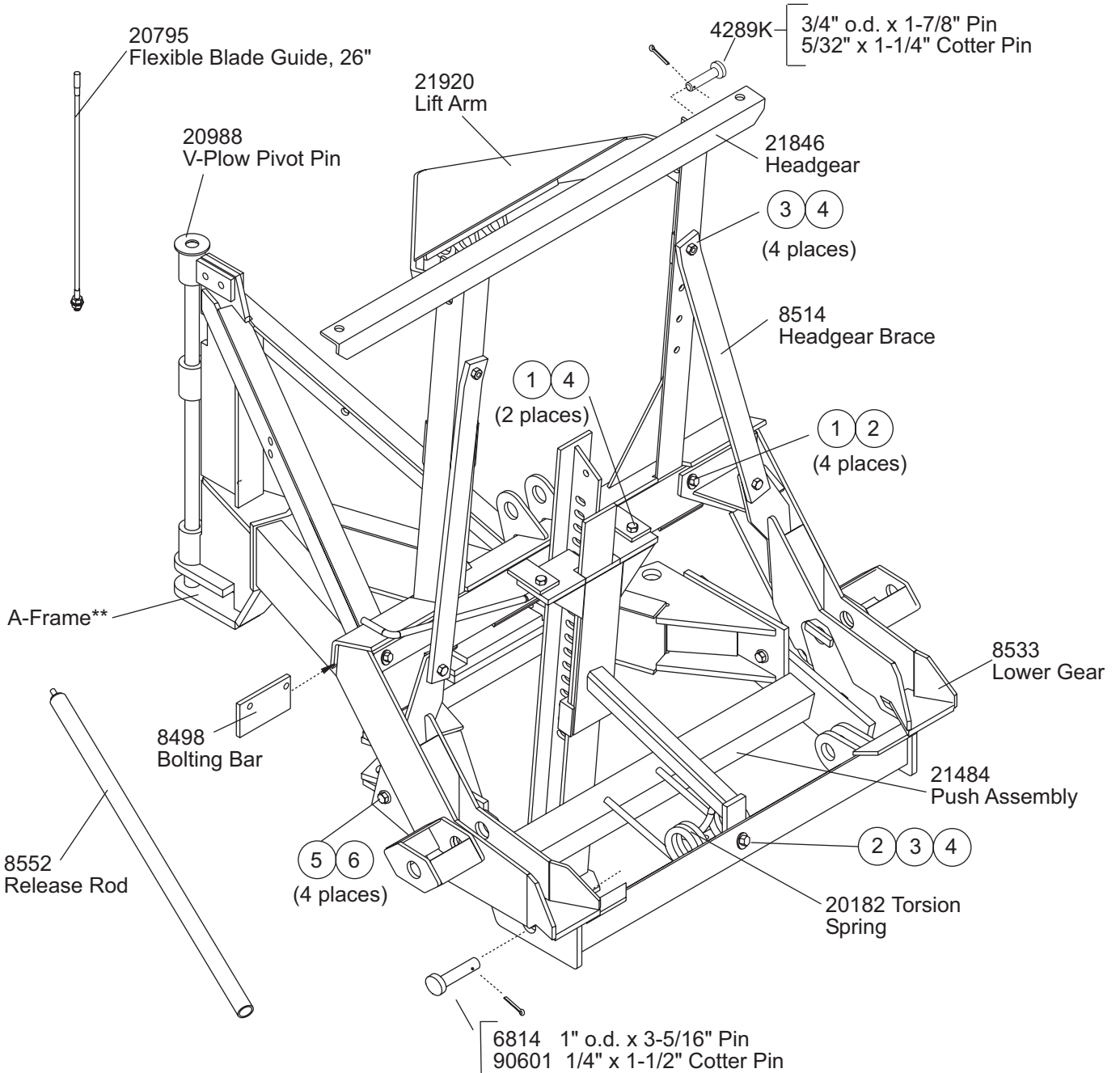

** packed in 21442 Kit

EZ-V® SNOWPLOW A-FRAME

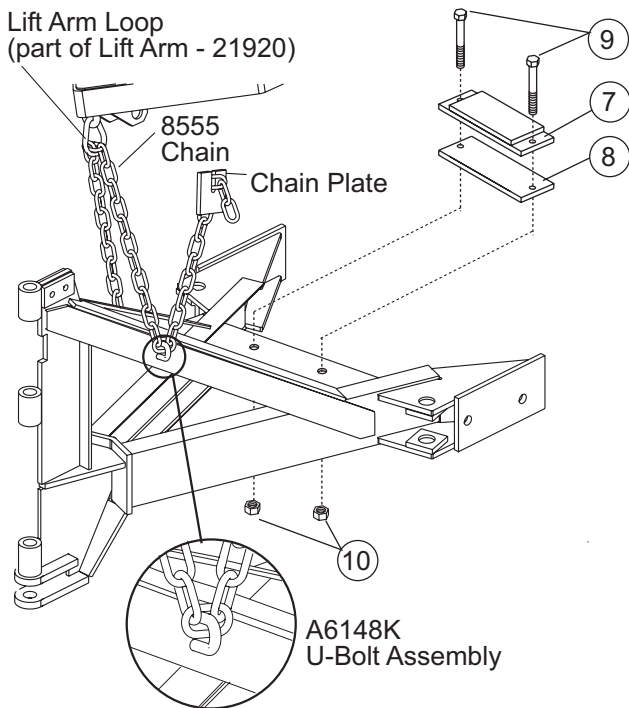

CENTER DEFLECTOR

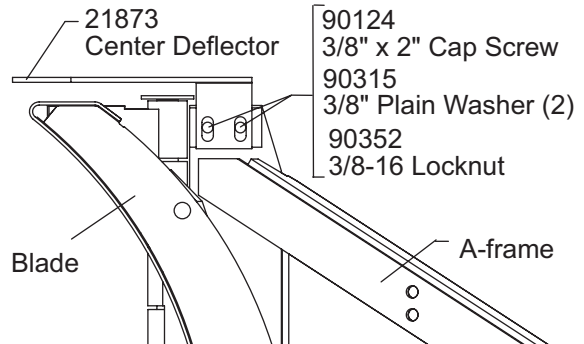

U-Bolt Assembly – A6148K

Part #	Qty	Description
90453	1	3/8-16 U-Bolt Gr. 5
90361	2	3/8" Lock Washer
90334	2	3/8-16 Nut

A-Frame Stop Kit – 22161

Ref #	Part #	Qty	Description
7	22157	1	Stop Assembly
8	22154	3	Rubber Spacer Plate
9	98011	2	3/8-16 Full Thread Gr. 5 Cap Screw
10	90352	2	3/8-16 Locknut

Bolt Bag – 20997

Ref #	Part #	Qty	Description	Ref #	Part #	Qty	Description
ns	7794	1	Spring –1/2" o.d. x 2"	-	*	2	1/2" x 2-1/2" Gr. 5 Cap Screw
ns	26463	1	1/4" x 2" Slotted Type Spring Pin	-	*	2	1/4-20 x 3" Gr. 5 Cap Screw
-	*	2	3/4" o.d. x 1-7/8" Pin	ns	90361	5	3/8" Lock Washer
-	90658	3	5/32" x 1-1/4" Cotter Pin	ns	90334	6	3/8-16 Nut
-	90601	4	1/4" x 1-1/2" Cotter Pin	ns	90352	4	3/8-16 Locknut
-	90124	2	3/8-16 x 2" Gr.5 Cap Screw	-	*	3	3/8-16 U-Bolt
-	90315	4	3/8" Plain Washer	ns	90217	4	1/2-13 x 2" Gr. 5 Cap Screw
-	6814	2	1" o.d. x 3-5/16" Clevis Pin	1	90575	7	1/2-13 x 1-1/4" Gr. 5 Cap Screw
ns	8173	1	Jack Handle (4" Long)	2	90572	9	1/2" Gr. 8 Flat Washer
ns	821	2	Spring – 1" i.d. x 3-1/2"	3	90210	5	1/2-13 x 1-1/2" Gr. 5 Cap Screw
ns	6815	2	Connecting Pin With Handle	4	90593	13	1/2-13 Gr. C Flanged Locknut
ns	90359	2	1/4 Lock Washer	5	98003	4	5/8-11x 2" Flanged Head Gr. 8
ns	90350	2	1/4-20 Locknut	6	98004	4	5/8-11 Gr.8 Flanged Locknut
ns	8741	1	Cable Boot Bracket	ns	90675	2	5/16-18 Locknut
ns	90042	2	5/16-18 x 1" Gr.5 Cap Screw	ns	90313	4	5/16 Plain Washer

* available as part of service kit only

ns = not shown

CONNECTING PIN SERVICE KIT - 6920K

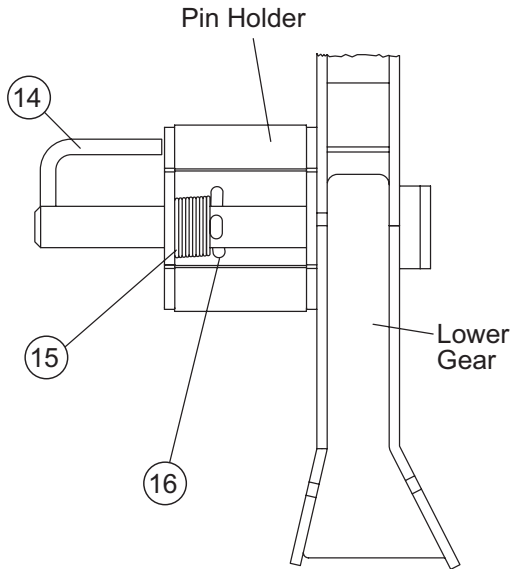

TORSION SPRING SERVICE KIT - 20185

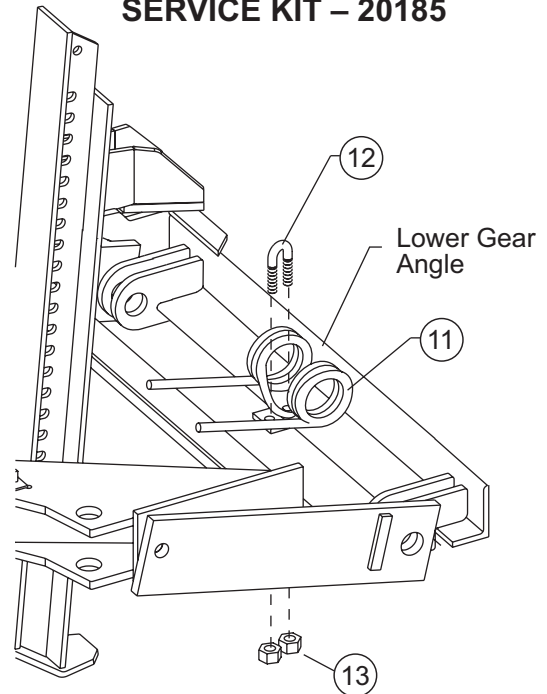

JACK LEG AND SUPPORT

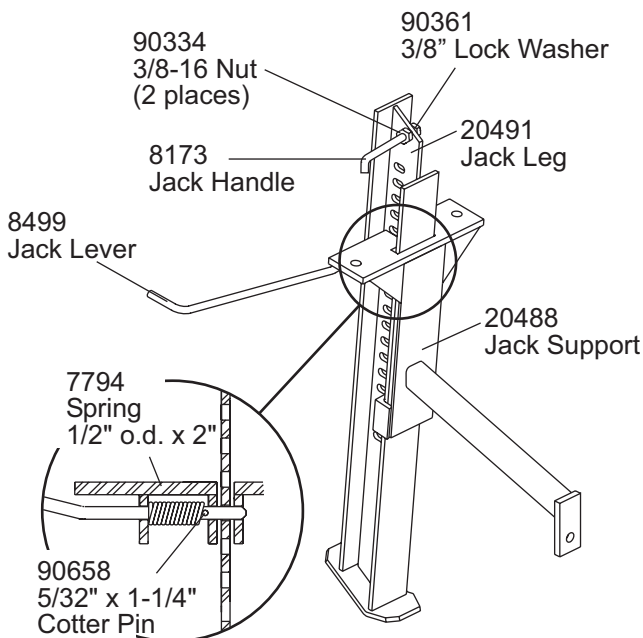

Torsion Spring Service Kit - 20185			
Ref #	Part #	Qty	Description
11	20182	1	Torsion Spring
12	*	1	3/8-16 U-Bolt
13	90352	2	3/8-16 Locknut
ns	20183	1	Tab
ns	*	1	Gusset
* available as part of service kit only			
ns = not shown			

Connecting Pin Service Kit - 6920K			
Ref #	Part #	Qty	Description
14	6815	2	Connecting Pin with Handle
15	821	2	1" i.d. x 3-1/2" Spring
16	90601	2	1/4" x 1-1/2" Cotter Pin

Copyright © 2002 Douglas Dynamics. L.L.C. All rights reserved. This material may not be reproduced or copied, in whole or in part, in any printed, mechanical, electronic, film or other distribution and storage media, without the written consent of Fisher Engineering. Authorization to photocopy items for internal or personal use by Fisher Engineering outlets is granted.

Fisher Engineering reserves the right under its product improvement policy to change construction or design details and furnish equipment when so altered without reference to illustrations or specifications used herein. Fisher Engineering and the vehicle manufacturer may require and/or recommend optional equipment for snow removal. Fisher Engineering offers a limited warranty for all snowplows and accessories. See separately printed page for this important information. The following are registered (®) trademarks of Douglas Dynamics, L.L.C.: EZ-V®, FISHER®