

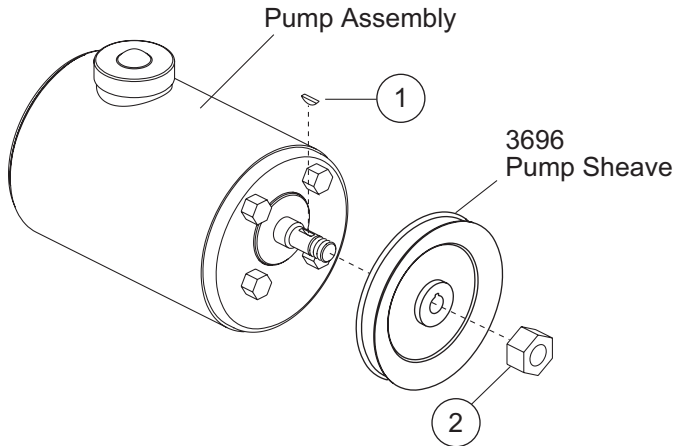

Pump Assembly

Pump Service Literature



A2311 & A5075 Pump Assemblies			
Item	Part	Qty	Description
1	2314	1	Shaft Key
2	2310	2	1/2-20 Hex Locknut GB
ns	5037	1	Retaining Ring
ns	8459	4	Fastener Seal
ns	5034	1	Shaft Seal, #CR6203
ns	2768	1	Shaft Seal, #6141
ns	5497	1	Pump Magnet
ns	90638	4	3/8-16 x 5/8 Hex Cap Screw G5
ns	8460	1	O-Ring
ns	4461K	2	Dipstick and Cap Assembly
ns = not shown			

INSTALLATION INSTRUCTIONS

1. Drop blade and fully compress lift ram.
2. Remove the old pump assembly. Drain fluid from the reservoir. Check magnet in reservoir for metal particles.
3. If metal contamination is found, the hoses and rams must be disassembled, flushed, and inspected. The source of metal contamination is usually one or more of the rams.
4. Repair or replace components as necessary and reinstall.
5. Replace or install return line in-line filter (PN 8764K) in all but Ford applications.
6. To drain the used fluid from the hydraulic angle rams when disassembly is not required,
 - a. Remove the quick disconnects from hoses attached to angle rams.
 - b. Place the open ends of the hoses in a container to collect the used fluid.
 - c. Manually move the blade to retract each ram, forcing out the used fluid.
 - d. Reattach the hydraulic fittings.
7. Properly dispose of all used hydraulic fluid.
8. Remove the pump sheave from the pump shaft and reinstall it on the new pump assembly using the new shaft key and locknut provided. Torque the 1/2" locknut to 85 ft-lb.
9. Install the new pump assembly and fill the reservoir to the indicated mark on the dipstick.
10. Start the engine and operate all the blade functions to fill the rams with fluid. Refill the reservoir if needed.

⚠ CAUTION
Pump tank fill must be vertical to engine.

⚠ CAUTION
Keep hoses away from hot or moving engine components. Failure to do so may cause hose to burst, resulting in possible fire.

A2311
A5075

Copyright © 2004 Douglas Dynamics, L.L.C. All rights reserved. This material may not be reproduced or copied, in whole or in part, in any printed, mechanical, electronic, film or other distribution and storage media, without the written consent of Fisher Engineering. Authorization to photocopy items for internal or personal use by Fisher Engineering outlets or snowplow owner is granted.

Fisher Engineering reserves the right under its product improvement policy to change construction or design details and furnish equipment when so altered without reference to illustrations or specifications used. Fisher Engineering and the vehicle manufacturer may require and/or recommend optional equipment for snow removal. Do not exceed vehicle ratings with a snowplow. Fisher Engineering offers a limited warranty for all snowplows and accessories. See separately printed page for this important information. The following is a registered (®) trademark of Douglas Dynamics, L.L.C.: FISHER®.