



# Attachment Kit Installation Instructions

## Universal Commercial Attachments

**⚠ CAUTION**

Read this document before installing the snowplow.

**⚠ CAUTION**

See your FISHER® outlet for application recommendations. The Kit Selection Guide has specific vehicle and snowplow requirements.

**SAFETY DEFINITIONS**

**⚠ WARNING**

Indicates a potentially hazardous situation that, if not avoided, could result in death or serious personal injury.

**⚠ CAUTION**

Indicates a potentially hazardous situation that, if not avoided, could result in damage to product or property.

**NOTE:** Identifies tips, helpful hints, and maintenance information the owner/operator should know.

**SAFETY PRECAUTIONS**

Improper installation and operation could cause personal injury, and/or equipment and property damage. Read and understand labels and the *Owner's Manual* before installing, operating, or making adjustments.

**⚠ WARNING**

Lower blade when vehicle is parked. Temperature changes could change hydraulic pressure, causing the blade to drop unexpectedly or damaging hydraulic components. Failure to do this can result in serious personal injury.

**⚠ WARNING**

Remove blade assembly before placing vehicle on hoist.

**⚠ WARNING**

The driver shall keep bystanders clear of the blade when it is being raised, lowered or angled. Do not stand between the vehicle and the blade or within 8 feet of a moving blade. A moving or falling blade could cause personal injury.

**⚠ WARNING**

Keep hands and feet clear of the blade and A-frame when mounting or removing the snowplow. Moving or falling assemblies could cause personal injury.

**⚠ WARNING**

Do not exceed GVWR or GAWR including blade and ballast. The rating label is found on driver-side vehicle door cornerpost.

**⚠ CAUTION**

Refer to the Kit Selection Guide for minimum vehicle recommendations and ballast requirements.

**⚠ CAUTION**

To prevent accidental movement of the blade, always turn the ON/OFF switch to OFF whenever the snowplow is not in use. The control indicator light will turn off.

**PERSONAL SAFETY**

- Wear only snug-fitting clothing while working on your vehicle or snowplow.
- Do not wear jewelry or a necktie, and secure long hair.
- Wear safety goggles to protect your eyes from battery acid, gasoline, dirt and dust.
- Avoid touching hot surfaces such as the engine, radiator, hoses and exhaust pipes.
- Always have a fire extinguisher rated BC handy, for flammable liquids and electrical fires.

**FIRE AND EXPLOSION****⚠ WARNING**

Gasoline is highly flammable and gasoline vapor is explosive. Never smoke while working on a vehicle. Keep all open flames away from gasoline tanks and lines. Wipe up any spilled gasoline immediately.



Be careful when using gasoline. Do not use gasoline to clean parts. Store only in approved containers away from sources of heat or flame.

**VENTILATION****⚠ WARNING**

Vehicle exhaust contains deadly carbon monoxide (CO) gas. Breathing this gas, even in low concentrations, could cause death. Never operate a vehicle in an enclosed area without venting exhaust to the outside.

**TORQUE CHART****⚠ CAUTION**

Read instructions before assembling. Fasteners should be finger tight until instructed to tighten according to the torque chart. Use standard methods and practices when attaching snowplow including proper personal protective safety equipment.

<b>Recommended Fastener Torque Chart (Ft.-Lb.)</b>			
Size	 SAE Grade 2	 SAE Grade 5	 SAE Grade 8
1/4-20	6	9	13
5/16-18	11	18	28
3/8-16	19	31	46
3/8-24	24	46	68
7/16-14	30	50	75
1/2-13	45	75	115
9/16-12	66	110	165
5/8-11	93	150	225
3/4-10	150	250	370
7/8-9	150	378	591
1-8	220	583	893
<b>Metric Grade 8.8 (Ft.-Lb.)</b>			
Size	Torque	Size	Torque
M 6	7	M 12	60
M 8	17	M 14	95
M 10	35	M 16	155
These torque values apply to fasteners except those noted in the instruction.			

**INSTALLATION INSTRUCTIONS**

**NOTE: To insure proper fit of attachments do not fully tighten any fasteners until told to do so.**

**NOTE: Some cutting, drilling and welding will be necessary to complete this installation.**

1. Remove the bumper and tow hooks, if equipped.
2. Assemble the driver-side pushplate to the beam assembly rear block with two 5/8 x 2" cap screws, lock washers and nuts. Install the hanger tab on the outside of the pushplate using a 5/8 x 2" cap screw in the upper front hole. Install a 5/8 x 2" cap screw in the lower rear hole. Secure the bolts with two 5/8" nuts and lock washers.

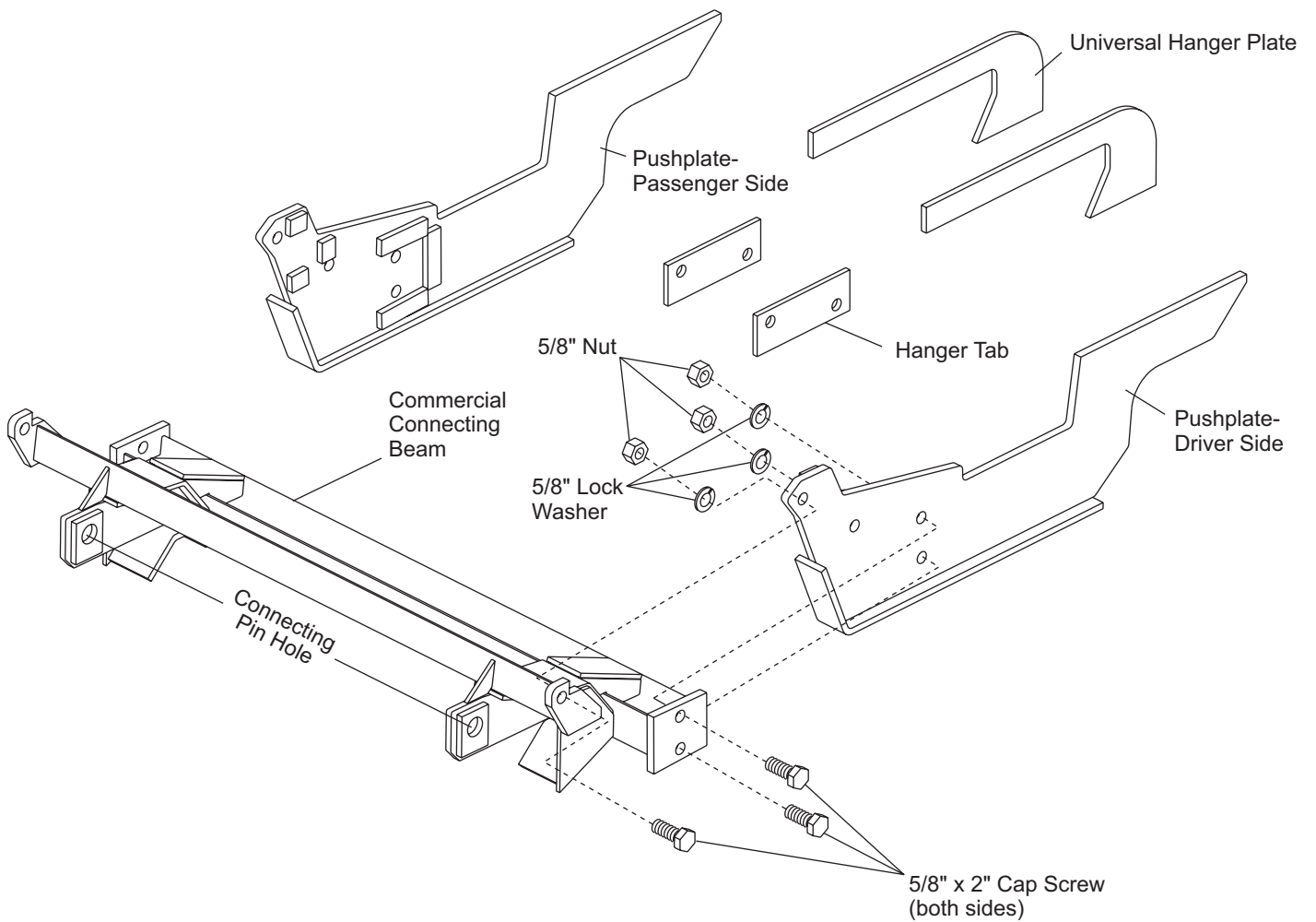

- Repeat on the passenger-side pushplate. Tighten all fasteners.
- Position the assembled unit under the vehicle and center between the wheels. The desired position of the connecting pin hole is 16-1/2" from ground and 2" behind front bumper. The bottom surface of the pushplates must be parallel to the ground (see Figure 1).

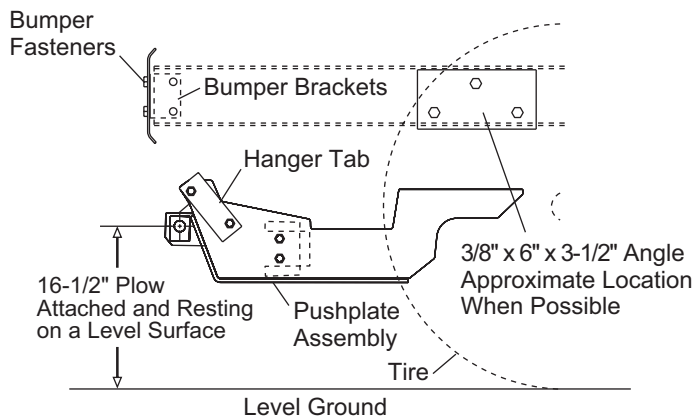

**Figure 1**

On some vehicles the 16-1/2" height will not be possible. In such cases, position the pushplates as high as possible and use the lowest holes in the A-frame when assembling the common attachments.

On other vehicles it may also be necessary to position the plates slightly forward of the front bumper rather than the suggested 1 to 2" behind the bumper (see Figure 2).

The rear portion of the pushplates may have to be cut on certain vehicles to obtain the 1" to 2" distance behind bumper.

**NOTE: Floor stands are recommended to set the pushplate assembly on to hold it in place.**

- To check the position of the pushplate assembly, loosely assemble the upper and lower gear from the common attachment kit and attach the plow lights. Attach them to the connecting beam with the connecting pins found in the common attachment box. Check for proper clearance between the jack stand and the bumper, and the headlights and the vehicle grille.
- Adjust the position of the pushplate assembly to insure proper clearances for the jack leg and plow lights.
- Locate a place on the driver side of the vehicle frame, above the rear section of the pushplate, for attaching a section of the 3/8" x 6" x 3-1/2" angle.

Location requirements include:

- Clearance for bent or flat pieces to connect the rear portion of the pushplates with the 3/8" x 6" x 3-1/2" angle. There should be no interference with any steering or suspension components including axle, tie rods or springs.
- No interference with frame brackets, brake lines, fuel lines, cooling lines or any other obstructions.
- Existing frame holes should be used when available. Others can be drilled when necessary.

Use at least three cap screws through the vehicle frame.

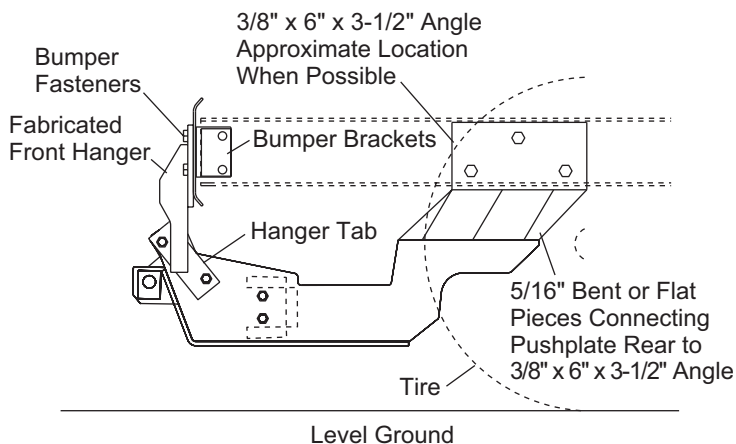

**Figure 2**

7. Cut an appropriate length of the 3/8" x 6" x 3-1/2" angle as needed. Place it against the frame in desired location. Mark and drill 5/8" holes in the angle where needed. Attach to the vehicle frame using 5/8" Gr. 5 cap screws (not provided).
8. Repeat on the passenger side.
9. Fabricate the pieces needed to attach the rear of the pushplate to the bottom of the 3/8" angle. Use the 5/16" flat bar stock provided. Multiple pieces can be used to produce the desired width. A minimum width of 10" is suggested when possible (see Figure 3).

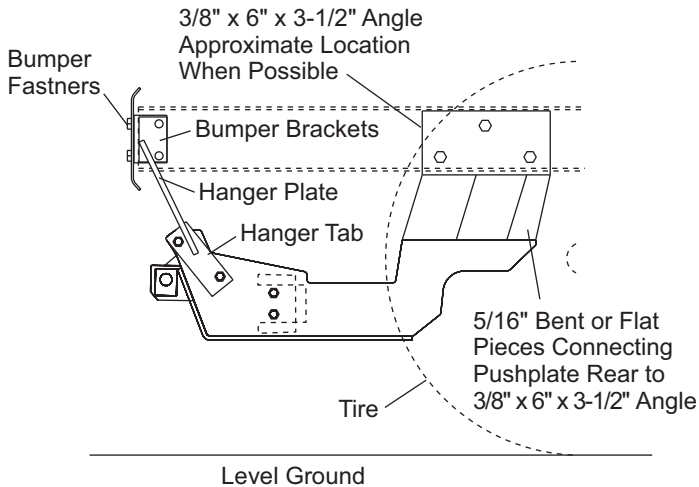

Figure 3

10. Tack weld the fabricated pieces to pushplate and 3/8" angle. Do the same on opposite side.
11. Use the 5/16 x 2" flat bar to fabricate a minimum of two stiffeners that will attach between the pushplate, the pieces that span between the 3/8" x 6" x 3-1/2" angle and the angle itself (see Figure 4).

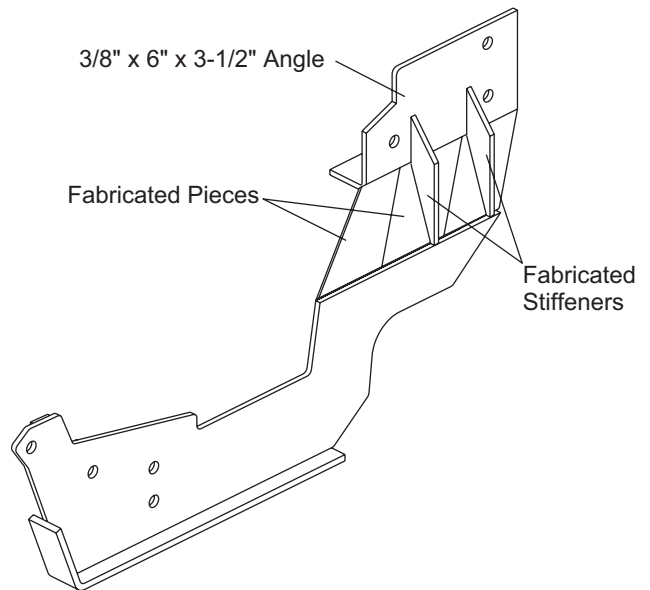

Figure 4

12. Tack weld in place.
13. Install front hanger using method most suitable to fabricate a front hanger for your application.

**Vehicles equipped with tow hooks or bumper brackets**

- a. Fabricate pieces of 5/16 x 4" flat bar so they will fit the area where the tow hooks were, keeping them in front of the spring brackets.
- b. Drill holes in the plates to match the tow hook fastener holes.
- c. Install the plates using the tow hook fasteners when possible.
- d. Cut and bend a hanger plate, as needed, so it will fit between the tow hook plate and the hanger tab attached to the outside of the pushplate (see Figure 3).

- e. Tack weld the hanger. Stiffen, as necessary, by tacking on gussets fabricated from any remaining stock (see Figure 5).

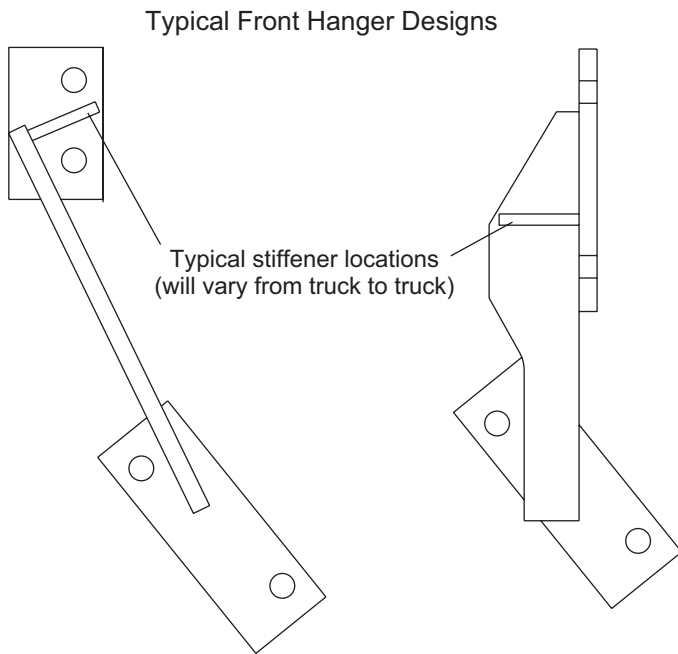

**Figure 5**

- f. Additional stiffness can be achieved by shimming between any hanger parts and stationary vehicle frame members. Use appropriately sized blocks and tack them to the hangers. This will provide a butted connection to the frame upon final installation.
- g. Repeat on the passenger side.

**Vehicles without tow hooks or low profile vehicles**

- a. Cut a piece of 1/2 x 3" flat bar long enough to match up with the bumper bracket holes.
- b. Drill two holes in the flat bar that align with the bumper bracket holes.

- c. Place the 1/2 x 3" flat bar and a spacer the thickness of the bumper against the bumper bracket on the driver side. The spacer will be removed during the final installation when bumper is reinstalled on the vehicle.
- d. Fabricate a piece of 1/2 x 3" flat bar to make a connection between the drilled 1/2 x 3" bumper plate and the hanger tab on the pushplate (see Figure 2).
- e. Tack weld in place. Stiffen, as necessary, by tacking on gussets fabricated from any remaining stock (see Figure 5).
- f. Additional stiffness can be achieved by shimming between any hanger parts and stationary vehicle frame members using appropriately sized blocks and tacking them to the hangers. This will provide a butted connection to the frame upon final installation.
- g. Repeat on the passenger side.

---

**NOTE: Installation of attachments on low profile vehicles will require the use of the lowest hole in the A-frame push ears.**

---

14. Remove the hangers and the pushplate assembly from the vehicle.
15. Weld the pushplate assembly and hangers.
16. Paint the unit when sufficiently cooled from welding.
17. Reinstall the bumper and other previously removed vehicle components.
18. Install the pushplate assembly on the vehicle.
19. Tighten all fasteners according to the torque chart.

---

**NOTE: After five to ten hours of snowplow usage, retorque all pushplate assembly fasteners.**

---

Fisher Engineering reserves the right under its product improvement policy to change construction or design details and furnish equipment when so altered without reference to illustrations or specifications used. Fisher Engineering and the vehicle manufacturer may require and/or recommend optional equipment for snow removal. Do not exceed vehicle ratings with a snowplow. Fisher Engineering offers a limited warranty for all snowplows and accessories. See separately printed page for this important information. The following are registered (®) trademarks of Douglas Dynamics, L.L.C.: FISHER®, Minute Mount®.

**Printed in U.S.A.**