



Fisher Engineering

June 1, 2005
Lit. No. 26407, Rev. 02



the snowplow professionals



Insta-Act[®] Hydraulic Unit

Owner's Manual

▲ CAUTION

Read this manual before operating or servicing snowplow.

This document supersedes all editions with an earlier date.

SNOWPLOW OWNER DATA SHEET

Owner Name: _____

Date Purchased: _____

Outlet Name: _____ Phone: _____

Outlet Address: _____

Vehicle Model/Year: _____

Snowplow Model/Year: _____

Snowplow Type/Size: _____ Weight: _____ lbs/kg

Ballast: No ___ Yes ___ Amount _____ lbs/kg

Insta-Act® Hydraulic Unit Serial Number: _____

Blade Serial Number (located above Warning/Caution label): _____

TABLE OF CONTENTS

Snowplow Owner Data Sheet	2	Snowplow Headlamp Check	18
Preface	5	Antiwear Shoe Adjustment	18
Safety Information	7	Hydraulic System	19
Vehicle Application Information	10	Blade Drop Speed Adjustment	19
Getting To Know Your Snowplow	11	Transporting Snowplow	19
Minute Mount® System	11	Driving and Plowing on Snow and Ice	20
Blades	11	Plowing Snow	20
Common Attachment Kit	11	Parking with Snowplow Attached	21
Peculiar Attachment Kit	12	Towing Disabled or Stuck Vehicle	21
Snowplow Headlamps	12	Removing Snowplow and Storage	22
Insta-Act® Hydraulic Unit	12	Maintenance	24
Cab Controls	13	Aiming Headlamp Beams	24
Accessories and Options	14	Preseason Check	25
Mounting Snowplow To Vehicle	15	Postseason Maintenance	25
Operating Your Snowplow	16	Maintenance and Adjustment	25
Joystick Solenoid Control	16	Lifting	25
Fish-Stik® Hand-Held Control	17	Hydraulic System	26
		Vehicle	28
		Recycle	28
		Emergency Parts/Tools	28
		Troubleshooting Guide	29

PREFACE

This manual has been prepared to acquaint you with the safety information, operation and maintenance of your new FISHER® snowplow. Please read this manual carefully and follow all recommendations.

Before installing a snowplow, make sure your vehicle is equipped with all the vehicle manufacturer's and our required options for snowplowing. This will help ensure profitable and trouble-free operation of your snowplow. Keep this manual accessible. It is a handy reference in case minor service is required.

Your FISHER snowplow Insta-Act® hydraulic unit and blade both have a serial number. Record these serial numbers on the second page of this manual so that you can refer to it when necessary.

When service is necessary, bring your snowplow to your local FISHER outlet. They know your snowplow best and are interested in your complete satisfaction.

The illustrations found in this manual represent typical components. They may not match your exact installation.

SAFETY

SAFETY DEFINITIONS

⚠ WARNING

Indicates a potentially hazardous situation, that if not avoided, could result in death or serious personal injury.

⚠ CAUTION

Indicates a situation that, if not avoided, could result in damage to product or property.

NOTE: Identifies tips, helpful hints, and maintenance information the owner/operator should know.

WARNING/CAUTION & INSTRUCTION LABELS

Become familiar with and inform users about the warning labels on the back of the blade, and the instruction label on the headgear.

Warning/Caution Label

⚠ WARNING

LOWER BLADE WHEN VEHICLE IS PARKED.

REMOVE BLADE ASSEMBLY BEFORE PLACING VEHICLE ON HOIST.

DO NOT EXCEED GVWR OR GAWR INCLUDING BLADE AND BALLAST.

⚠ CAUTION

READ OWNER'S MANUAL BEFORE OPERATING OR SERVICING SNOWPLOW.

TRANSPORT SPEED SHOULD NOT EXCEED 45 MPH. REDUCE SPEED UNDER ADVERSE TRAVEL CONDITIONS.

PLOWING SPEED SHOULD NOT EXCEED 10 MPH.

REMOVE SLACK FROM CARRYING CHAIN BEFORE TRAVELING.

SEE YOUR FISHER OUTLET FOR APPLICATION RECOMMENDATIONS.

21793

Instruction Label



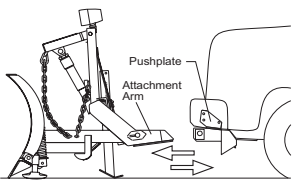
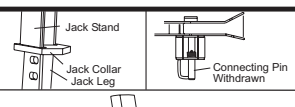
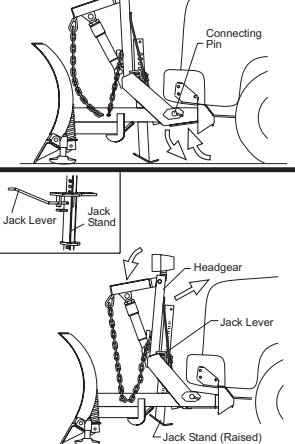

U.S. Patents
4,280,062, 4,999,935,
5,353,530, 5,420,480
and other patents
pending

MOUNTING PLOW		REMOVING PLOW
<p>A.</p> <ol style="list-style-type: none"> 1. Drive vehicle forward fully engaging pushplates into attachment arms. 		<p>C.</p> <ol style="list-style-type: none"> 1. Remove slack from carrying chain and reattach. 2. Back vehicle away from plow.
<p>B.</p> <ol style="list-style-type: none"> 1. Twist connecting pin to release tension. 2. Remove electrical covers on vehicle. 3. Attach electrical connector to corresponding connector on vehicle. 4. Repeat steps B 1-3 on passenger side of vehicle. 5. Connect hydraulic hoses to quick disconnects. (BELT DRIVE ONLY) 		<p>B.</p> <ol style="list-style-type: none"> 1. Disconnect electrical connector and reinsert in protective cover. 2. Insert release rod under jack collar. 3. Push down on release rod as you pull and twist connecting pin. 4. Repeat Steps B 1-3 on passenger side. 5. Disconnect hydraulic hose couplings and cover with dust plugs.
<p>C.</p> <ol style="list-style-type: none"> 1. Release carrying chain and reattach it leaving plenty of slack. 2. Push headgear upward toward vehicle until connecting pins snap in place. 3. Pull jack lever outward and raise the jack stand. 		<p>A.</p> <ol style="list-style-type: none"> 1. Place cab control in "Lower/Float". 2. Push lift arm down. 3. Pull jack lever outward. Jack stand will adjust to proper height.

8248

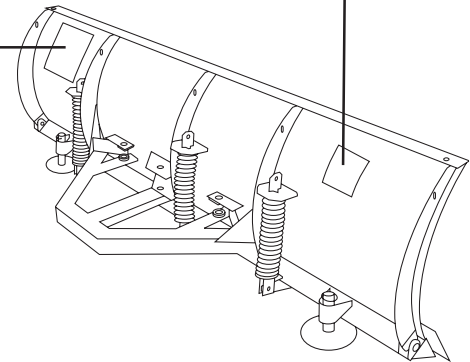

SAFETY

SAFETY PRECAUTIONS

Improper installation and operation could cause personal injury, and/or equipment and property damage. Read and understand labels and the *Owner's Manual* before installing, operating or making adjustments.

WARNING

Lower blade when vehicle is parked. Temperature changes could change hydraulic pressure, causing the blade to drop unexpectedly or damaging hydraulic components. Failure to do this could result in serious personal injury.

WARNING

Remove blade assembly before placing vehicle on hoist.

WARNING

Do not exceed GVWR or GAWR including the blade and ballast. The rating label is found on the driver-side vehicle door cornerpost.

CAUTION

Read Owner's Manual before operating or servicing snowplow.

CAUTION

Transport speed should not exceed 45 mph. Reduce speed under adverse travel conditions.

CAUTION

Plowing speed should not exceed 10 mph.

CAUTION

See your FISHER® outlet for application recommendations.

PERSONAL SAFETY

- Wear only snug-fitting clothing while working on your vehicle or snowplow.
- Do not wear jewelry or a necktie, and secure long hair.
- Wear safety goggles to protect your eyes from battery acid, gasoline, dirt and dust.
- Avoid touching hot surfaces such as the engine, radiator, hoses and exhaust pipes.
- Always have a fire extinguisher rated BC handy, for flammable liquids and electrical fires.

FIRE AND EXPLOSION

WARNING

Gasoline is highly flammable and gasoline vapor is explosive. Never smoke while working on vehicle. Keep all open flames away from gasoline tank and lines. Wipe up any spilled gasoline immediately.

Be careful when using gasoline. Do not use gasoline to clean parts. Store only in approved containers away from sources of heat or flame.

VENTILATION

WARNING

Vehicle exhaust contains deadly carbon monoxide (CO) gas. Breathing this gas, even in low concentrations, could cause death. Never operate a vehicle in an enclosed area without venting exhaust to the outside.

SAFETY

HYDRAULIC SAFETY

⚠ WARNING

Hydraulic fluid under pressure can cause skin injection injury. If you are injured by hydraulic fluid, get medical attention immediately.

- Always inspect hydraulic components and hoses before using. Replace any damaged or worn parts immediately.
- If you suspect a hose leak, DO NOT use your hand to locate it. Use a piece of cardboard or wood.

BATTERY SAFETY

⚠ CAUTION

Batteries normally produce explosive gases which can cause personal injury. Therefore, do not allow flames, sparks or lit tobacco to come near the battery. When charging or working near a battery, always cover your face and protect your eyes, and also provide ventilation.

Batteries contain sulfuric acid which burns skin, eyes and clothing.

Disconnect the battery before removing or replacing any electrical components.

FUSES

The FISHER® vehicle control harness contains two automotive-style fuses. One fuse is for the snowplow park/turn lamp power and the other is for the snowplow control power. If a problem should occur and fuse replacement is necessary, the replacement fuse should be of the same value as the original. Installing a fuse of a larger value could damage the system.

NOISE

Airborne noise emission during use is below 70 dB(A) for the snowplow operator.

VEHICLE APPLICATION INFORMATION

⚠ CAUTION

See your FISHER® outlet for application recommendations. The Kit Selection Guide has specific vehicle and snowplow requirements.

Vehicle application recommendations are based on the following:

- The vehicle with the snowplow installed must comply with applicable Federal Motor Vehicle Safety Standards (FMVSS).
- The vehicle with the snowplow installed must comply with the vehicle manufacturer's stated gross vehicle and axle weight ratings (found on the driver-side door cornerpost of the vehicle) and the front and rear weight distribution ratio. In some cases, rear ballast may be required to comply with these requirements. See Ballast Requirements section.
- FISHER® *Kit Selection Guide* is based on available vehicle capacity for snowplow equipment on a representative vehicle equipped with options commonly used for snowplowing and with 300 lbs. of front seat occupant weight.
- Weights of front seat occupants can be adjusted above 300 lbs. but vehicle with snowplow must not exceed vehicle GVWR or GAWR.
- In some cases there may be additional limitations and requirements.
- Installation, modification and addition of accessories must comply with published FISHER recommendations and instructions. Available capacity decreases as the vehicle is loaded with cargo or other truck equipment or snowplow accessories are installed.
- If there is uncertainty as to whether available capacity exists, the actual vehicle as configured must be weighed.

BALLAST REQUIREMENTS

Ballast (additional weight) is an important part of qualifying vehicles for snowplow eligibility. Rear ballast must be used when necessary to remain in compliance with axle ratings and ratios as specified by the vehicle manufacturer.

If ballast is required, it is important that it be secured properly behind the rear axle. A ballast retainer kit is available.

NOTE: The ballast retainer kit is for snowplow vehicles requiring ballast. See your FISHER® outlet for the correct amount of ballast required. Include the weight of the retainer as part of the ballast requirement. Sand bags are recommended for use as ballast.

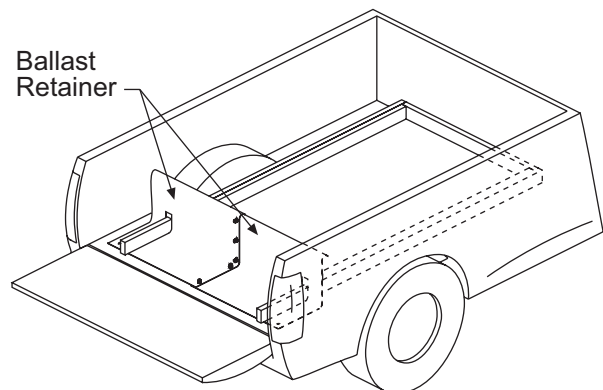

GETTING TO KNOW YOUR SNOWPLOW

Minute Mount® SYSTEM

The Minute Mount System from Fisher Engineering sets the industry standard for detachable snowplow design. It's the quickest and easiest mounting system available. The Minute Mount System shall be installed according to instructions supplied. FISHER® outlets are trained to perform this service and other services for this snowplow.

Most of the snowplow mount can now be removed easily from the truck when it's not being used for plowing. By removing the headgear, lift arm and headlamps every time you remove the plow, you eliminate over 100 lbs. of weight on the front suspension and tires resulting in less wear all year long! This also means improved appearance of your four-wheel-drive or sport-utility vehicle.

BLADES

The FISHER snowplow incorporates a trip-edge design. When the blade strikes an obstacle, the lower edge trips back, compressing the springs on the back side of the blade. When the obstacle is cleared, spring tension is released and the edge is returned to its normal plowing position. Because the blade itself remains upright, plowed snow out in front of the blade stays put. A rigid blade allows you to plow and stack more snow quickly and easily!

LD Series

Available in 6' 9" and 7-1/2' widths, the FISHER LD Series snowplows are designed for compact and light 1/2-ton four-wheel-drive trucks, as well as some sport-utility vehicles. The plows are ideal for homeowners and noncommercial plowing situations. They come standard with a polymer cutting edge. SnoFoil® Assembly (7-1/2' only), Steel Cutting Edge (7-1/2' only), Deflector and Shoe Kit are sold separately.

RD Series

Available in 7' and 7-1/2' widths, the FISHER RD Series snowplows are designed for midsize and 1/2-ton four-wheel-drive trucks, as well as full-size sport-utility vehicles. Our most popular model, these plows are ideal for homeowners, small businesses, and light commercial plowing. Steel Cutting Edge (7-1/2' only), SnoFoil Assembly, and Deflector are sold separately.

HD Series

These popular 8', 8-1/2' and 9' snowplows are the choice of the plowing professional. Built for the business of snowplowing, these rugged plows will withstand the rigors of any and all commercial applications. Designed for 3/4-ton and 1-ton 4x4 trucks, as well as today's new "Super-Duty" vehicles. Steel Cutting Edge, SnoFoil Assembly, and Deflector are sold separately.

MC Series

Designed for trucks in the 17,000–27,500 GVW range, these all-new FISHER 9' and 10' snowplows are now available with the famous FISHER trip-edge design and the Minute Mount System. Built for municipalities and contractors who need to clear parking lots, narrow streets, and intersections, both plows include a trip-edge design (10' – two 5' sections); 8" center-punched, reversible cutting edge; and 2" x 10" lift ram with 2" x 16" angle rams. SnoFoil Assembly and Rubber Deflector are sold separately.

COMMON ATTACHMENT KIT

The common attachment kit is composed of the A-frame and the headgear kit.

A-Frame

The A-frame is attached to the blade assembly with a centered pivot pin. The pivot pin allows the blade assembly to angle left or right 28 degrees, providing excellent snow displacement. The heavy 1" pivot pin is shear-proof under normal operation, assuring a solid connection.

Headgear Kit

The headgear kit is composed of the upper gear, lower gear, lift arm, jack support and jack leg. The lower gear is connected to the pushplates, which are mounted directly to the vehicle frame. The upper gear provides the mounting framework for the FISHER Insta-Act® Hydraulic Unit and the lift arm. The lift ram raises and lowers the blade by moving the lift arm and lift chain. The jack leg, when lowered, supports the snowplow during and after its removal from the vehicle.

GETTING TO KNOW YOUR SNOWPLOW

PECULIAR ATTACHMENT KIT

Fisher Engineering has designed a peculiar (custom) attachment kit for most vehicles. Due to the differences between vehicle models, the kits are not interchangeable.

The peculiar attachment kit fastens to the underside of the vehicle frame. It is engineered to provide the primary connecting points between the plow assembly and the vehicle. The weight of the Minute Mount® system is distributed to the frame of your vehicle by the pushplates.

SNOWPLOW HEADLAMPS

⚠ WARNING

Your vehicle must be equipped with snowplow headlamps and directional lights.

The snowplow headlamps include a set of rectangular, dual-beam halogen headlamps with combination park and turn signals. A prewired harness with a plug-in module requires no headlamp wire splicing. The headlamps conform to Federal Motor Vehicle Safety Standards (FMVSS).

When the electrical plugs are connected, the vehicle headlamps will automatically switch to the snowplow headlamps when they are turned on. When the electrical plugs are disconnected, the headlamps will automatically switch to vehicle headlamps when they are turned on.

Replacement 2E1 Sealed Beam headlamps are available through your local FISHER® outlet.

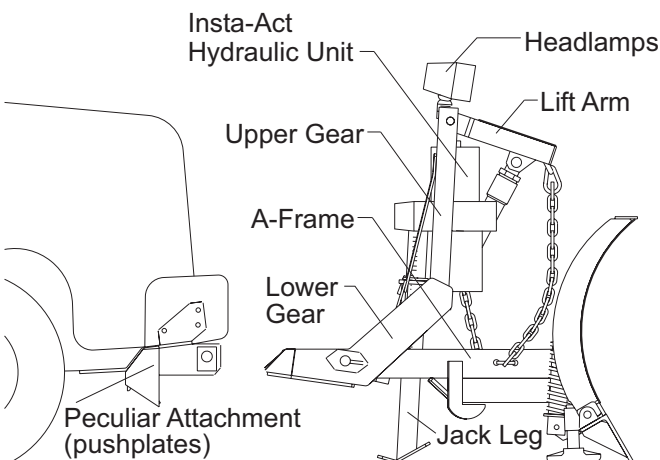

Insta-Act® HYDRAULIC UNIT

The Insta-Act Hydraulic Unit delivers a fast and uniform speed for lifting and angling. It raises the blade in approximately 3 seconds and angles side to side in approximately 6 seconds.

The Insta-Act Hydraulic Unit's angling gives you full control of the snowplow from within the cab. Two single-acting hydraulic rams hold the blade at the desired angle.

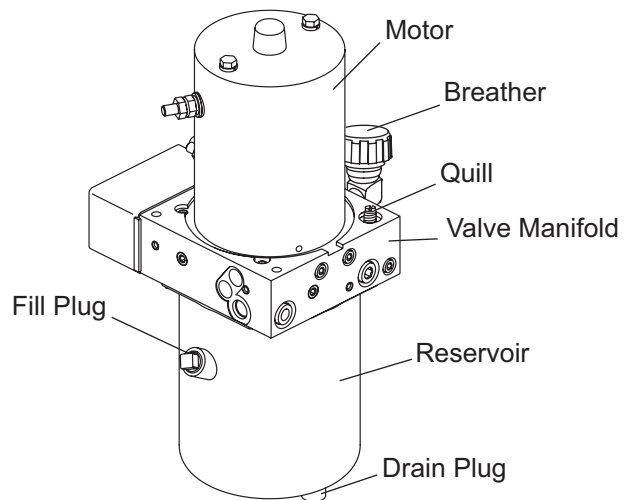

System Capacity

Insta-Act unit reservoir	1-3/4 quarts
Insta-Act system total	2-3/8 to 2-3/4 quarts

Pump Motor Specifications

12 volt DC with +/- connection
1700-1800 psi pump relief valve
2500-4050 psi angling relief valve
4.5" dia. 1.04 kw motor
.000477 GAL/REV Pump
Hydraulic Hose SAE 100R1

GETTING TO KNOW YOUR SNOWPLOW

CAB CONTROLS

⚠ WARNING

To prevent accidental movement of the blade, always turn the ON/OFF switch to OFF whenever the snowplow is not in use. The control indicator light will turn off.

The controls are electrically powered through the ignition (key) switch of your vehicle and are protected by a replaceable in-line fuse. The ON/OFF switch allows you to turn off the control and prevent blade movement even when the ignition is on. **The ON/OFF switch serves as an emergency stop when required.**

Joystick Solenoid Control

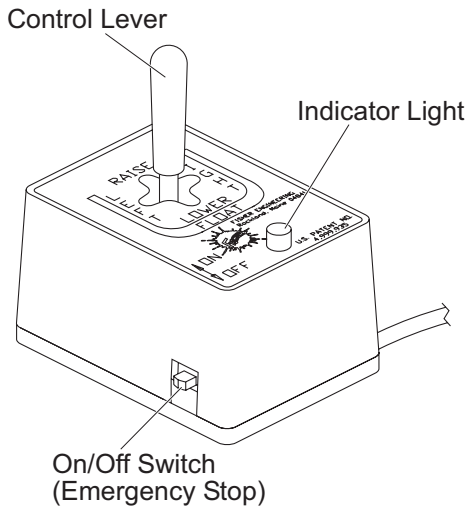

Fish-Stik® Hand-Held Control

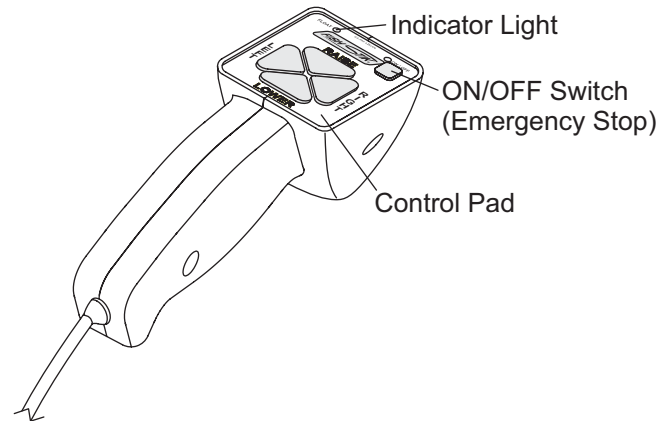

ACCESSORIES AND OPTIONS

SnoFoil® ASSEMBLY

A rigid curved extension attached to the top of your snowplow blade deflects light snow away from the windshield. It improves your plow's visibility, efficiency and speed. The SnoFoil Assembly bolts onto your existing blade and is available for 7', 7-1/2', 8', 8-1/2', 9' and 10' blades.

STEEL DEFLECTOR

Keeps fluffy snow from flowing over the top of the blade. It fits FISHER® LD and RD/HD Series blades. Easily installed and attractively priced.

RUBBER DEFLECTOR

Attaches to LD, RD/HD and MC Series blades. The flexible deflector keeps snow from flowing over the top of the blade. It is designed not to get damaged when encountering obstacles.

REPLACEABLE CARBON STEEL CUTTING EDGE

The cutting edges are made of high carbon steel and bolt onto the base angle for maximum blade life. Cutting edges are available for blades in 7-1/2', 8', 8-1/2', 9' and 10' sizes. Depending on the blade series, cutting edges are 3/8" or 1/2" thick.

REPLACEABLE POLYMER CUTTING EDGE

The 1"-thick cutting edges are made of durable polymer. They are lightweight and absorb most of the shock and vibration when the blade encounters rough surfaces. Designed for our LD Series blades, they are available in 6'9" and 7-1/2' lengths.

FISHER® EZ Flow HYDRAULIC FLUID

Improve the performance of your hydraulic systems, especially in extremely cold weather, with FISHER EZ Flow Hydraulic Fluid. Special antiwear and antifoaming additives keep your system running longer and smoother.

ANTIWEAR SHOES

These shoes offer maximum protection against blade wear. The more the blade is used, the more important the shoes become.

TOUCH-UP PAINT

FISHER touch-up paint is available to keep your snowplow protected from rust.

Minute Mount® SYSTEM SKID PLATES

These off-season inserts for the Minute Mount System pushplates offer protection by filling and covering the receiver portion of the pushplates. They also add to the vehicle's off-season appearance.



MOUNTING SNOWPLOW TO VEHICLE

MOUNTING SNOWPLOW

⚠ WARNING

Keep 8' clear of the blade drop zone when it is being raised, lowered or angled. Do not stand between the vehicle and blade or directly in front of blade. If the blade hits you or drops on you, you could be seriously injured.

⚠ CAUTION

Never use a finger to check an alignment. If the snowplow moves, your finger could be crushed.

NOTE: The blade must be in the straight position when mounting or removing the snowplow.

NOTE: Use dielectric grease to prevent corrosion on all connections.

Mounting Steps:

A.

1. Drive vehicle forward fully engaging pushplates into attachment arms.

B.

1. Twist connecting pin to release tension.
2. Remove electrical covers on vehicle.
3. Attach electrical connector to corresponding connector on vehicle.
4. Repeat steps B 1–3 on passenger side of vehicle.
5. Connect hydraulic hoses to quick disconnects. (BELT DRIVE ONLY)

C.

1. Release carrying chain and reattach it leaving plenty of slack.
2. Push headgear upward toward vehicle until connecting pins snap in place.
3. Pull jack lever outward and raise the jack stand.

NOTE: Adequate chain slack is necessary for connecting pin/hole alignment.

⚠ WARNING

Inspect snowplow components and bolts for wear or damage whenever mounting or removing the snowplow. Worn or damaged components could allow the snowplow to drop unexpectedly.

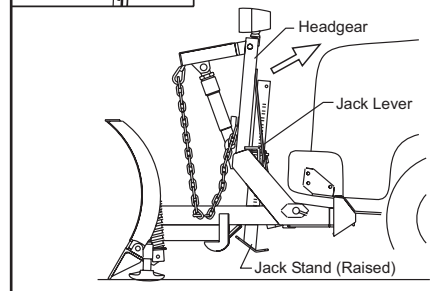
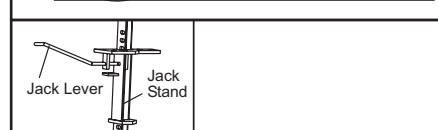
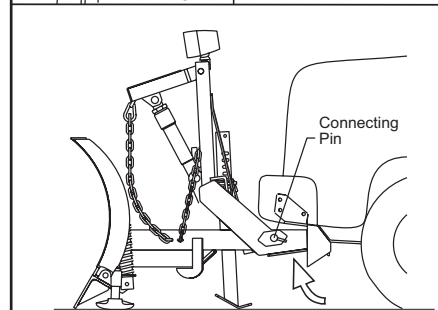
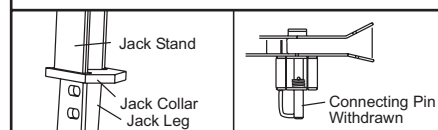
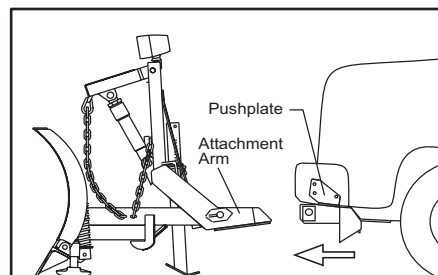

OPERATING YOUR SNOWPLOW

JOYSTICK SOLENOID CONTROL

⚠ WARNING

To prevent accidental movement of the blade, always turn the ON/OFF switch to OFF whenever the snowplow is not in use. The control indicator light will turn off.

⚠ CAUTION

DO NOT hold control lever in RAISE, ANGLE LEFT or ANGLE RIGHT position after blade has reached desired position. To do so will use excess current and overheat components.

Turn the vehicle ignition switch to the ON or the ACCESSORY position. Move control ON/OFF switch to the ON position. The control indicator light (red) lights when the control ON/OFF switch and the ignition (key) are both turned ON. **The ON/OFF switch operates as emergency stop when required.**

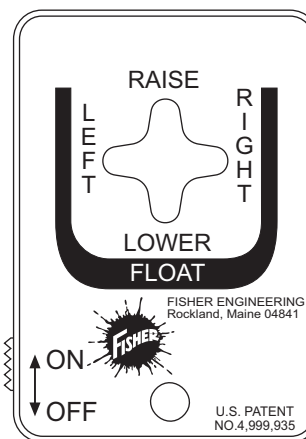

On/Off Switch
(Emergency Stop)

Action	Description of Operation
ON/OFF	Slide the control power switch ON to activate the hydraulic system. Turn the control OFF to lock the blade in place. This prevents accidental movement of the blade.
RIGHT	Move the control lever right to angle the blade to the right.
LEFT	Move the control lever left to angle the blade to the left.
RAISE	Move the control lever up (forward) to raise the blade to the desired height.
LOWER/FLOAT	Move the control lever down (back) to lower the blade and activate the float mode, which allows the blade to move up and down to follow the contour of the surface being plowed.
Cancel FLOAT	Cancel the float mode by momentarily placing the control in the RAISE position, turning the control off or turning the vehicle ignition off. Angling left or right does not cancel float.

OPERATING YOUR SNOWPLOW

Fish-Stik® HAND-HELD CONTROL

⚠ WARNING

To prevent accidental movement of the blade, always push button to switch the control OFF whenever the snowplow is not in use. The control indicator light will turn off.

1. Turn the vehicle ignition switch to the ON or the ACCESSORY position. The controller logo area illuminates.
2. Press the ON/OFF button on the control. The control indicator light glows red indicating the control is on. The control indicator light glows red whenever the control ON/OFF switch and the vehicle ignition switch are both ON. **The ON/OFF switch operates as emergency stop when required.**
3. Press the LOWER button for 0.75 seconds to engage the FLOAT mode. The control indicator FLOAT light glows green. Cancel the FLOAT mode by momentarily pressing the RAISE button.

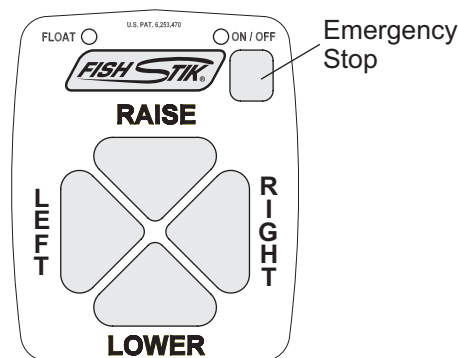

prevent unnecessary battery drain. The time-out period for the RAISE function is 4.8 seconds, while the angle function is 9.6 seconds.

Automatic Shutdown

The control automatically turns off after being idle for 20 minutes.

Smooth Stop

The control automatically allows the blade to coast to a stop. This results in smoother operation, reduces the shock to the hydraulic system and increases hose and valve life.

Function Time Outs

All control functions, except LOWER, automatically time out – stop – after a period of time. This helps

Button	Description of Operation
ON/OFF	Press this button to turn the control on and off. Turn the control off (power indicator light off) to lock the blade in place. This prevents accidental movement of the blade.
RIGHT	Press this button to angle blade to the right. NOTE: Plow automatically stops angling after 9.6 seconds.
LEFT	Press this button to angle blade to the left. NOTE: Plow automatically stops angling after 9.6 seconds.
RAISE	Press this button to raise the plow and to cancel the float mode. NOTE: Plow automatically stops raising after 4.8 seconds.
LOWER/ FLOAT	Press this button to lower the plow. NOTE: After reaching the desired height, release the button. Holding the button down for more than 0.75 seconds activates the float mode, indicated by green FLOAT light. The float mode allows the blade to move up and down to follow the contour of the surface being plowed.
Cancel FLOAT	Cancel the float mode by pressing the RAISE button, turning control off or turning vehicle ignition off. Angling left or right momentarily cancels float.

OPERATING YOUR SNOWPLOW

SNOWPLOW HEADLAMP CHECK

With all electrical plugs connected, check the operation of vehicle and snowplow headlamps.

Lights	Results
Parking Lamps	Both vehicle and snowplow lamps should be on.
Right Turn Signal	Both vehicle and snowplow lamps should be on.
Left Turn Signal	Both vehicle and snowplow lamps should be on.

Connecting and disconnecting the electrical plugs should switch between the vehicle and snowplow headlamps as follows:

- Electrical plugs DISCONNECTED – The vehicle headlamps should light up.
- Electrical plugs CONNECTED – The snowplow headlamps should light up.

Aiming the Headlamps

- Aim the snowplow headlamps with the snowplow mounted and raised in the transport position. See Aiming Headlamp Beams in the Maintenance section for instructions.
- Aim the vehicle headlamps with the snowplow removed from the vehicle.

ANTIWEAR SHOE ADJUSTMENT

⚠ WARNING

Blade can drop unexpectedly. Place blade on jack stands. Failure to do so could result in serious personal injury.

⚠ CAUTION

Do not store unused spacers on top of the shoe holder. This could damage the blade.

Recommended Shoe Adjustments

For gravel surfaces: The bottom surface of the shoe should be 1/4" to 1/2" below the cutting edge.

For hard surfaces (concrete or asphalt): The bottom surface of the shoe should be even with the cutting edge.

Adjustment Procedure

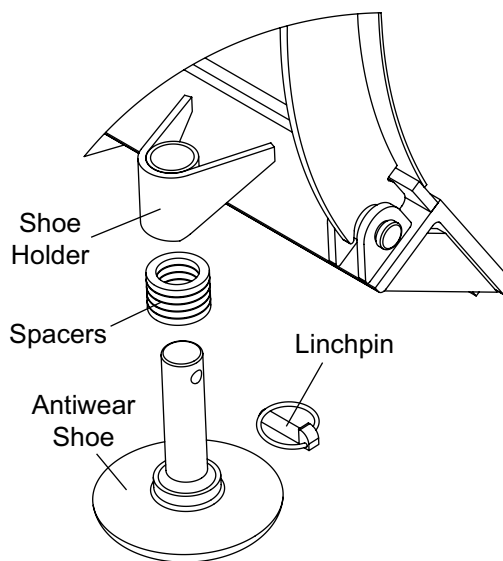

1. Raise the blade 1' off the road surface, turn the control to the OFF position, and from in front of the blade, place jack stands or sturdy blocking under the cutting edge.
2. Turn the control to the ON position, and lower the blade onto the jack stands or blocking. Turn the control and the vehicle ignition to the OFF position.
3. Remove the linchpin, and slide the antiwear shoe down and out of the shoe holder.
4. Remove one or more spacers from the shoe stem, and reinstall the shoe into the shoe holder.
5. Reinstall the linchpin.
6. Turn the vehicle ignition to the ON position, and turn the control to the ON position. Raise the blade slightly from the jack stands. Turn the control to the OFF position, and remove the jack stands.
7. Stand 8' clear of the blade drop zone when checking the height adjustment of the cutting edge to the road surface.
8. Do not store unused spacers on top of the shoe holder.

OPERATING YOUR SNOWPLOW

HYDRAULIC SYSTEM

The Insta-Act® Hydraulic Unit's valve manifold includes two cushion valves to prevent damage to the blade or vehicle if an obstacle is hit at either end of the blade. When force against the blade causes the pressure **in an extended ram** to exceed set limits, the cushion valve opens allowing fluid to escape and the ram retracts. Fluid from the retracting ram flows into the opposite angle ram as it extends.

Fluid Level

Push lift arm all the way down with the Minute Mount® system attached to the vehicle. Remove the fill plug. Fill reservoir through the fill plug hole until reservoir is full. Replace fill plug. For hydraulic fluid type and filling instructions, see Hydraulic System, Annual Fluid Change, in the Maintenance section of this manual.

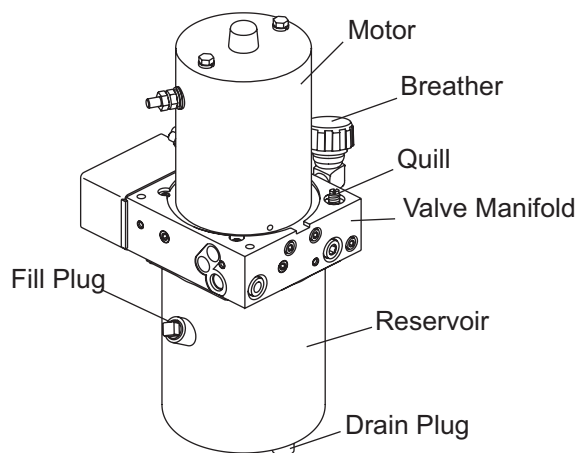

BLADE DROP SPEED ADJUSTMENT

⚠ WARNING

Keep 8' clear of the blade drop zone when it is being raised, lowered or angled. Do not stand between the vehicle and blade or directly in front of blade. If the blade hits you or drops on you, you could be seriously injured.

The quill in the top of the valve manifold adjusts the blade drop speed.

1. Lower the blade to the ground before making adjustment.

2. Turn the quill IN (clockwise) to decrease drop speed. Turn the quill OUT (counterclockwise) to increase drop speed.
3. Stand 8' clear of the blade drop zone when checking adjustment.

TRANSPORTING SNOWPLOW

⚠ WARNING

**Position blade so it does not block headlamp beam.
Do not change blade position while traveling.
You could suddenly lower blade accidentally.**

⚠ CAUTION

**Transport speed should not exceed 45 mph.
Reduce speed under adverse travel conditions.**

⚠ CAUTION

Remove slack from carrying chain before traveling.

These instructions are for driving short distances to and from plowing jobs. Remove the snowplow from the vehicle for long trips and place in pickup box. The lift arm hook can be used as an attaching point to lift and move the snowplow following recommended mechanical lifting cautions and procedures.

1. Completely raise the blade.
2. Adjust the blade height for maximum snowplow headlamp illumination.
3. Adjust the blade to the straight position.
4. Move the control ON/OFF switch to OFF to lock blade in place.

NOTE: Overheating is unlikely under normal driving conditions, but occasionally the snowplow may be positioned where it deflects air away from the radiator. If this occurs, stop the vehicle and raise, lower or angle the snowplow slightly to correct overheating.

NOTE: Only the driver should be in the vehicle cab when the snowplow is attached.

OPERATING YOUR SNOWPLOW

DRIVING AND PLOWING ON SNOW AND ICE

⚠ CAUTION

Drinking then driving or plowing is very dangerous. Your reflex, perceptions, attentiveness and judgement can be affected by even a small amount of alcohol. You can have a serious or even fatal collision if you drive after drinking. Please, do not drink and then drive or plow.

Refer to vehicle owner's manual instructions for driving in snow and ice conditions. Remember when you drive on snow or ice, your wheels will not get good traction. You cannot accelerate as quickly, turning is more difficult and you will need longer braking distance.

Wet and hard packed snow or ice offers the worst tire traction. It is very easy to lose control. You will have difficulty accelerating. If you do get moving, you may have poor steering and difficult braking which can cause you to slide out of control.

Here are some tips for driving in these conditions:

- Drive defensively.
- Do not drink, then drive or plow snow.
- Plow or drive only when you have good visibility for operating a vehicle.
- If you cannot see well due to snow or icy conditions, you will need to slow down and keep more space between you and other vehicles.
- Slow down, especially on higher speed roads. Your headlamps can light up only so much road ahead.
- If you are tired, pull off in a safe place and rest.
- Keep your windshield and all glass on your vehicle clean to see around you.
- Dress properly for the weather. Wear layers of clothing, as you get warm you can take off layers.

PLOWING SNOW

⚠ WARNING

Never plow snow with head out the vehicle window. Sudden stops or protruding objects could cause personal injury.

⚠ CAUTION

Wear a seatbelt when plowing snow. Hidden obstructions could cause the vehicle to stop suddenly resulting in personal injury.

⚠ CAUTION

Flag any obstructions that are hard to locate under snow to prevent damage to product or property.

⚠ CAUTION

Never stack snow with the blade angled. This could damage the snowplow or the vehicle bumper.

⚠ CAUTION

Plowing speed should not exceed 10 mph.

NOTE: Only the driver should be in the vehicle cab when the snowplow is attached.

General Instructions

1. Before plowing, make sure you know of any obstructions hidden beneath the snow such as: bumper stops in parking lots, curbs, sidewalk, shrubs, fences or pipes sticking up from the ground. If unfamiliar with the area to be plowed, have someone familiar with the area point out obstacles.
2. If possible and you have good visibility, plow during the storm rather than letting snow accumulate.
3. Do not exceed 10 mph (16 kph) when plowing snow.
4. When you are stacking snow, begin raising the blade as you come close to the stack. This will let the blade ride up the stack.

OPERATING YOUR SNOWPLOW

Hard-packed Snow

1. On blades equipped with a shoe kit, raise the antiwear shoes so that the cutting edge comes into direct contact with the pavement. **Do not stack spare spacers on top of shoe holder.**
2. Use lowest gear to place maximum power behind cutting edge.
3. An angled blade is more effective for removing hard-packed snow.

Deep Snow

1. Shear off top layers by plowing with the blade raised 3 to 4 inches for the initial pass.
2. Bite into the edges using only partial blade width until job is cut down to size for full blade plowing.

Rule of thumb:

- 6" of snow — plow with entire blade width;
- 9" of snow — plow with 3/4 blade width; and
- 12" of snow—plow with 1/2 of the blade.

Experience and "feel" are the best guides.

3. When plowing deep snow, be sure to keep vehicle moving.
4. Ballast is suggested for maximum traction. Secure ballast behind the rear wheels. Do not exceed vehicle's GVWR and GAWR.
5. For increased traction use tire chains where legal.

Clearing Driveways

1. Head into the driveway with the blade angled and plow the snow away from any buildings. Widen driveway by rolling snow away from any buildings.
2. If a building is at the end of the driveway, plow to within a vehicle length of the building. Push as much snow as possible off the driveway.
3. With a raised blade, drive through remaining snow to building. Drop blade and "back-drag" snow away from the building at least one vehicle length. Repeat if necessary.
4. Back vehicle to the building and plow forward, removing the remaining snow from the driveway. Check municipal ordinances for proper disposal of snow.

Clearing Parking Lots

1. Clear areas in front of buildings first. With blade raised, drive up to the building. Drop blade and "back-drag" the snow away from building. When snow is clear of the buildings, turn the vehicle around and push snow away from the buildings towards outer edges of lot.
2. Plow a single path down the center in the lengthwise direction.
3. Angle the snowplow towards the long sides, and plow successive strips lengthwise until the area is cleared and snow is "stacked" around the outer edges.
4. If snow is too deep to clear in above manner, clear main traffic lanes as much as possible.

PARKING WITH SNOWPLOW ATTACHED

WARNING

Lower blade when vehicle is parked. Keep 8' clear of blade drop zone. Temperature changes could change hydraulic pressure, causing the blade to drop unexpectedly or damaging hydraulic components. Failure to do this can result in serious personal injury.

Whenever you park your vehicle, completely lower the blade to the ground.

TOWING DISABLED OR STUCK VEHICLE

Do not use any snowplow components as an attaching point when retrieving, towing, or winching a disabled or stuck vehicle.

REMOVING SNOWPLOW AND STORAGE

REMOVING SNOWPLOW

⚠ WARNING

Keep 8' clear of the blade drop zone when it is being raised, lowered or angled. Do not stand between the vehicle and blade or blade or directly in front of blade. If the blade hits you or drops on you, you could be seriously injured.

⚠ CAUTION

Never use a finger to check an alignment. If the snowplow moves, your finger could be crushed.

⚠ WARNING

Inspect snowplow components and bolts for wear or damage whenever mounting or removing the snowplow. Worn or damaged components could allow the snowplow to drop unexpectedly.

⚠ CAUTION

Never pull jack lever when blade assembly is not attached to vehicle. The headgear assembly will suddenly drop.

NOTE: The blade must be in the straight position when mounting or removing the snowplow.

During the off-season, the control can be removed. Disconnect the connector in the cab and store the control in the glovebox of the vehicle.

Removing Steps:

A.

1. Place cab control in "Lower/Float".
2. Push lift arm down.
3. Pull jack lever outward. Jack stand will adjust to proper height.

B.

1. Disconnect electrical connector and reinsert in protective cover.
2. Insert release rod under jack collar.
3. Push down on release rod as you pull and twist connecting pin.
4. Repeat steps B 1–3 on passenger side.
5. Disconnect hydraulic hose couplings and cover with dust plugs.

C.

1. Remove slack from carrying chain and reattach.
2. Back vehicle away from plow.

NOTE: The function of the release rod is to relieve pressure on the connecting pins. Use only enough downward pressure on the rod end to effect release of the pins.

NOTE: After each disconnection of the snowplow, reapply dielectric grease to the electrical plugs to maintain the protective coating on the terminals.

NOTE: Place electrical plugs in storage position. On the snowplow, connect control and lighting electrical plugs together. Insert battery cable into boot. On the vehicle, connect control and lighting electrical plugs together. Cover battery cable with attached boot.

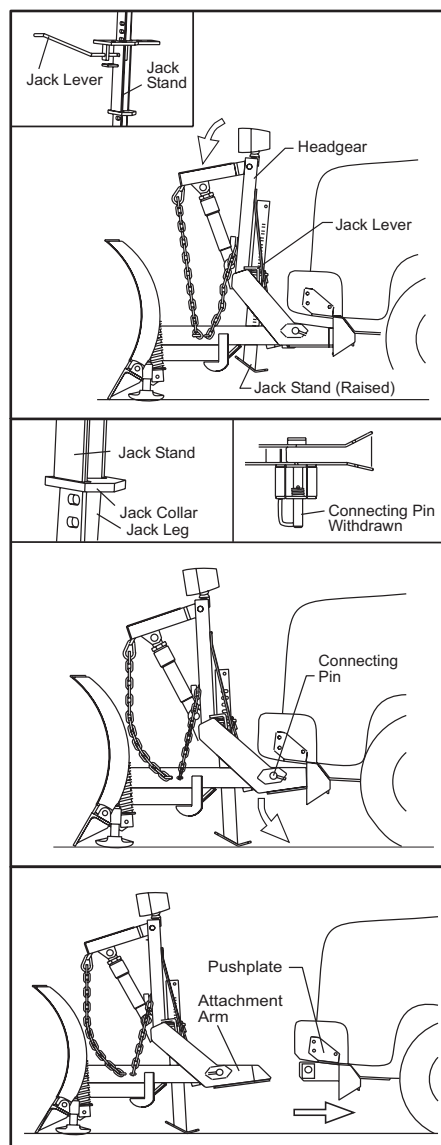

REMOVING SNOWPLOW AND STORAGE

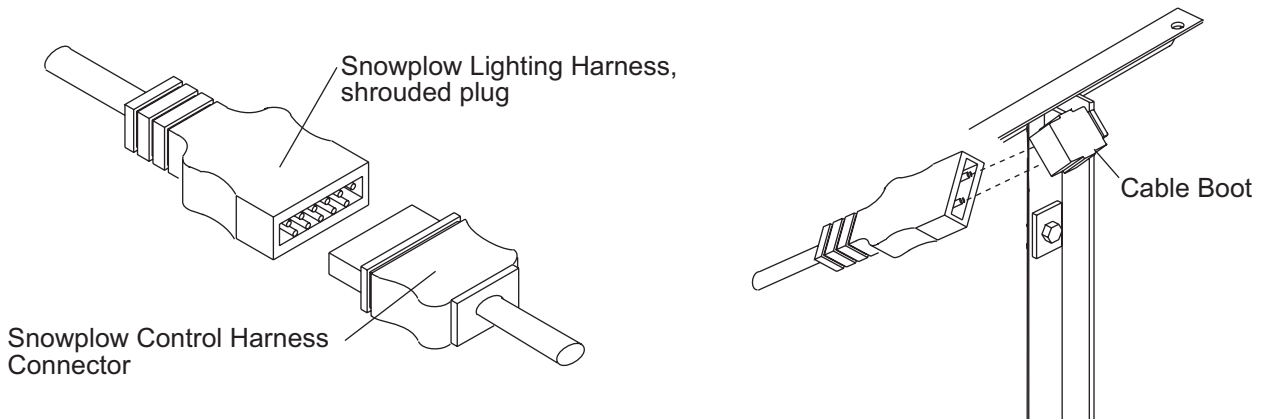
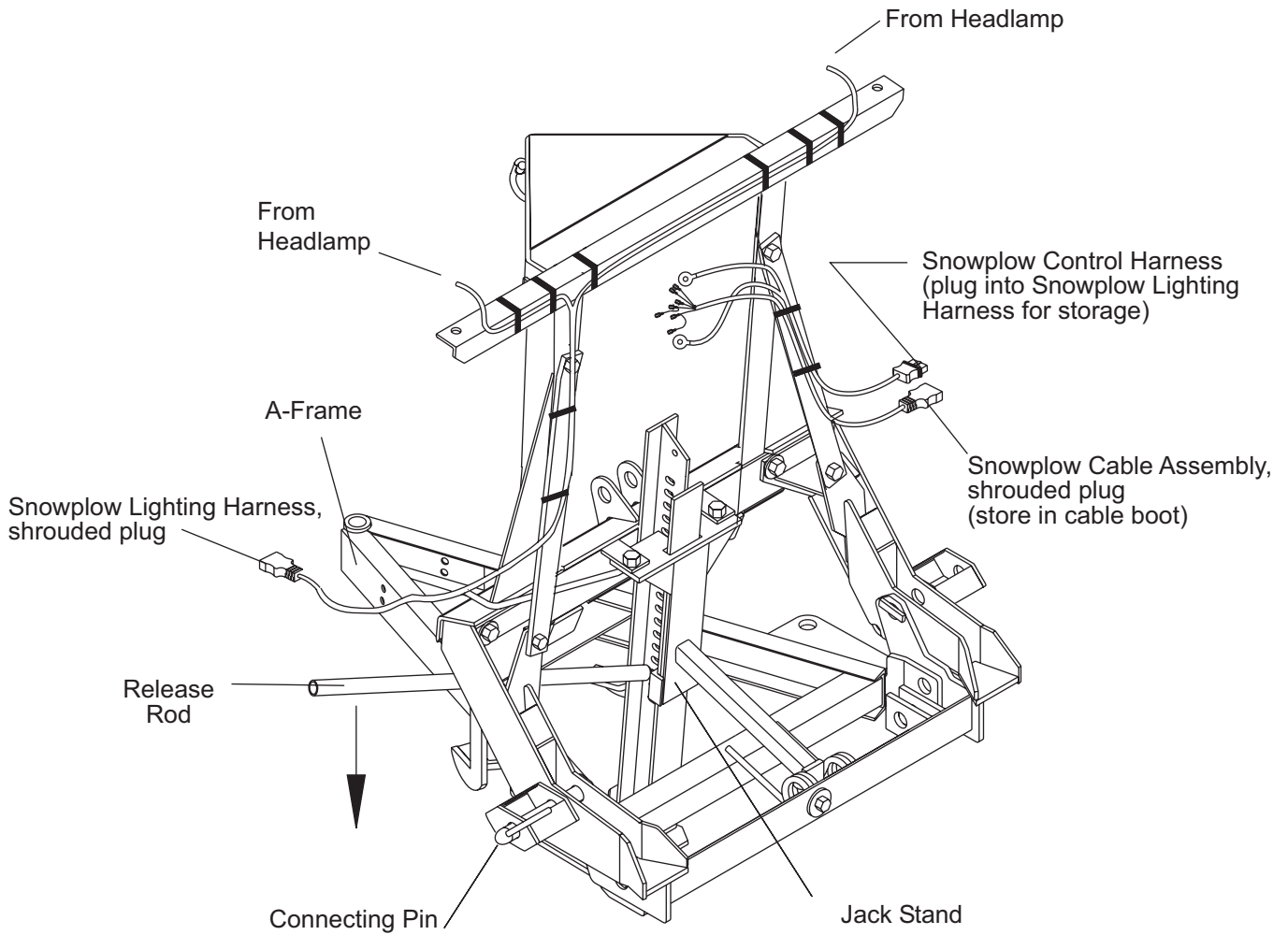

MAINTENANCE

AIMING HEADLAMP BEAMS

Torque headlamp fasteners to 45 ft-lb once correct visual aim is achieved.

1. Place vehicle on a level surface 25 feet in front of a matte-white screen, such as a garage door. The screen should be perpendicular both to the ground and to the vehicle centerline.
2. The vehicle should be equipped for normal operation. The snowplow blade should be in place and in raised position. Below are steps listed by the Society of Automotive Engineers (SAE) pertinent to headlamp aiming in specification #SAE J599d.
3. Prepare vehicle for headlamp aim or inspection. Before checking beam aim, the inspector will:
 - a. Remove ice or mud from under fenders.
 - b. Set tire inflation pressures to the values specified on vehicle information label.
 - c. Check springs for sag or broken leaves.
 - d. See that there is no load in the vehicle other than the driver and ballast as specified in the Kit Selection Guide.
4. Mark (or tape) the vertical centerline of the snowplow headlamps and the vertical centerline of the vehicle on the screen. Mark the horizontal centerline of the snowplow headlamps on the screen (distance from ground to snowplow headlamp centers).
5. Align the top edge of the high intensity zone of the snowplow lower beam below the horizontal centerline and the left edge of the high intensity zone on the vertical centerline for each snowplow headlamp. (Refer to diagram below.)

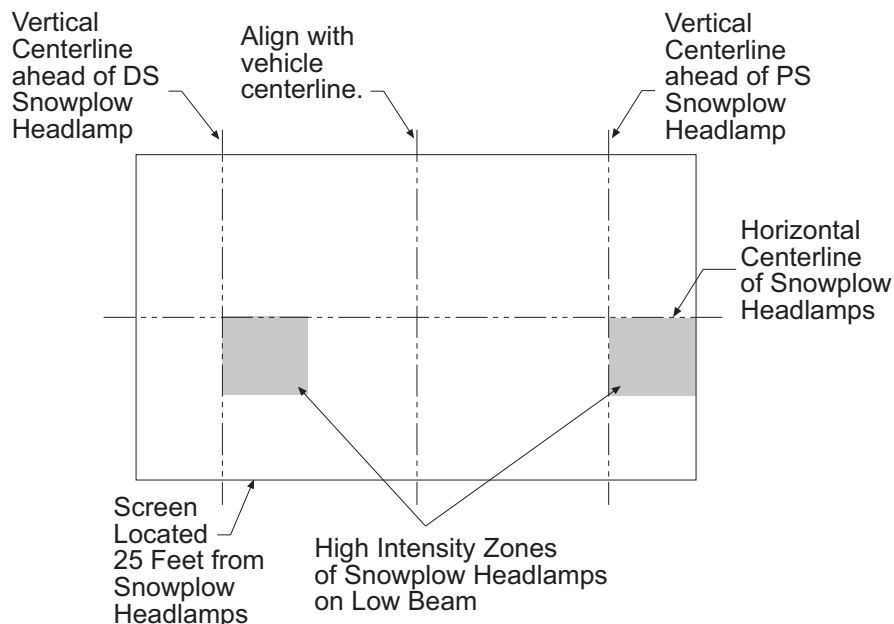

MAINTENANCE

PRESEASON CHECK

⚠ WARNING

Lower blade when vehicle is parked. Keep 8' clear of blade drop zone. Temperature changes could change hydraulic pressure, causing the blade to drop unexpectedly or damaging hydraulic components. Failure to do this can result in serious personal injury.

Before the snow season, check your equipment to make sure it's in working condition. Here are some tips for getting your equipment ready:

- Clean and tighten all electrical connections and coat with dielectric grease to prevent corrosion.
- Check hydraulic system for leaks and cracked or damaged hoses.
- Drain hydraulic system and refill with recommended hydraulic fluid. For hydraulic fluid type and filling instructions, see Hydraulic System, Annual Fluid Change, in this section of the manual.
- Replace worn or defective parts.
- Check all mounting points and tighten fasteners, on both snowplow and vehicle.
- Repaint blade assembly and attachments, as necessary, to protect the metal.
- Install auxiliary and flashing lights for compliance and visibility in accordance with local regulations.
- Check headlamps, auxiliary lights, heater and windshield wipers for proper operation.
- Inspect and test your battery. Recharge or replace as necessary.
- Ballast may be necessary, or beneficial, on some vehicles to provide maximum traction, braking and handling.
- Any ballast material (such as sand and blocks) must be solidly secured to the vehicle preventing it from moving under harsh plowing conditions.

POSTSEASON MAINTENANCE

⚠ CAUTION

Servicing the trip springs without special tools and knowledge could result in personal injury. See your authorized FISHER outlet for service.

NOTE: Coat all electrical connections with dielectric grease.

- Clean and paint blade and attachments as needed.
- Be sure lift ram is collapsed so the rod is not exposed.
- Coat angle ram rods with general purpose petroleum grease.
- Lubricate all pivot points (for example, connecting pin assembly and lower spring anchor) with general purpose petroleum grease.

MAINTENANCE AND ADJUSTMENT

⚠ WARNING

Lower blade when vehicle is parked. Keep 8' clear of blade drop zone. Temperature changes could change hydraulic pressure, causing the blade to drop unexpectedly or damaging hydraulic components. Failure to do this can result in serious personal injury.

Your FISHER® snowplow is designed for rugged, dependable service. Though, like the vehicle on which it is mounted, it needs regular care and maintenance.

Check that all fasteners, mounting bolts, hydraulic and electrical connections are tight before each storm and frequently throughout season. Also check all plugs and seals for leaks. Repair as necessary.

Lubricate all moving parts for ease of operation. Not doing so will make operating of the mount difficult and possibly damage components.

LIFTING

The lift arm hook can be used as an attaching point to lift and move this snowplow following recommended mechanical lifting cautions and procedures.

MAINTENANCE

HYDRAULIC SYSTEM

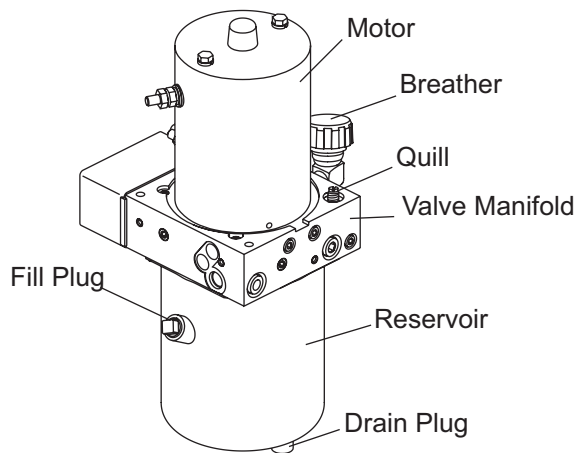

Fluid Level

⚠ CAUTION

Do not mix different types of hydraulic fluid. Some fluids are not compatible and may cause performance problems and product damage.

With lift ram rod fully retracted remove the fill plug. Fill reservoir through the fill plug hole until reservoir is full. Replace fill plug.

Annual Fluid Change

⚠ CAUTION

Change the fluid at the beginning of each plowing season. Failure to do this could result in condensation buildup during the non-snowplow season.

⚠ CAUTION

Do not mix different types of hydraulic fluid. Some fluids are not compatible and may cause performance problems and product damage.

1. Perform this operation with the plow attached to the truck on a hard level surface.
2. Lower blade to ground.

3. Activate control float function and manually collapse lift ram all the way. Turn control off.
4. Remove drain plug located in the bottom of the hydraulic reservoir.
5. Completely drain reservoir and replace drain plug.
6. Remove the angle ram hoses from the fittings on the hydraulic unit and place in a drain pan or suitable container. **(See illustration below and Hydraulic Hose or Fitting Replacement instructions.)**

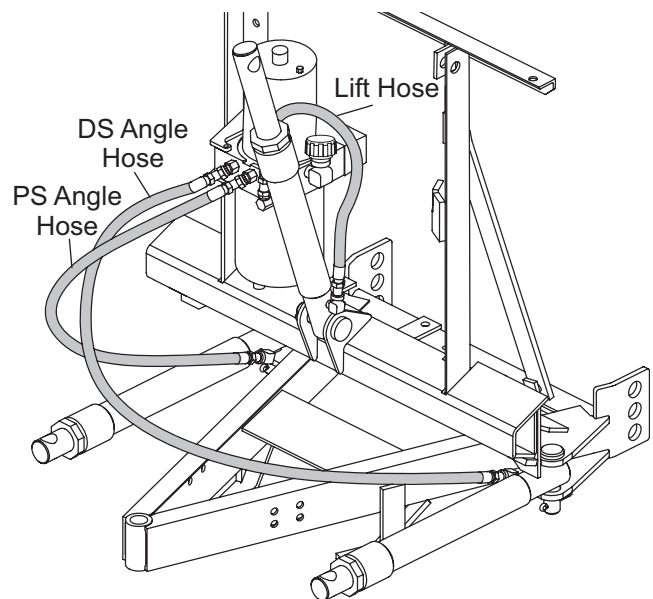

7. Manually angle the blade fully in each direction to remove fluid from the angle rams. Do not allow hose from the extending ram to take fluid back in.
8. Reconnect the angle ram hoses to the proper fittings. **(See illustration above and Hydraulic Hose or Fitting Replacement instructions.)**

⚠ WARNING

Keep 8' clear of the blade drop zone when it is being raised, lowered or angled. Do not stand between the vehicle and blade or directly in front of blade. If the blade hits you or drops on you, you could be seriously injured.

MAINTENANCE

⚠ CAUTION

Do not raise blade during fill process as this may cause pump cavitation.

9. Fill reservoir to fill plug level with FISHER® EZ Flow Hydraulic Fluid to -40°F (-40°C), or other fluid conforming to Military Specification MIL-H-5606A, such as Mobil Aero HFA or Shell AeroShell® Fluid 4.

Replace fill plug.

10. Activate control and angle blade fully to the left and right several times to remove air from the angle rams.
11. Turn off control and refill reservoir to fill plug level. Replace fill plug.
12. Activate control and raise and lower plow several times to remove air from lift ram. Activate float function and manually collapse lift ram all the way after each lowering of the blade.
13. Recheck fluid level with lift ram fully collapsed.

⚠ WARNING

To prevent accidental movement of the blade, always turn the ON/OFF switch to OFF whenever the snowplow is not in use. The control indicator light will turn off.

Packing Nut Adjustment

⚠ CAUTION

Do not overtighten the packing nut. Overtightening affects operation and shortens the life of the packing.

Periodically check lift and angle ram packing nuts to see if they have loosened. If loose, or leakage appears while lifting or angling, tighten not more than 1/4-turn after you feel packing nut contact the packing. Packing not used for a period of time may show signs of fluid weep. This usually disappears after use.

Lift ram packing may dry out, making it difficult to completely lower the lift arm. In this case, loosen packing nut, lubricate rod, and work rod in and out using cab control. Snug packing nut when movement is restored.

Hose or Fitting Replacement

DO NOT use thread sealant/tape on hoses or fittings. This could damage product. Follow recommended replacement procedures for fittings and hoses.

⚠ WARNING

Lower blade when vehicle is parked. Keep 8' clear of blade drop zone. Temperature changes could change hydraulic pressure, causing the blade to drop unexpectedly or damaging hydraulic components. Failure to do this can result in serious personal injury.

1. Turn off control.
2. Loosen hoses or fittings slowly to bleed off any residual pressure.
3. To remove a hose, loosen and unscrew the hose flare nut from the fitting.
4. To remove a fitting, loosen the jam nut and unscrew the fitting from the port.

MAINTENANCE

Procedure for Installing Hydraulic Fittings and Hoses

NOTE: Over torquing JIC hose fitting ends will result in a fractured fitting.

DO NOT use any type of sealant or tape on the fittings or hoses. This could damage product. Always use two wrenches to ensure proper tightening of fittings and hoses.

Use the following procedure to install SAE o-ring fittings in valve block and rams.

1. Turn jam nut on fitting as far back as possible.
2. Lubricate O-ring with clean hydraulic fluid.
3. Screw fitting into port by hand until the washer contacts port face and shoulder of the jam nut threads.
4. Unscrew fitting to proper position no more than one full turn.
5. Using two wrenches, hold fitting body in position and tighten jam nut until the washer again contacts port face, then tighten an additional 1/8 to 1/4 turn to lock fitting in place. Final torque on the jam nut should be approximately 20 ft-lb.

Use the following procedure to install hydraulic hoses.

1. Screw flare nut onto fitting flare and hand tighten.
2. Align hose so there are no twists or sharp bends.
3. Using two wrenches, hold the hose in position and tighten flare nut 1/8 to 1/4 turn beyond hand tight. Final torque on the flare nut should be approximately 20 ft-lb.

Pump Inlet Filter Screen

Clean the pump inlet filter screen whenever the pump is removed. Replace the screen if it is damaged. Torque the die cast pump mounting cap screws to 150-160 in-lb.

VEHICLE

The snowplow operating vehicle shall be maintained according to manufacturer's recommendations. Tire pressure shall be maintained according to manufacturer's recommendation.

RECYCLE

When your snowplow has performed its useful life, the majority of its components can be recycled as steel or aluminum. Hydraulic fluid shall be disposed according to local regulations. Balance of parts made of plastic shall be disposed in customary manner.

EMERGENCY PARTS / TOOLS

- 2 – 10" Adjustable Wrenches
- 1 – Medium Screwdriver
- 1 – Pair of Pliers
- 1 – #20 TORX® Driver / 1/4" socket
- 7.5, 10, 15 Amp ATC fuses
- Funnel
- Test Light
- Flashlight
- 1/8" Allen Wrench
- 1/4" Ratchet, 6" Extension, 5/16" Socket
- Electrical Tape
- 1 – Quart FISHER® EZ Flow Hydraulic Fluid



TROUBLESHOOTING GUIDE

Some of the following guide corrections listed here are complicated. Unless you are very experienced in electrical and hydraulic repair, let your trained FISHER® outlet service personnel do the repairs.

Condition	Possible Cause	Correction
Control power indicator not on	Control not turned on.	Turn on control.
	No power to control.	Blown fuse. Part of the FISHER® vehicle control harness. Replace fuse.
	Plow/vehicle lighting harness not connected.	Properly connect both harnesses.
Motor does not run	Plow/vehicle control harnesses not connected.	Properly connect both harnesses.
	Blown fuse in FISHER vehicle control harness.	Replace blown fuse in control harness.
	Control malfunction or fault in wiring.	See FISHER outlet for repair information.
Motor will not shut off	Motor relay or control malfunction or fault in wiring.	See FISHER outlet for repair information.
Snowplow won't raise or raises slowly or partially	Excess weight on blade.	Remove snow and/or ice buildup or aftermarket accessories (excess weight).
	Hydraulic fluid level low or wrong fluid is used.	Fill reservoir to proper level with recommended fluid. Do not mix different hydraulic fluid types.
	Lift ram packing nut too tight.	Loosen and retighten packing nut according to the procedure.
	Vehicle battery weak or charging system defective.	Replace battery and check charging system.
	Motor worn or damaged or fault in wiring.	See FISHER outlet for repair information.
	Pump filter clogged, worn or damaged pump, or hydraulic system malfunction.	See FISHER outlet for repair information.
Snowplow angles slowly or partially	Hydraulic fluid level low or wrong fluid is used.	Fill reservoir to proper level with recommended fluid. Do not mix different hydraulic fluid types.
	Vehicle battery weak or charging system defective.	Replace battery and check charging system.
	Air trapped in angle rams.	Cycle per procedure to remove air from rams.
	Angle rams damaged.	See FISHER outlet for repair information.
	Motor worn or damaged, or fault in wiring.	See FISHER outlet for repair information.
	Pump filter clogged, worn or damaged pump, or hydraulic system malfunction.	See FISHER outlet for repair information.

TROUBLESHOOTING GUIDE

Condition	Possible Cause	Correction
Snowplow won't lower, lowers slowly, or won't float	Hydraulic fluid not correct for outside temperature.	Use recommended fluid.
	Lift ram packing nut too tight.	Adjust lift ram packing nut. Loosen and retighten according to the procedure.
	Blown fuse in FISHER [®] vehicle control harness.	Replace blown fuse.
	Control or hydraulic system malfunction or fault in wiring.	See FISHER outlet for repair information.
Snowplow lowers by itself or won't stay in raised position	Lift ram packing nut loose. (external leakage apparent)	Tighten ram packing nut according to the procedure.
	Hydraulic fittings or hoses loose or damaged.	Tighten or replace components or see FISHER outlet for repair information.
	Control or hydraulic system malfunction.	See FISHER outlet for repair information.
Snowplow does not perform the selected function or performs a different function	Hydraulic hose routing incorrect.	See FISHER outlet for repair information.
	Control or hydraulic system malfunction, or fault in wiring.	See FISHER outlet for repair information.
Fluid leaks from hydraulic system	Reservoir overfilled.	Do not fill reservoir beyond filler plug.
	Failed seal/O-ring.	See FISHER outlet for repair information.
	Loose or damaged hydraulic fittings, hoses, plugs, or hardware.	Tighten loose components. See FISHER outlet for repair information.
Fluid leaks from angle or lift ram	Lift ram packing nut loose.	Adjust ram packing nut.
	Hydraulic fittings or hoses loose or damaged.	Tighten or replace components or see FISHER outlet for repair information.
	Angle or lift rams damaged.	See FISHER outlet for repair information.
Fuse in FISHER control harness blown	Motor relay or control malfunction, or fault in wiring.	See FISHER outlet for repair information.
Vehicle fuse blows	Circuit overloaded, or fault in wiring.	See FISHER outlet for repair information.
Excessive load on vehicle electrical system while using snowplow	Hydraulic fluid not correct for outside temperature.	Use recommended fluid.
	Lift and/or angle ram packing nut too tight.	Adjust ram packing nut.
	Vehicle battery weak or charging system defective.	Replace battery and check charging system.
	Worn or damaged motor or pump, or fault in wiring.	See FISHER outlet for repair information.
	Vehicle electrical system inadequate.	Check vehicle specifications and FISHER recommendations.

TROUBLESHOOTING GUIDE

Condition	Possible Cause	Correction
Snowplow headlamps operate irregularly or not at all (plow attached).	Plow and vehicle lighting harnesses are not mated correctly.	Properly connect both harnesses.
	Burned out bulbs or corroded sockets.	Replace bulbs, clean contacts.
	Isolation Module not operating or fault in wiring.	See FISHER [®] outlet for repair information.
Vehicle headlamps operate irregularly or not at all, with snowplow removed.	Burned out bulbs.	Replace bulbs.
	Defective vehicle fuse.	Replace fuse.
	Fault in peculiar harness wiring.	See FISHER outlet for repair information.
Vehicle daytime running lights (DRL) do not work with snowplow removed.	Parking brake on. Gear Selector not in drive. Vehicle light sensor has activated headlamps.	Fully release parking brake.
	Power or DRL circuit has been interrupted.	Turn on light and/or ignition switch to cycle the DRL circuitry.
Plow park/turn lamps not operating.	Blown fuse. Part of the FISHER vehicle control harness.	Replace fuse.
Vehicle battery loses charge when snowplow is not being used.	Vehicle battery weak.	Replace battery.
	Wiring fault.	See FISHER outlet for repair information.
A separate <i>Mechanic's Guide</i> is available. Contact your FISHER outlet for more details.		



Fisher Engineering
P.O. Box 529
Rockland, ME 04841



 A DIVISION OF DOUGLAS DYNAMICS, L.L.C.

Copyright © 2005 Douglas Dynamics, L.L.C. All rights reserved. This material may not be reproduced or copied, in whole or in part, in any printed, mechanical, electronic, film or other distribution and storage media, without the written consent of Fisher Engineering. Authorization to photocopy items for internal or personal use by Fisher Engineering outlets or snowplow owner is granted.

Fisher Engineering reserves the right under its product improvement policy to change construction or design details and furnish equipment when so altered without reference to illustrations or specifications used. Fisher Engineering and the vehicle manufacturer may require and/or recommend optional equipment for snow removal. Do not exceed vehicle ratings with a snowplow. This product is manufactured under the following U.S. patents: 4,999,935; 5,353,530; 5,420,480; 6,253,470; RE35700; CAN patent 2,060,425 and other patents pending. Fisher Engineering offers a limited warranty for all snowplows and accessories. See separately printed page for this important information. The following are registered (®) trademarks of Douglas Dynamics, L.L.C.: FISHER®, Fish-Stik®, Insta-Act®, Minute Mount®, SnoFoil®.

Printed in U.S.A.