



Fisher Engineering

P.O. Box 529 Rockland, Maine 04841

26020

April 15, 1999

No. 26416

Mini Bar Light

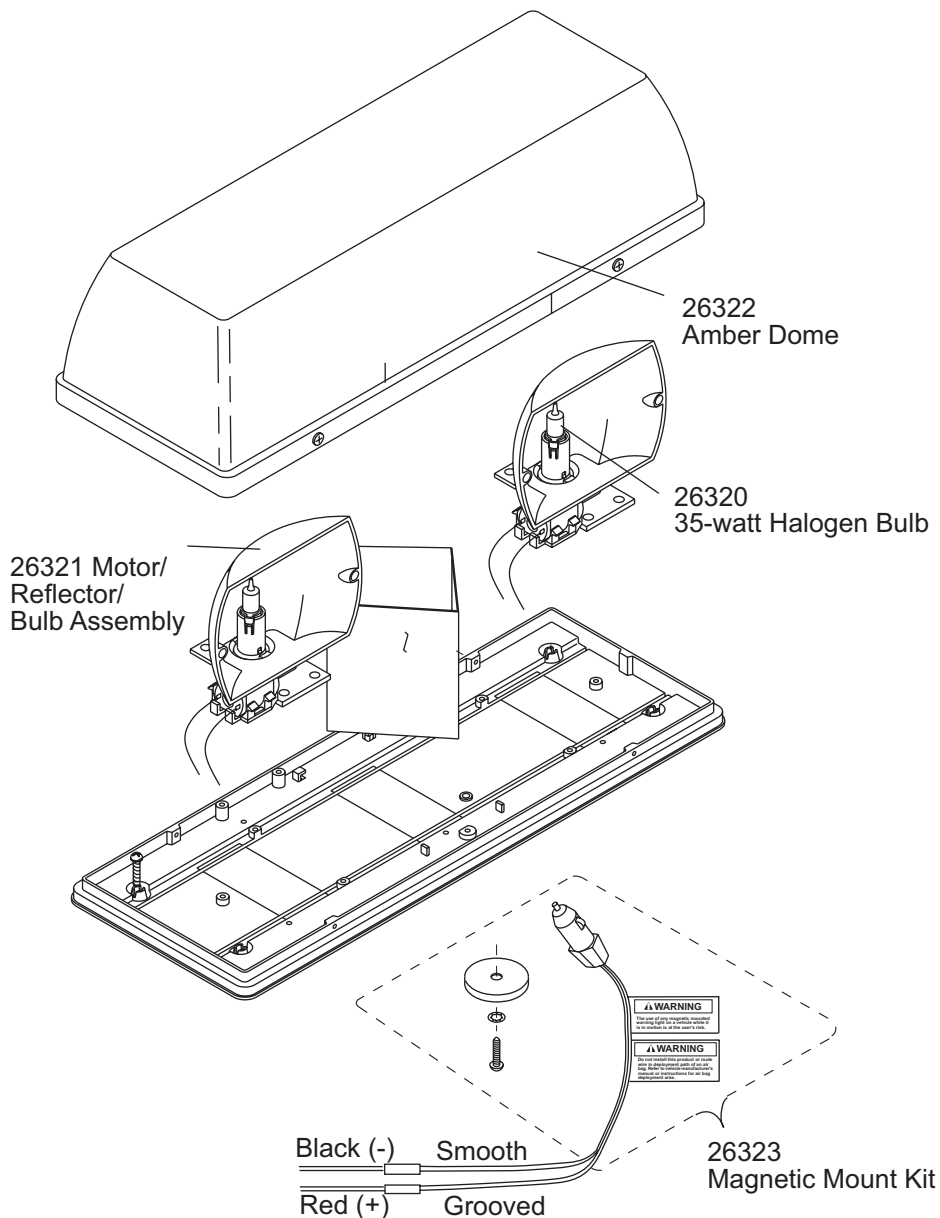

⚠ WARNING

The use of any magnetic mounted warning light on a vehicle while it is in motion is at the user's risk.

⚠ WARNING

Do not install this product or route wire in deployment path of an air bag. Refer to vehicle manufacturer's manual for air bag deployment area(s).

HALOGEN BULB REPLACEMENT

CAUTION

Do not handle the bulb with bare hands. Use gloves to prevent possible injury.

CAUTION

Replacing any halogen bulb requires the use of safety glasses to prevent injury.

1. Be sure to unplug the lamp from its power source before servicing lamp.
2. Remove the lens by unscrewing the four #6 x 3/8" phillips screws.
3. Insert a flat-blade screwdriver into the space between the lamp holder and the snap-in assembly. Gently rotate the screwdriver as shown. Repeat this action until bulb is loose.
4. Pull the bulb in an upward direction until it is free.
5. Verify the replacement bulb is the correct wattage (35 watts). Insert the alignment tab of the new bulb into the lamp holder and press downwards to lock the new bulb in place.
6. Replace lens using screw from Step 2.

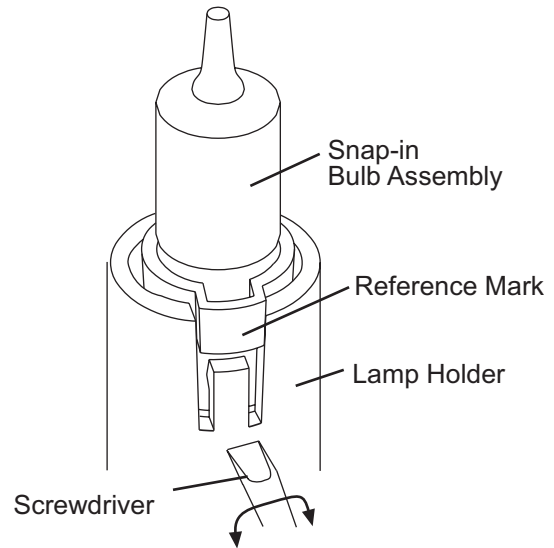

RECOMMENDATIONS

The outer surfaces of the strobe light may be cleaned with glass cleaner. Do not use abrasive or oil-based cleaners as they may dull the lens surface, resulting in reduced light output. Do not use a pressure washer!

Fisher Engineering reserves the right under its product improvement policy to change construction or design details and furnish equipment when so altered without reference to illustrations or specifications used herein. Fisher Engineering and the vehicle manufacturer may require and/or recommend optional equipment for snow removal. Fisher Engineering offers a limited warranty for all snowplows and accessories. See separately printed page for this important information. The following are registered (®) and unregistered (™) trademarks of Douglas Dynamics, L.L.C.: FISHER®

Printed in USA