

# INLET FITTING/FILTER KIT HYDRAULIC PUMP KIT

27748  
27746

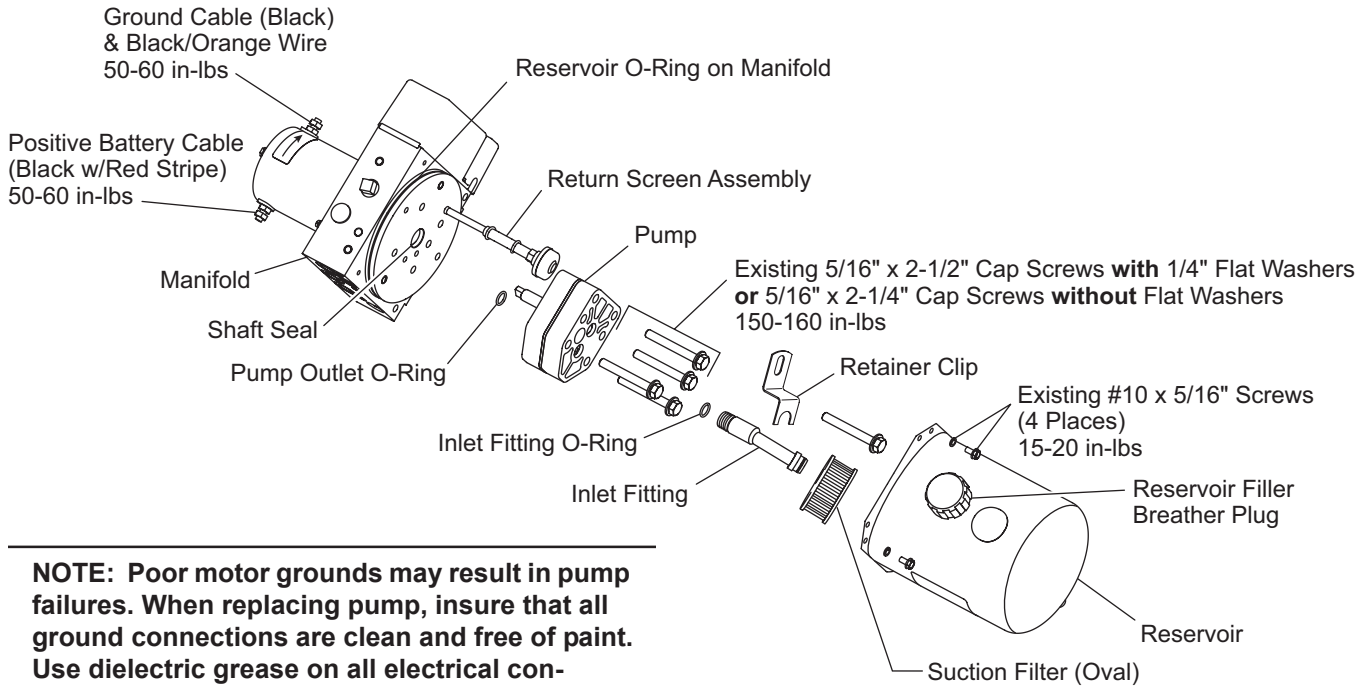

**NOTE: Poor motor grounds may result in pump failures. When replacing pump, insure that all ground connections are clean and free of paint. Use dielectric grease on all electrical connections to prevent corrosion. Fill receptacles and lightly coat ring terminals before assembly.**

1. Lower blade to floor.
2. Disconnect 8" hydraulic hose from reservoir fitting and drain fluid from reservoir. Remove the four screws and reservoir. Remove and discard reservoir o-ring. Remove the five cap screws and carefully remove pump from manifold. Clean pump mounting surface, o-ring groove, and reservoir.
3. Remove rubber band holding the pump sections together. Remove the protective plug from the counter-bored hole. Lubricate -013 o-ring (smaller of the two small o-rings) and place it into counter-bored hole. Carefully insert pump shaft into shaft seal in the manifold block. Fit pump alignment ring into shaft seal bore. If shaft side of pump is not flush to manifold surface, gently rotate pump body until pump shaft tang enters motor shaft slot. Align pump body with cap screw holes in manifold. Secure pump with five existing fasteners. Alternately tighten bolts to 150-160 in-lbs. torque.
4. Lubricate -014 o-ring (larger of the two small o-rings) and assemble it into the groove on the barbed end of the inlet fitting. Snap the suction filter on to the other end of the inlet fitting. Remove the protective plug from the inlet side of the pump body. Position the inlet fitting assembly as shown. Gently drive the barbed end of the inlet fitting squarely into the pump housing until the o-ring is not visible. Fitting can be rotated into final position after installation.
5. Remove indicated cap screw and install retainer clip over inlet fitting and under cap screw (and washer, if used) as shown. Tighten cap screw to 150-160 in-lbs.

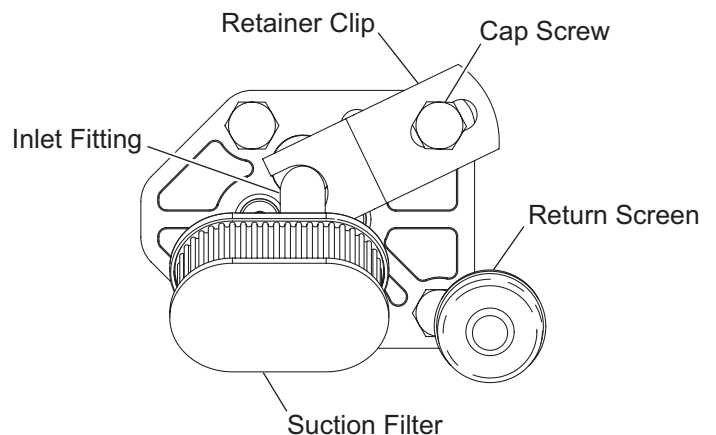
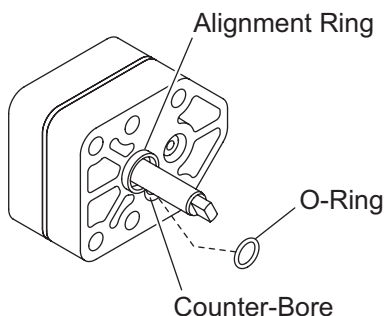

# INLET FITTING/FILTER KIT HYDRAULIC PUMP KIT

27748  
27746

- Lubricate and install new 2-250 reservoir o-ring. Lubricate inside edge of reservoir and carefully press reservoir evenly over o-ring onto manifold to avoid damaging o-ring. Secure with existing fasteners tightened to 15-20 in-lbs.
- Trim the reservoir filler breather plug as shown to prevent interference with the retainer clip.

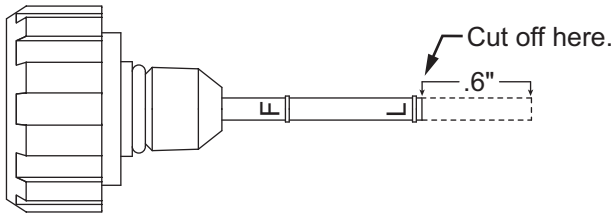

## To flush and refill the hydraulic system:

- Place the end of the 8" hose in a suitable container. Remove used oil from the lift ram by raising the blade with a floor jack until the ram is fully retracted. With blade raised, reattach hose to reservoir. Tighten hose fitting 1/8-1/4 turn past finger tight. Fill reservoir to full mark on filler breather plug with new hydraulic fluid. Refer to *Owner's Manual* for fluid recommendations. Lower blade to floor. The lift ram will take in fluid as it extends.
- Disconnect angle ram hoses at the manifold and place in a suitable container. Manually angle the blade fully to each side to remove fluid from the rams. Do not allow hose from extending ram to take in used fluid. Reattach hoses to manifold. Tighten hose fittings 1/8-1/4 turn past finger tight.
- Refill reservoir and angle the blade several times. Raise and lower the blade several times and refill reservoir to full mark.

27746 Hydraulic Pump Kit					
Item	Qty	Description	Item	Qty	Description
1	1	Hydraulic Pump	2	1	Inlet Fitting/Filter Kit (27748)
27748 Inlet Fitting/Filter Kit					
3	1	Suction Filter – Oval	6	1	O-Ring 2-250
4	1	Inlet Fitting	7	1	O-Ring -014
5	1	O-Ring -013	8	1	Retainer Clip

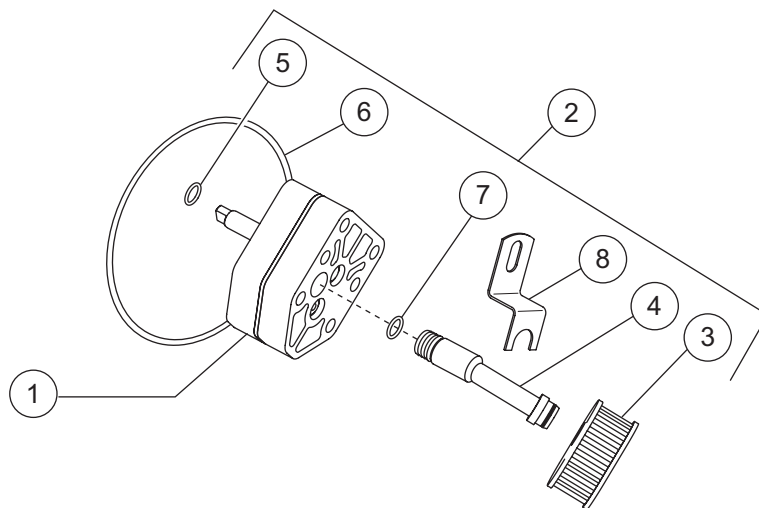

Copyright © 2004 Douglas Dynamics, L.L.C. All rights reserved. This material may not be reproduced or copied, in whole or in part, in any printed, mechanical, electronic, film or other distribution and storage media, without the written consent of the company. Authorization to photocopy items for internal or personal use by the company's outlets or snowplow owner is granted.

The company reserves the right under its product improvement policy to change construction or design details and furnish equipment when so altered without reference to illustrations or specifications used.

Printed in USA