



Fisher Engineering

P.O. Box 529 Rockland, Maine 04841 • www.fisherplows.com

December 21, 2006
Lit. No. 27817, Rev. 01

JOYSTICK SOLENOID CONTROL

Operation Instructions

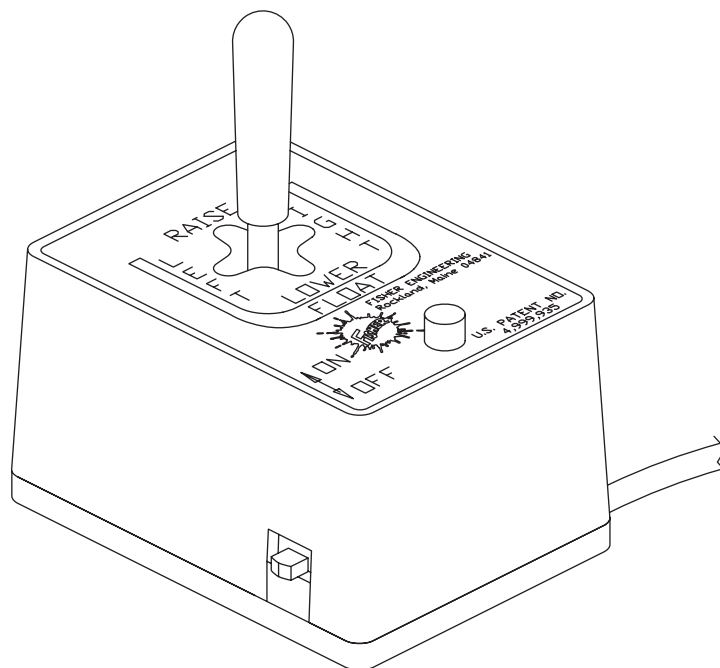

⚠ CAUTION

Read this document before installing the snowplow.

⚠ WARNING

To prevent accidental movement of the blade, always turn the ON/OFF switch to OFF whenever the snowplow is not in use. The control indicator light will turn off.

⚠ CAUTION

DO NOT hold control lever in RAISE, ANGLE LEFT or ANGLE RIGHT position after blade has reached desired position. To do so will use excess current and overheat components.

Turn the vehicle ignition switch to the ON or the ACCESSORY position. Move control ON/OFF switch to the ON position. The control indicator light (red) lights when the control ON/OFF switch and the ignition (key) are both turned ON. **The ON/OFF switch operates as emergency stop when required.**

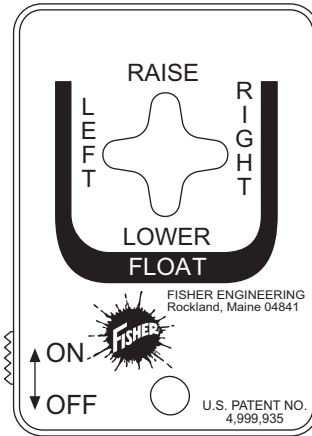

On/Off Switch (Emergency Stop)

Action	Description of Operation
ON/OFF	Slide the control power switch ON to activate the hydraulic system. Turn the control OFF to lock the blade in place. This prevents accidental movement of the blade.
RIGHT	Move the control lever right to angle the blade to the right.
LEFT	Move the control lever left to angle the blade to the left.
RAISE	Move the control lever up (forward) to raise the blade to the desired height.
LOWER/FLOAT	Move the control lever down (back) to lower the blade and activate the FLOAT mode.
To Cancel FLOAT	Cancel the FLOAT mode by momentarily placing the control in the RAISE position, turning the control off or turning the vehicle ignition off. Angling left or right does not cancel FLOAT.

Fisher Engineering reserves the right under its product improvement policy to change construction or design details and furnish equipment when so altered without reference to illustrations or specifications used. Fisher Engineering or the vehicle manufacturer may require or recommend optional equipment for snow removal. Do not exceed vehicle ratings with a snowplow. Fisher Engineering offers a limited warranty for all snowplows and accessories. See separately printed page for this important information. The following are registered (®) or unregistered (™) trademarks of Douglas Dynamics, L.L.C.: FISHER®.