



**Fisher Engineering**

P.O. Box 529 Rockland, Maine 04841 • www.fisherplows.com

 September 22, 2006  
 Lit. No. 29401, Rev. 01

# RUBBER DEFLECTOR

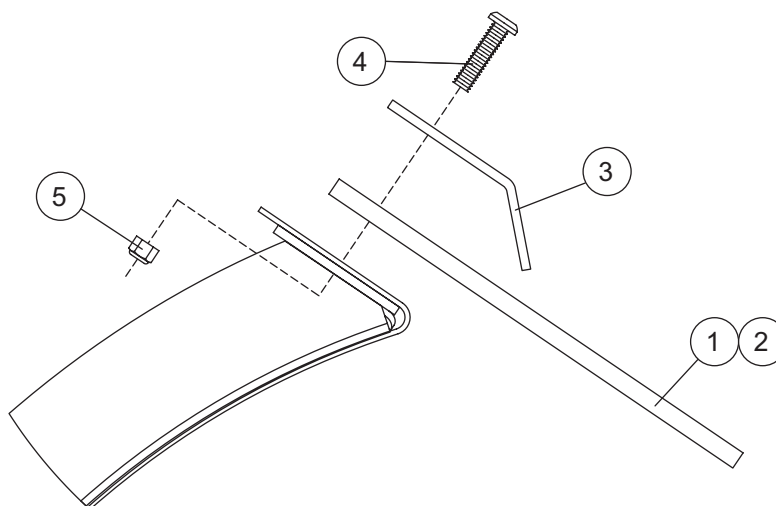
## XtremeV™ Snowplows

**PARTS LIST**

44710 Rubber Deflector Kit							
Item	Part	Qty	Description	Item	Part	Qty	Description
1	44651	1	Rubber Deflector FE – DS	3	44258	4	Deflector Hold Down
2	44653	1	Rubber Deflector – PS	ns	29404	1	Bolt Bag – XtremeV Rubber Deflector
29404 Bolt Bag – XtremeV Rubber Deflector							
4	98042	8	3/8-16 x 1.500 Button Cap Screw	5	95410	8	3/8-16 Brass, Nylon-Insert Locknut
ns = not shown				G = grade			

**⚠ WARNING**

Do not exceed GVWR or GAWR, including blade and ballast. The rating label is found on the driver-side vehicle door cornerpost.

**⚠ CAUTION**

Use standard methods and practices when attaching snowplow and installing accessories including proper personal protective safety equipment.

**⚠ CAUTION**

Read this document before installing the rubber deflector.

**⚠ CAUTION**

See your FISHER® outlet/Web site for specific vehicle application recommendations before installation. Rubber deflector weight information may be found in the Kit Selection Guide.

**INSTALLATION INSTRUCTIONS**

1. Starting from the outside edge of the driver-side blade half, remove the first three 3/8" x 1" button head cap screws that attach the moldboard to the blade frame.

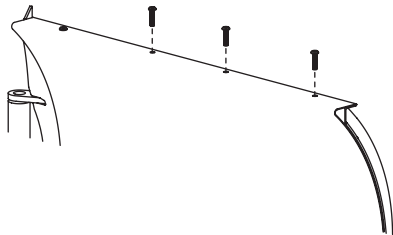

2. Place the rubber deflector with the logo on it on top of the moldboard and align the first hole in the deflector with the outermost hole in the moldboard. The deflector will extend beyond the end of the wing on 7-1/2' and 8-1/2' models.

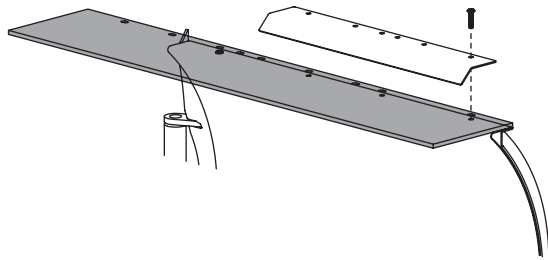

3. Place one of the deflector hold downs on top of the rubber deflector and wing, aligning the first hole in the hold down with the outermost hole in the moldboard.
4. Install one 3/8" x 1-1/2" button head cap screw through the outermost hole in the hold down, deflector and moldboard. Attach a 3/8" locknut to the cap screw and hand tighten.

5. Remove the remaining 3/8" x 1" moldboard fastener. Place a second deflector hold down on top of the rubber deflector and wing, aligning the last hole in the hold down with the innermost hole in the moldboard. The hold downs will overlap each other.

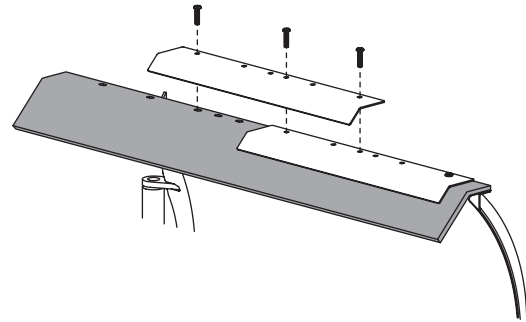

6. Install 3/8" x 1-1/2" button head cap screws through the three remaining holes in the hold down, deflector and moldboard. Attach a 3/8" locknut to each cap screw and hand tighten.
7. Make sure that the hold downs are tight against the deflector, then fully tighten all four cap screws.
8. **7-1/2' and 8-1/2' XtremeV™ Snowplows:** Trim the rubber deflector as shown.

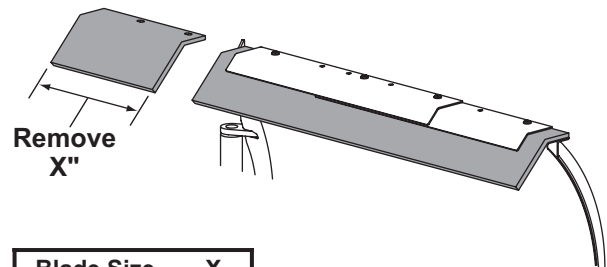

Blade Size	X
7-1/2'	12"
8-1/2'	6"
9-1/2'	None

7-1/2' blade wing shown

9. Repeat Steps 1–8 on passenger side.

Copyright © 2006 Douglas Dynamics, L.L.C. All rights reserved. This material may not be reproduced or copied, in whole or in part, in any printed, mechanical, electronic, film or other distribution and storage media, without the written consent of Fisher Engineering. Authorization to photocopy items for internal or personal use by Fisher Engineering outlets or snowplow owner is granted.

Fisher Engineering reserves the right under its product improvement policy to change construction or design details and furnish equipment when so altered without reference to illustrations or specifications used. Fisher Engineering or the vehicle manufacturer may require or recommend optional equipment for snow removal. Do not exceed vehicle ratings with a snowplow. Fisher Engineering offers a limited warranty for all snowplows and accessories. See separately printed page for this important information. The following are registered (®) or unregistered (™) trademarks of Douglas Dynamics, L.L.C.: FISHER®, XtremeV™.