

77102 MOUNT KIT

Ford Super Duty F-250/350/450/550

2017-__

Installation Instructions

▲ CAUTION

Read this document before installing the snowplow.

▲ CAUTION

See your sales outlet/website for specific vehicle application recommendations before installation. The online selection system has specific vehicle and snowplow requirements.

SAFETY DEFINITIONS

⚠ WARNING

Indicates a potentially hazardous situation that, if not avoided, could result in death or serious personal injury.

⚠ CAUTION

Indicates a potentially hazardous situation that, if not avoided, may result in minor or moderate injury. It may also be used to alert against unsafe practices.

NOTE: Indicates a situation or action that can lead to damage to your snowplow and vehicle or other property. Other useful information can also be described.

WARNING/CAUTION AND INSTRUCTION LABELS

Become familiar with and inform users about the warning labels on the back of the blade and the instruction label on the headgear.

NOTE: If labels are missing or cannot be read, see your sales outlet.

Warning/Caution Label

⚠ WARNING

Blade could drop unexpectedly, crushing or trapping limbs. Lower blade when vehicle is parked.

Overloading could negatively affect vehicle handling. To avoid serious injury or death, do not exceed GVWR or GAWR including blade and ballast.

⚠ CAUTION

Read Owner's Manual before operating or servicing snowplow.

Transport speed should not exceed 45 mph (72 km/h). Further reduce speed under adverse travel conditions.

Plowing speed should not exceed 10 mph (16 km/h).

See your sales outlet/website for specific vehicle application recommendations.

www.

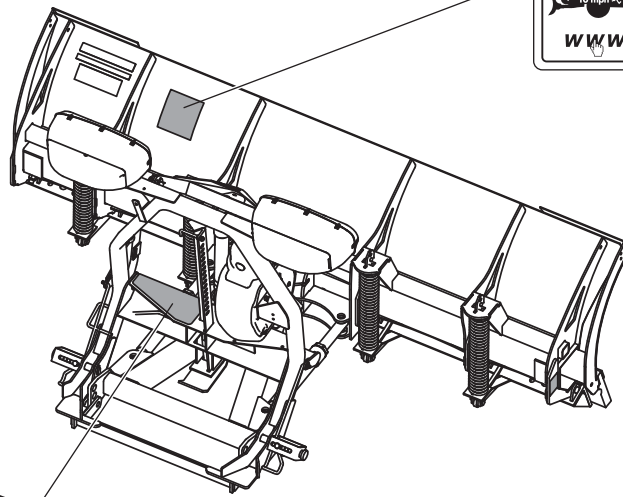

Instruction Label

1. Push **Pin Release Handle** down to pull out **Connecting Pins**.
2. Drive vehicle slowly to engage **Pushplates** into **Attachment Arms**.
3. Stand in front of blade. Fully raise **Pin Release Handle** to release **Connecting Pins**.
4. Push **Headgear** toward vehicle to allow **Connecting Pins** to fully engage **Pushplates**. If unable to push **Headgear** from in front of blade, stand in front of **Headgear** on driver side and push **Headlamp Bracket**.
5. Pull out **Jack Lock**. Push **Pin Release Handle** into **Stop**.
6. While holding **Jack Lock** out, use **Jack Handle** to raise **Jack** fully. Release **Jack Lock**.
7. Attach all electrical connectors.

ATTACH

US patents 6,944,978; 7,400,058; 7,430,821; 7,681,334; 7,737,576; 7,797,859; 9,200,418; 9,822,563; 10,793,056; CAN patents 2,354,257; 2,356,036; 2,632,102; 2,639,052; 2,843,997; and other patents pending.

Read Owner's Manual for complete instructions.

1. Place control in Lower/Float to put blade down.
2. Pull and hold **Jack Lock** out. **Jack** will drop to ground. Then pull **Pin Release Handle** away from **Stop** and **Jack Lock**. Release **Jack Lock**. Verify that **Jack** is locked by trying to lift **Jack**.
3. Stand in front of blade. While pushing **Headgear** toward vehicle with left hand, push **Pin Release Handle** down to disengage **Connecting Pins**. Make sure **Connecting Pins** are fully retracted. If unable to push **Headgear** from in front of blade, stand in front of **Headgear** on driver side and push **Headlamp Bracket**.
4. Detach all electrical connectors.

DETACH

SAFETY PRECAUTIONS

Improper installation and operation could cause personal injury and/or equipment and property damage. Read and understand labels and the Owner's Manual before installing, operating, or making adjustments.

⚠ WARNING

Lower the blade when vehicle is parked. Temperature changes could change hydraulic pressure, causing the blade to drop unexpectedly or damaging hydraulic components. Failure to do this could result in serious personal injury.

⚠ WARNING

The driver shall keep bystanders clear of the blade when it is being raised, lowered, or angled. Do not stand between the vehicle and the blade or within 8 feet of a moving blade. A moving or falling blade could cause personal injury.

⚠ WARNING

Keep hands and feet clear of the blade and A-frame when mounting or removing the snowplow. Moving or falling assemblies could cause personal injury.

⚠ WARNING

Do not exceed GVWR or GAWR including the blade and ballast. The rating label is found on the driver-side vehicle door cornerpost.

⚠ WARNING

To prevent accidental movement of the blade, always turn the control OFF whenever the snowplow is not in use. The power indicator light will turn OFF.

⚠ WARNING

Remove blade assembly before placing vehicle on hoist.

⚠ CAUTION

Refer to the online selection system for minimum vehicle recommendations and ballast requirements.

PERSONAL SAFETY

- Remove ignition key and put the vehicle in PARK or in gear to prevent others from starting the vehicle during installation or service.
- Wear only snug-fitting clothing while working on your vehicle or snowplow.
- Do not wear jewelry or a necktie, and secure long hair.
- Wear safety goggles to protect your eyes from battery acid, gasoline, dirt, and dust.
- Avoid touching hot surfaces such as the engine, radiator, hoses, and exhaust pipes.
- Always have a fire extinguisher rated BC handy, for flammable liquids and electrical fires.

FIRE AND EXPLOSION

⚠ WARNING

Gasoline is highly flammable and gasoline vapor is explosive. Never smoke while working on vehicle. Keep all open flames away from gasoline tank and lines. Wipe up any spilled gasoline immediately.

Be careful when using gasoline. Do not use gasoline to clean parts. Store only in approved containers away from sources of heat or flame.

CELL PHONES

A driver's first responsibility is the safe operation of the vehicle. The most important thing you can do to prevent a crash is to avoid distractions and pay attention to the road. Wait until it is safe to operate mobile communication equipment such as cell phones, text messaging devices, pagers, or two-way radios.

VENTILATION

⚠ WARNING

Vehicle exhaust contains lethal fumes. Breathing these fumes, even in low concentrations, can cause death. Never operate a vehicle in an enclosed area without venting exhaust to the outside.

NOISE

Airborne noise emission during use is below 70 dB(A) for the snowplow operator.









VIBRATION

Operating snowplow vibration does not exceed 2.5 m/s² to the hand-arm or 0.5 m/s² to the whole body.

TORQUE CHART

⚠ CAUTION

Read instructions before assembling. Fasteners should be finger tight until instructed to tighten according to the torque chart. Use standard methods and practices when attaching snowplow, including proper personal protective safety equipment.

Recommended Fastener Torque Chart					
Inch Fasteners Grade 5 and Grade 8					
Size	Torque (ft-lb)		Size	Torque (ft-lb)	
	 Grade 5	 Grade 8		 Grade 5	 Grade 8
1/4-20	8.4	11.9	9/16-12	109	154
1/4-28	9.7	13.7	9/16-18	121	171
5/16-18	17.4	24.6	5/8-11	150	212
5/16-24	19.2	27.3	5/8-18	170	240
3/8-16	30.8	43.6	3/4-10	269	376
3/8-24	35.0	49.4	3/4-16	297	420
7/16-14	49.4	69.8	7/8-9	429	606
7/16-20	55.2	77.9	7/8-14	474	669
1/2-13	75.3	106.4	1-8	644	909
1/2-20	85.0	120.0	1-12	704	995
Metric Fasteners Class 8.8 and 10.9					
Size	Torque (ft-lb)		Size	Torque (ft-lb)	
	 Class 8.8	 Class 10.9		 Class 8.8	 Class 10.9
M6 x 1.00	7.7	11.1	M20 x 2.50	325	450
M8 x 1.25	19.5	26.9	M22 x 2.50	428	613
M10 x 1.50	38.5	53.3	M24 x 3.00	562	778
M12 x 1.75	67	93	M27 x 3.00	796	1139
M14 x 2.00	107	148	M30 x 3.50	1117	1545
M16 x 2.00	167	231	M33 x 3.50	1468	2101
M18 x 2.50	222	318	M36 x 4.00	1952	2701
These torque values apply to fasteners except those noted in the instructions.					

INSTALLATION INSTRUCTIONS

NOTE: For easier assembly and installation, vehicle and all snowplow components should be on a smooth, level, hard surface, such as concrete.

1. Remove the air dam and bumper. Retain the fasteners for later installation.
2. Remove compatibility structures, if vehicle is so equipped. Retain them for reinstallation if the snowplow mount is removed from the vehicle.

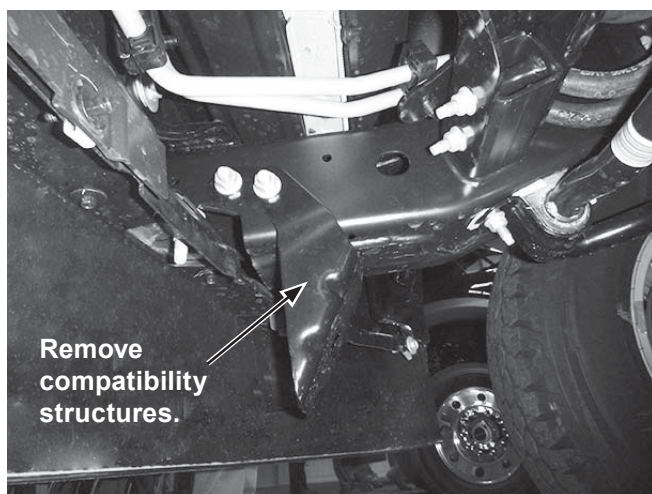

3. Remove the metal stabilizer bar brackets and retain for reinstallation later in this procedure.

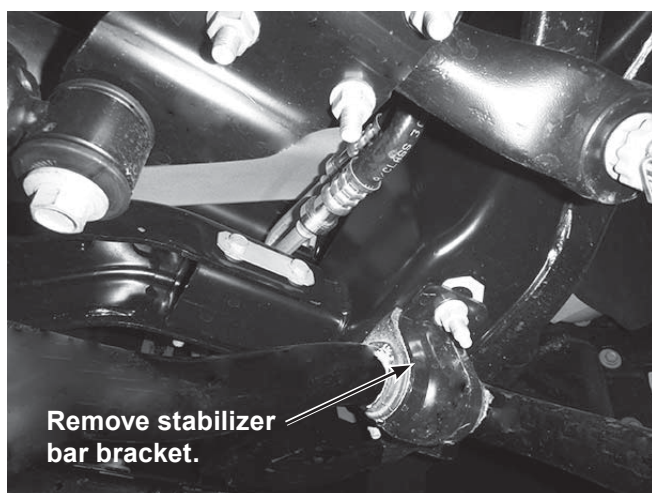

4. On the passenger's side, remove the nuts from the cross-beam bolt assembly.

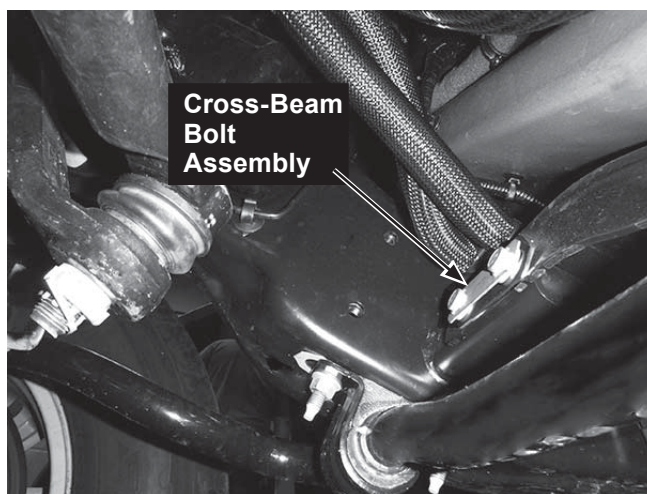

5. Position the rear bracket as shown, ensuring that the stabilizer bar bolts protrude through the rear bracket. Secure with the cross-beam bolt assembly nuts. On trucks with hose assemblies in close proximity to the cross-beam bolt assembly, the nuts should be installed on the front side of the cross beam, which may require removing the cross beam bolt assembly and inserting it from the back of the cross bar.

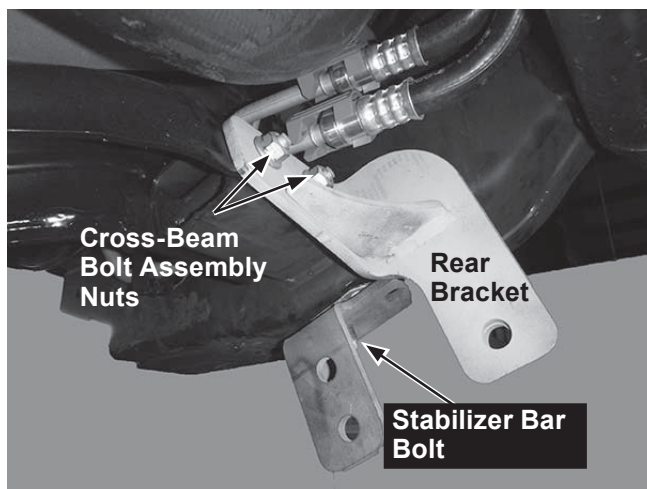

6. Repeat Steps 4 and 5 on the driver's side.

7. Position the stabilizer bar and stabilizer bar brackets as shown. Secure with the stabilizer bar nuts that were removed in Step 3.

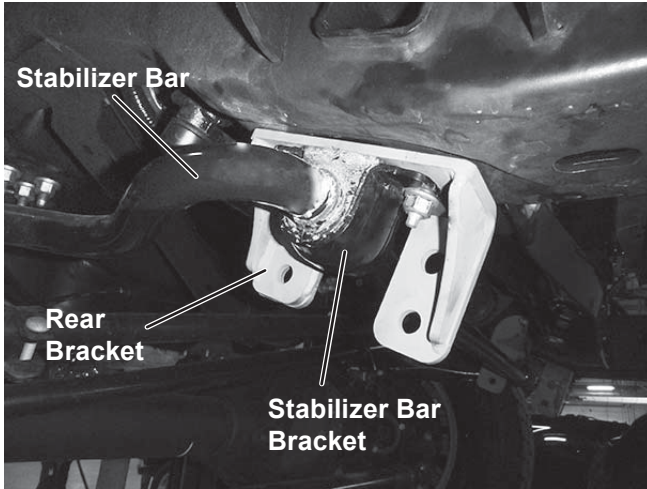

8. Position the passenger-side mount as shown. Insert two 1/2" x 2" cap screws through the mount holes against the inner frame surface. Secure each cap screw with a 1/2" locknut and 1/2" washer on the inside of the frame.

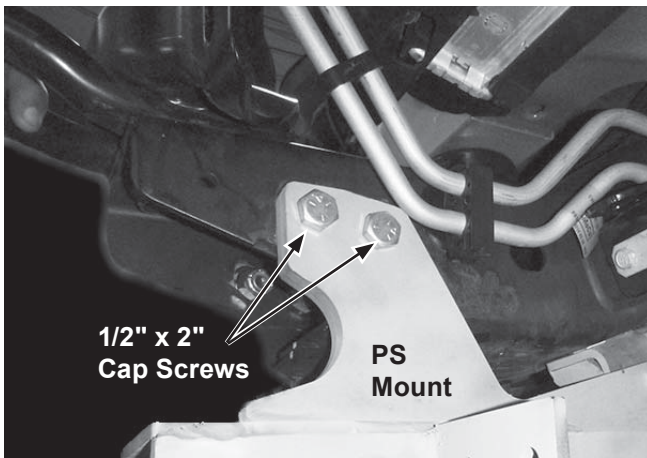

9. Insert three 1/2" x 1-1/2" cap screws through the mount holes against the outer frame surface. Secure each cap screw with a 1/2" washer and 1/2" locknut on the inside of the frame.

10. Attach the mount to the rear brackets using three 1/2" x 2" cap screws and 1/2" locknuts, using a 1/2" washer for the upper forward hole, as shown.

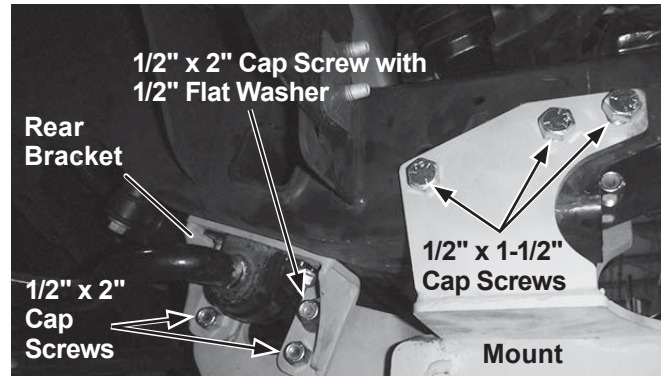

11. Repeat on the driver's side.

12. Position the cross bar as shown and secure with four 1/2" x 1-1/2" cap screws and 1/2" locknuts.

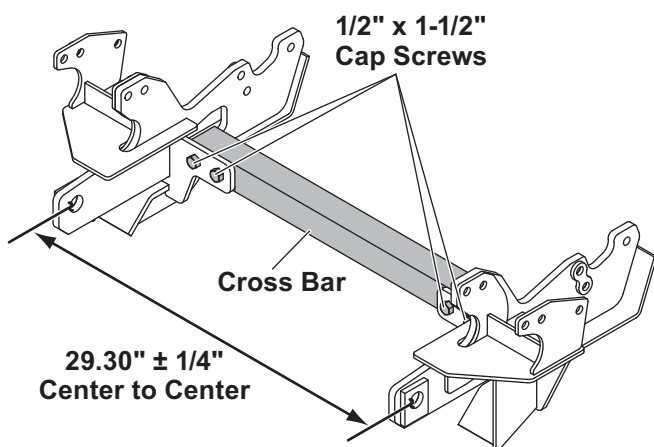

13. Check for a connecting arm distance of $29.30'' \pm 1/4''$. Adjust if needed and tighten the cross bar fasteners to set the specified separation distance.
14. Tighten all fasteners according to the torque chart provided.

15. Position the bumper in place. Notch the lower plastic section of the bumper to allow clearance for the mounts. Reattach the bumper using the original fasteners.

NOTE: Installation of the headlamp harnesses may require removal of the grille, which is easier if the bumper is off the vehicle. Do not reattach the bumper until the headlamp harness installation is complete.

16. Check clearances between the installed snowplow mount and any vehicle wires, hoses, and brake or cooling lines. Reposition and secure any interfering truck components to ensure at least 3/16" clearance, taking into account any possible movement of the truck components during normal operation.

NOTE: After five to ten hours of snowplow usage, retorque all mount assembly fasteners.

The company reserves the right under its product improvement policy to change construction or design details and furnish equipment when so altered without reference to illustrations or specifications used. This equipment manufacturer or the vehicle manufacturer may require or recommend optional equipment for snow removal. Do not exceed vehicle ratings with a snowplow. The company offers a limited warranty for all snowplows and accessories. See separately printed page for this important information.

Printed in U.S.A.
