



Minute Mount[®]

SYSTEM

MOUNT KIT

Ford Super Duty 250 4X4 & 350 4X4
Ford Super Duty 450 & 550

1999
1999

Parts List

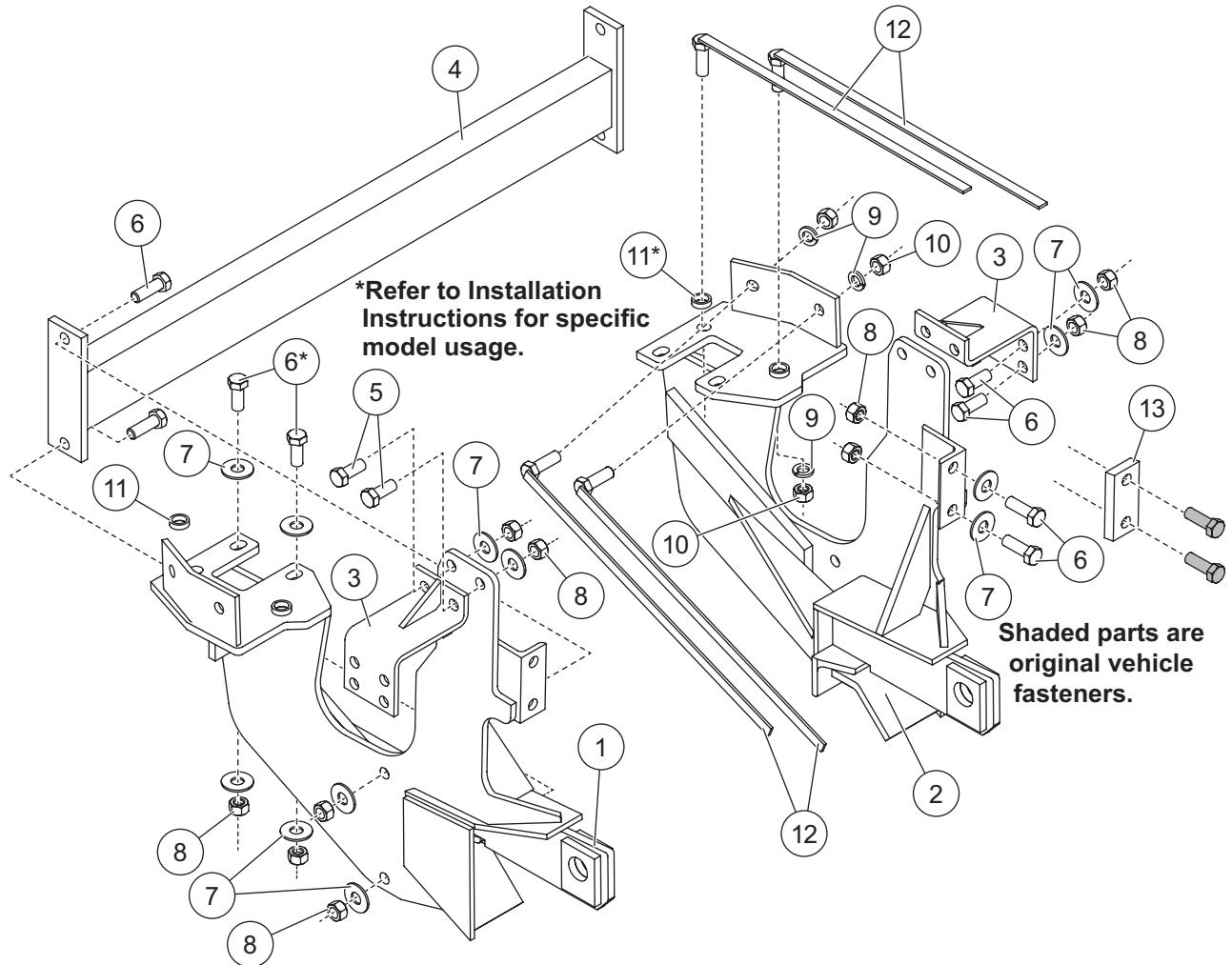

7159 Mount Kit							
Item	Part	Qty	Description	Item	Part	Qty	Description
1	22246	1	Pushplate, PS	4	22211	1	Spreader – Channel
2	22247	1	Pushplate, DS	ns	22302	1	Handled Cap Screw Bag
3	22289	2	Bracket	ns	22210	1	Bolt Bag
22210 Bolt Bag							
5		4	1/2-13 x 1-1/4 Hex Cap Screw G5	9		8	1/2 Lock Washer
6		16	1/2-13 x 1-1/2 Hex Cap Screw G5	10		8	1/2-13 Hex Nut
7		20	1/2 Plain Washer G8	11	22205	2	Bushing
8		20	1/2-13 Hex Locknut	ns		2	Cable Tie
22302 Handled Cap Screw Bag							
12	22314	8	1/2-13 x 1-1/2 Handled Hex Cap Screw G5, 18"	13	22323	2	1/2 Shim
ns = not shown				G = Grade			

INSTALLATION INSTRUCTIONS

⚠ CAUTION
 Read this document before installing the snowplow.

⚠ CAUTION
 See your FISHER® outlet/website for specific vehicle application recommendations before installation. The eMatch tool has specific vehicle and snowplow requirements.

SAFETY DEFINITIONS

⚠ WARNING
 Indicates a potentially hazardous situation that, if not avoided, could result in death or serious personal injury.

⚠ CAUTION
 Indicates a potentially hazardous situation that, if not avoided, may result in minor or moderate injury. It may also be used to alert against unsafe practices.

NOTE: Indicates a situation or action that can lead to damage to your snowplow and vehicle or other property. Other useful information can also be described.

SAFETY PRECAUTIONS

Improper installation and operation could cause personal injury and/or equipment and property damage. Read and understand labels and the Owner's Manual before installing, operating, or making adjustments.

⚠ WARNING
 Lower the blade when vehicle is parked. Temperature changes could change hydraulic pressure, causing the blade to drop unexpectedly or damaging hydraulic components. Failure to do this could result in serious personal injury.

⚠ WARNING
 The driver shall keep bystanders clear of the blade when it is being raised, lowered, or angled. Do not stand between vehicle and blade or within 8 feet of a moving blade. A moving or falling blade could cause personal injury.

⚠ WARNING
 Keep hands and feet clear of the blade and A-frame when mounting or removing the snowplow. Moving or falling assemblies could cause personal injury.

⚠ WARNING
 Do not exceed GVWR or GAWR including the blade and ballast. The rating label is found on the driver-side vehicle door cornerpost.

⚠ WARNING

To prevent accidental movement of the blade, always turn the control OFF whenever the snowplow is not in use. The power indicator light will turn OFF.

⚠ WARNING

Remove blade assembly before placing vehicle on hoist.

⚠ CAUTION

Refer to the eMatch tool for minimum vehicle recommendations and ballast requirements.

PERSONAL SAFETY

- Remove ignition key and put the vehicle in PARK or in gear to prevent others from starting the vehicle during installation or service.
- Wear only snug-fitting clothing while working on your vehicle or snowplow.
- Do not wear jewelry or a necktie, and secure long hair.
- Wear safety goggles to protect your eyes from battery acid, gasoline, dirt, and dust.
- Avoid touching hot surfaces such as the engine, radiator, hoses, and exhaust pipes.
- Always have a fire extinguisher rated BC handy, for flammable liquids and electrical fires.

FIRE AND EXPLOSION**⚠ WARNING**

Gasoline is highly flammable and gasoline vapor is explosive. Never smoke while working on vehicle. Keep all open flames away from gasoline tank and lines. Wipe up any spilled gasoline immediately.

Be careful when using gasoline. Do not use gasoline to clean parts. Store only in approved containers away from sources of heat or flame.

CELL PHONES

A driver's first responsibility is the safe operation of the vehicle. The most important thing you can do to prevent a crash is to avoid distractions and pay attention to the road. Wait until it is safe to operate mobile communication equipment such as cell phones, text messaging devices, pagers, or two-way radios.

VENTILATION**⚠ WARNING**

Vehicle exhaust contains lethal fumes. Breathing these fumes, even in low concentrations, can cause death. Never operate a vehicle in an enclosed area without venting exhaust to the outside.

NOISE

Airborne noise emission during use is below 70 dB(A) for the snowplow operator.









VIBRATION

Operating snowplow vibration does not exceed 2.5 m/s² to the hand-arm or 0.5 m/s² to the whole body.

TORQUE CHART

⚠ CAUTION

Read instructions before assembling. Fasteners should be finger tight until instructed to tighten according to the torque chart. Use standard methods and practices when attaching snowplow, including proper personal protective safety equipment.

Recommended Fastener Torque Chart					
Inch Fasteners Grade 5 and Grade 8					
Size	Torque (ft-lb)		Size	Torque (ft-lb)	
	 Grade 5	 Grade 8		 Grade 5	 Grade 8
1/4-20	8.4	11.9	9/16-12	109	154
1/4-28	9.7	13.7	9/16-18	121	171
5/16-18	17.4	24.6	5/8-11	150	212
5/16-24	19.2	27.3	5/8-18	170	240
3/8-16	30.8	43.6	3/4-10	269	376
3/8-24	35.0	49.4	3/4-16	297	420
7/16-14	49.4	69.8	7/8-9	429	606
7/16-20	55.2	77.9	7/8-14	474	669
1/2-13	75.3	106.4	1-8	644	909
1/2-20	85.0	120.0	1-12	704	995
Metric Fasteners Class 8.8 and 10.9					
Size	Torque (ft-lb)		Size	Torque (ft-lb)	
	 Class 8.8	 Class 10.9		 Class 8.8	 Class 10.9
M6 x 1.00	7.7	11.1	M20 x 2.50	325	450
M8 x 1.25	19.5	26.9	M22 x 2.50	428	613
M10 x 1.50	38.5	53.3	M24 x 3.00	562	778
M12 x 1.75	67	93	M27 x 3.00	796	1139
M14 x 2.00	107	148	M30 x 3.50	1117	1545
M16 x 2.00	167	231	M33 x 3.50	1468	2101
M18 x 2.50	222	318	M36 x 4.00	1952	2701
These torque values apply to fasteners except those noted in the instructions.					

INSTALLATION INSTRUCTIONS

NOTE: For easier assembly and installation, vehicle and all snowplow components should be on a smooth, level, hard surface, such as concrete.

1. Remove the bumper by first detaching the rubber flap and any electrical cords attached to the bumper (Diesel). Remove the four bumper fasteners and slide bumper forward until it is clear of the tow hooks. Remove and discard the two thin plates hanging from the bumper mounts.
2. Starting with the driver-side pushplate, position the rear section in place by fitting the pushplate between the leaf springs and the frame. On some vehicles it will be necessary to jack up the frame slightly to gain more clearance between the frame and the springs. Check for and eliminate any interference with the Ford nut retainers on the bottom of the frame.

⚠ CAUTION

To avoid damaging A/C condensers, use care when installing pushplates on vehicles with air conditioning. Heads of cap screws should be on the inside, with nuts on the outside of 22289 bracket, to increase clearance with condenser.

3. Once the rear section is in place, rotate the front section of the pushplate into place and loosely secure by attaching a bracket (PN 22289) with two 1/2" x 1-1/4" cap screws, 1/2" flat washers, and 1/2" locknuts. The heads of the cap screws should be on the inside when the vehicle is equipped with an A/C condenser. Slide the pushplate rearward to accomplish this. Loosely attach the front of the pushplate to the bumper plate on the frame using 1/2" x 1-1/2" cap screws, 1/2" flat washers, and 1/2" locknuts.

4. **For F-250, F-350, and all other vehicles with swaybar bracket:** Loosely attach the rear of the pushplate to the swaybar bracket using 1/2" x 1-1/2" cap screws, one 1/2" flat washer on top of the swaybar bracket, and one on the bottom of the pushplate slotted hole, and 1/2" locknuts.

For F-450, F-550, and all vehicles without swaybar bracket: Proceed to step 5.

5. Repeat Step 2–4 on the passenger's side.

NOTE: It is not always necessary to jack the frame up for additional clearance between the leaf springs and frame on the passenger's side.

6. Loosely attach the spreader channel between both pushplates using 1/2" x 1-1/2" cap screws, 1/2" flat washers, and 1/2" locknuts.
7. With the pushplate fitted snugly into position, clamp the brackets (PN 22289) to the top surface of the frame. Make sure that the bracket is sitting flush with the top frame surface and that the shim welded to the bracket is flush with the smaller boxed frame section. Tighten the fasteners at the front of the pushplate where it meets the bumper plate. These fasteners should now be located toward the tops of the slotted holes in the bumper plate.
8. Attach the rear of the pushplate.

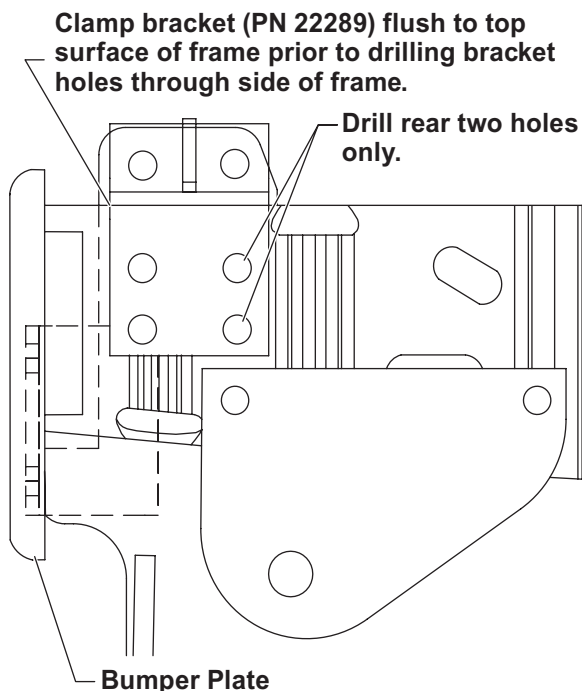

For F-250, F-350, and all other vehicles with swaybar bracket: With the rear of the pushplate fitted snugly to both the side and bottom of the frame, tighten the fasteners running through the swaybar bracket.

⚠ CAUTION

Use caution not to pinch, cut, or drill through any wires or hoses running along the frame rail.

Mark and drill two 17/32" holes through the side of the frame using the pushplate holes as guides. Fasten securely using two handled 1/2" x 1-1/2" cap screws, 1/2" lock washers, and 1/2" nuts.

NOTE: To assure a snug fit, loosen the swaybar bracket fasteners before tightening the handled cap screws, then re-tighten the bracket fasteners.

For F-450, F-550, and all vehicles without swaybar bracket: With the rear of each pushplate fitted snugly to both the side and the bottom of the frame, mark and drill two 9/16" holes through the bottom of the frame using the pushplate holes as guides. To facilitate drilling, remove the pushplates and drill smaller pilot holes to start. Holes will have to be drilled at an angle. Place a bushing between the pushplate and frame centered over the rear hole. Fasten securely using two handled 1/2" x 1-1/2" cap screws, 1/2" lock washers, and 1/2" nuts. Mark and drill two 17/32" holes through the side of the frame using the pushplate holes as guides. Fasten securely using two 1/2" x 1-1/2" handled cap screws, 1/2" lock washers, and 1/2" nuts.

⚠ CAUTION

Use caution not to pinch, cut, or drill through any wires or hoses running along the frame rail.

9. Drill the two rear holes in the brackets (PN 22289) and fasten using 1/2" x 1-1/2" cap screws, 1/2" flat washers, and 1/2" locknuts. Tighten all fasteners at this time according to the torque chart provided.

NOTE: Front holes in bracket (PN 22289) are not used at any time.

10. Use the cable ties to tie up cooling lines on the driver's side forward of the front-most radiator. It is important to provide sufficient clearance between all portions of the cooling lines and the driver-side pushplate.

NOTE: Use anti-chafing material in those situations where sufficient clearance cannot be obtained.

11. Place 1/2" shims in place to space the bumper forward of the frame. Reinstall bumper and reattach any rubber flaps or electrical cords removed during bumper removal.

NOTE: After five to ten hours of snowplow usage, retorque all pushplate assembly fasteners.

Copyright © 2023 Douglas Dynamics, LLC. All rights reserved. This material may not be reproduced or copied, in whole or in part, in any printed, mechanical, electronic, film, or other distribution and storage media, without the written consent of Fisher Engineering. Authorization to photocopy items for internal or personal use by Fisher Engineering outlets or snowplow owner is granted.

Fisher Engineering reserves the right under its product improvement policy to change construction or design details and furnish equipment when so altered without reference to illustrations or specifications used. Fisher Engineering or the vehicle manufacturer may require or recommend optional equipment for snow removal. Do not exceed vehicle ratings with a snowplow. Fisher Engineering offers a limited warranty for all snowplows and accessories. See separately printed page for this important information. The following are registered (®) trademarks of Douglas Dynamics, LLC: FISHER®, Minute Mount®.