

**8436, 8437-1, 8438, 8439,
8442, 8443, 27480-1, 27780,
27890, 28028, & 28400**

**HARNESS KIT
4-PORT ISOLATION MODULE
LIGHT SYSTEM**

w/2-PLUG SYSTEM HARNESSES

Installation Instructions

⚠ CAUTION

Read this document before installing the snowplow.

⚠ CAUTION

See your sales outlet/Web site for specific vehicle application recommendations before installation. The Kit Selection Guide/Selection List has specific vehicle and snowplow requirements.

SAFETY DEFINITIONS

⚠ WARNING

Indicates a potentially hazardous situation that, if not avoided, could result in death or serious personal injury.

⚠ CAUTION

Indicates a potentially hazardous situation that, if not avoided, may result in minor or moderate injury. It may also be used to alert against unsafe practices.

NOTE: Indicates a situation or action that can lead to damage to your snowplow and vehicle or other property. Other useful information can also be described.

FUSES

The snowplow electrical and hydraulic systems contain several automotive blade-style fuses. If a problem should occur and fuse replacement is necessary, the replacement fuse must be of the same type and amperage rating as the original. Installing a fuse with a higher rating can damage the system and could start a fire. Fuse replacement, including fuse ratings and locations, is located in the Maintenance section of the Owner's Manual.

BATTERY SAFETY



⚠ CAUTION

Batteries normally produce explosive gases which can cause personal injury. Therefore, do not allow flames, sparks or lit tobacco to come near the battery. When charging or working near a battery, always cover your face and protect your eyes, and also provide ventilation. Batteries contain sulfuric acid which burns skin, eyes and clothing. Disconnect the battery before removing or replacing any electrical components.

TORQUE CHART

⚠ CAUTION

Read instructions before assembling. Fasteners should be finger tight until instructed to tighten according to the torque chart. Use standard methods and practices when attaching snowplow, including proper personal protective safety equipment.

Recommended Fastener Torque Chart (Ft.-Lb.)			
Size	 SAE Grade 2	 SAE Grade 5	 SAE Grade 8
1/4-20	6	9	13
5/16-18	11	18	28
3/8-16	19	31	46
3/8-24	24	46	68
7/16-14	30	50	75
1/2-13	45	75	115
9/16-12	66	110	165
5/8-11	93	150	225
3/4-10	150	250	370
7/8-9	150	378	591
1-8	220	583	893

Metric Grade 8.8 (Ft.-Lb.)			
Size	Torque	Size	Torque
M 6	7	M 12	60
M 8	17	M 14	95
M 10	35	M 16	155

These torque values apply to fasteners except those noted in the instruction.

TYPICAL SYSTEM DIAGRAM

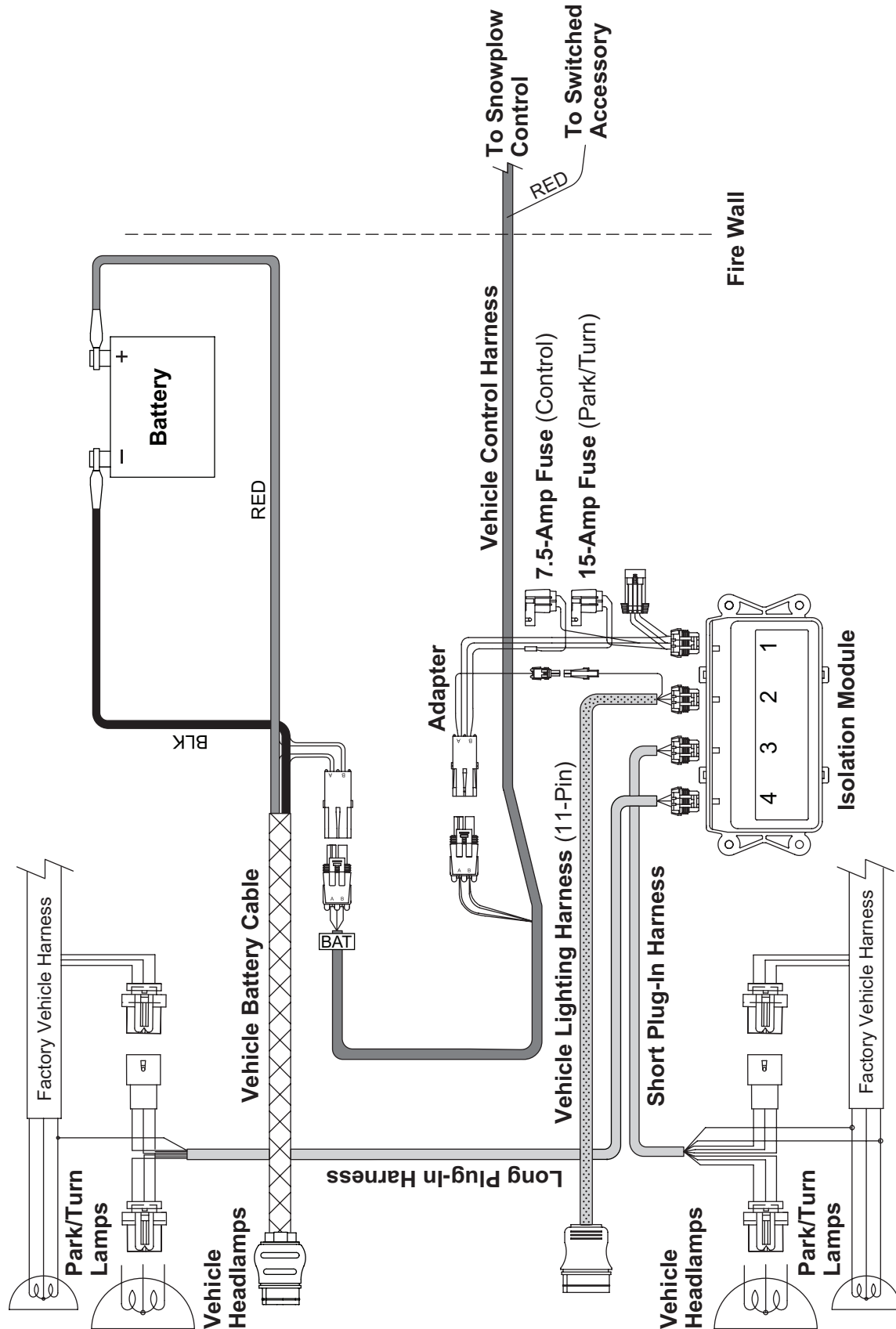

MOTOR RELAY AND VEHICLE BATTERY CABLE INSTALLATION

⚠ CAUTION

Batteries normally produce explosive gases which can cause personal injury. Therefore, do not allow flames, sparks or lit tobacco to come near the battery. When charging or working near a battery, always cover your face and protect your eyes, and also provide ventilation.

Batteries contain sulfuric acid which burns skin, eyes and clothing.

Disconnect the battery before removing or replacing any electrical components.

NOTE: When instructed, make all snowplow battery cable connections to the auxiliary battery, if vehicle is so equipped.

NOTE: For vehicles equipped with a tilt cab or tilt hood, a service loop will be necessary when making harness or cable transitions from the cab/hood to the frame. Check the cable installation for interference by raising and lowering the cab/hood a number of times. Add anti-chafing material (installer-supplied) as needed.

1. Turn off the vehicle ignition.
2. Disconnect both the NEGATIVE (–) and the POSITIVE (+) battery cables.
3. Route the supplied vehicle battery cable from the grille or bumper to the battery, avoiding any sharp edges and hot or moving parts. Cable tie only the end section closest to the grille. Lengthening the vehicle battery cable may be necessary on vehicles with batteries located under or behind

the cab. If lengthening cables is necessary, use an isolated stud junction block (purchased separately – PN 40284). Mount the block to a flat surface within reach of the vehicle battery cable, and connect both the vehicle battery cable and the supplied 50" or 90" battery cable to the junction block.

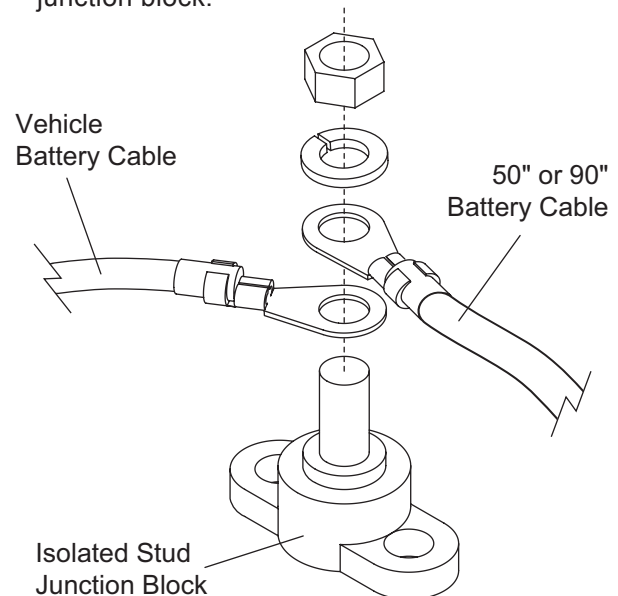

4. Route the red wire from the vehicle battery cable (or 50"/90" battery cable) to the POSITIVE (+) battery terminal. Do not connect at this time.

NOTE: Use dielectric grease on all electrical connections to prevent corrosion. Fill receptacles and lightly coat ring terminals and blades before assembly.

5. Route the black wire from the vehicle battery cable to the NEGATIVE (–) battery terminal. Do not connect at this time. On vehicles with the batteries located under or behind the cab, connect the black wire from the vehicle battery cable to the frame using an existing hole or ground bolt. Prior to attaching, clean away any paint or dirt to ensure a good ground connection. The 4-position connector from the vehicle battery cable will connect to the mating connector (labeled "BAT") on the end of the vehicle control harness.

PLUG COVER INSTALLATION

1. Stretch the rectangular opening of the plug cover strap over the end of the molded plug. Place the plug cover over the molded plug when snowplow is not in use.

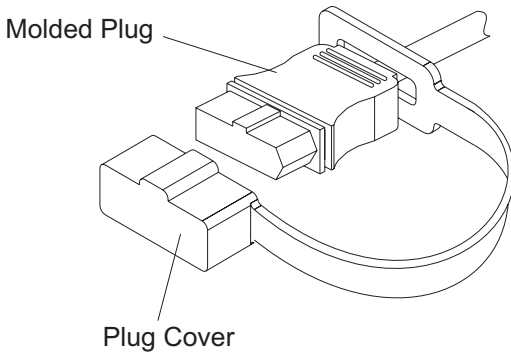

2. If grille plates were not provided, secure the vehicle battery cable so it is protected when not in use and is easily retrieved for connection to the snowplow.
3. If grille plates were provided or you choose to use them, pick the one most suitable for your installation. Slide the plug into the plate.

NOTE: When choosing a location for the grille plate, keep in mind the connection between the vehicle and the snowplow. Mounting the grille plate too close to the center of the vehicle may make it difficult to make your electrical connection to the snowplow.

ISOLATION MODULE MOUNTING

The design of the Isolation Module allows it to be mounted to a variety of surfaces within the engine compartment. The function of the Isolation Module will not be affected by its mounting orientation.

⚠ CAUTION

Before installing self-drilling screws or drilling mounting holes, check the selected mounting area for any wires, hoses, or other obstructions.

Locate a flat surface within the engine compartment of the vehicle for mounting the Isolation Module. For example, the fire wall, fender well or radiator shroud are possible mounting locations. If a flat surface cannot be located, cable tie the Isolation Module to existing brackets or harnessing. Reclosable fastener strips, cable ties, and self-drilling screws are supplied for mounting the Isolation Module. When using the reclosable fastener strips, the mounting surface must be free of dirt and grease. If using self-drilling screws, install the screws in opposite corners if possible.

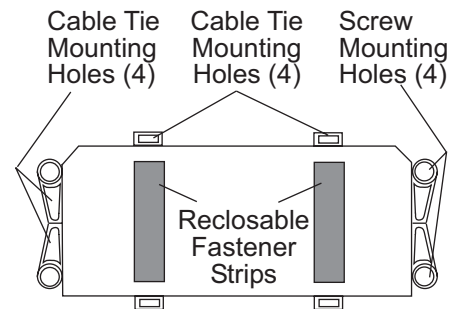

Isolation Module
Bottom View

VEHICLE LIGHTING AND VEHICLE CONTROL HARNESS INSTALLATION

NOTE: For vehicles equipped with a tilt cab or tilt hood, a service loop will be necessary when making harness or cable transitions from the cab/hood to the frame. Check the cable installation for interference by raising and lowering the cab/hood a number of times. Add anti-chafing material (installer-supplied) as needed.

1. Route the vehicle lighting harnesses around or through the radiator bulkhead to the Isolation Module.
2. Make the following connections:
 - Vehicle lighting harness to Port 2 on Isolation Module.*
 - 10-position connector from supplied adapter to Port 1 on Isolation Module.
 - 4-position connector from vehicle control harness to supplied adapter.
 - Single-wire connector (black/orange wire) from vehicle lighting harness to single-wire connector (black/orange wire) on supplied adapter.
 - **For the 8437-1 or 27780 Harness Kit:** Connect supplied dust cover to vehicle control harness 3-position plug near Isolation Module.
 - **For all other harness kits:** Connect configuration plug to vehicle control harness 3-position plug near Isolation Module. (Refer to plug configuration drawing for instructions.)

NOTE: If unsure of headlamp common, configure plug for a **NEGATIVE (-)** common. Complete the installation and check headlamp functions. Turn on the vehicle lights in the low beam mode. Both low beams should be on. If the left low beam does not illuminate, change plug configuration to **POSITIVE (+)** common and test headlamp functions.

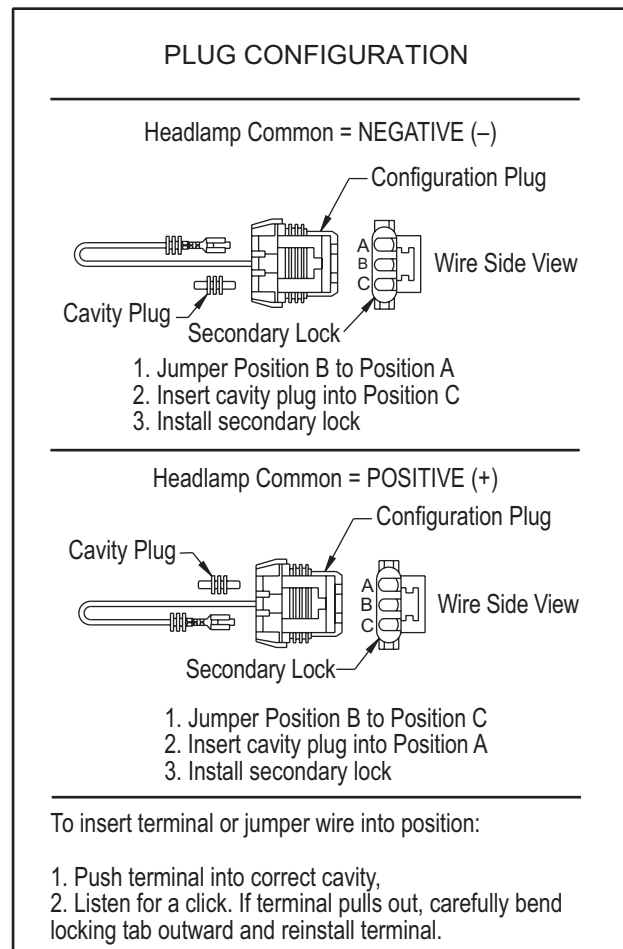

3. Route the end of the vehicle control harness with the white, 4-pin connector to the fire wall.
4. Connect the black 4-position connector (labeled "BAT") on the end of the vehicle control harness to the 4-position connector on the vehicle battery cable. Do not cable tie harness at this time.

⚠ CAUTION

Before installing self-drilling screws or drilling mounting holes, check the selected mounting area for any wires, hoses, or other obstructions.

5. On the driver side, locate an existing hole through the fire wall for the vehicle control harness. If access through the fire wall does not exist, drill a 5/8" hole through the fire wall of the vehicle in a convenient location away from sharp edges, and hot or moving parts.
6. Push the braided harness breakout with the cab control connector through the fire wall hole into the cab. Use a grommet, existing plug cover, or proper chafing material to protect the harness where it passes through the fire wall. Route the harness to the selected control mounting location. To mount the control, follow the instructions supplied with the control.
7. Locate an accessory wire controlled by the ignition switch. Acceptable accessory wires show +12V when the ignition switch is on, and 0V when it is off.
8. Route the red wire from the vehicle control harness to this location and trim away excess length.
9. Following the recommended splicing procedure, splice the red wire into the switched accessory wire using the supplied parallel splices and heatshrink tubing.

**PLUG-IN HARNESS INSTALLATION:
VEHICLES USING THE 27890 HARNESS
KIT**

1. Locate the passenger-side OEM vehicle headlamp connector located near the tilt-hood hinge below the headlamp housing.
2. Remove the small, light gray connector lock by carefully sliding it back away from the connector. Separate the connectors by pushing down on the locking tab and pulling them apart.
3. Connect the short plug-in harness female connector to the male OEM vehicle headlamp connector. Reinstall the small, light gray connector lock.
4. Connect the short plug-in harness male connector to the female OEM vehicle headlamp connector.
5. Repeat Steps 1–4 on the driver side of the vehicle using the long plug-in harness.
6. Route the plug-in harnesses to the 4-port Isolation Module by running the harnesses along the existing cables underneath the engine and radiator area. Connect **driver-side** plug-in harness to Port 3 on the Isolation Module. Connect **passenger-side** plug-in harness to Port 4 on the Isolation Module.
7. Cable tie the vehicle control harness, vehicle lighting harness and both plug-in harnesses away from any sharp, hot or moving parts. The vehicle control harness and vehicle lighting harness are designed to plug into one another for storage.

**PLUG-IN HARNESS INSTALLATION:
VEHICLES USING THE 8443 HARNESS
KIT**

1. Locate the passenger-side OEM vehicle headlamp connector located near the tilt-hood hinge below the headlamp housing.
2. Remove the small, light gray connector lock by depressing the tabs on both sides and pulling outward. Save the connector lock.
3. Disconnect the connector by lifting up on the locking tab and pulling it apart. Carefully unclip the vehicle headlamp harness and reroute it back to the frame, cable tying as necessary.
4. Connect the plug-in harness female connector to the male OEM vehicle headlamp connector. Reinstall the small, light gray connector lock. Route the plug-in harness back toward the frame using existing cable clips.
5. Connect the plug-in harness male connector to the female OEM vehicle headlamp connector.
6. Route the plug-in harness to the 4-port Isolation Module. Connect the plug-in harness to the module by matching harness connector 3 with Port 3 on the Isolation Module and harness connector 4 with Port 4 on the Isolation Module.
7. Cable tie the vehicle control harness, vehicle lighting harness and plug-in harness away from any sharp, hot or moving parts. The vehicle control harness and vehicle lighting harness are designed to plug into one another for storage.

**PLUG-IN HARNESS INSTALLATION:
ALL OTHER APPLICATIONS**

NOTE: For vehicles equipped with a tilt cab or tilt hood, a service loop will be necessary when making harness or cable transitions from the cab/hood to the frame. Check the cable installation for interference by raising and lowering the cab/hood a number of times. Add anti-chafing material (installer-supplied) as needed.

1. **For vehicles using the 8436 Harness Kit with the 26641 or 28860 Adapter Kit:** Refer to the illustration below, and configure both plug-in harnesses for HB-5.

For vehicles using the 28028 Harness Kit: The plug-in harnesses connect to the headlamp housings, not the headlamp bulbs.

Install wires in both connectors as shown.
Install supplied secondary connectory locks.

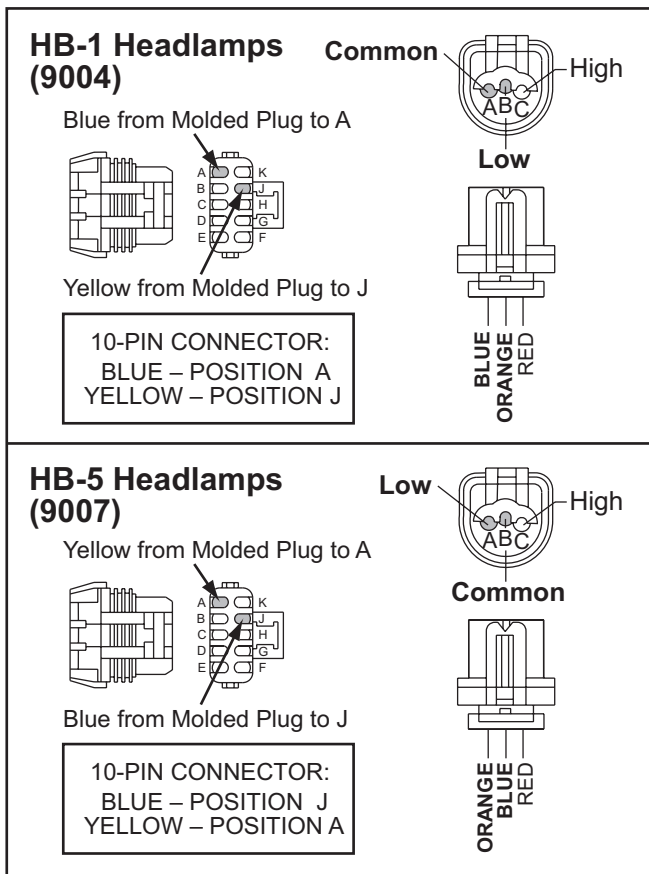

For all other vehicles using the 8436 Harness Kit: Refer to the previous illustration, and configure both plug-in harnesses according to the vehicle's headlamp type.

2. Remove the headlamp or headlamp housing connectors. Connect the plug-in harnesses to the mating connectors removed from the headlamps or headlamp housings.* Connect the plug-in harnesses to the mating connections at the headlamps or headlamp housings. Route harnesses to the Isolation Module. Connect **driver-side** plug-in harness to Port 3 on the Isolation Module. Connect **passenger-side** plug-in harness to Port 4 on the Isolation Module.

NOTE: Only the short plug-in harness connects to the vehicle parking light and DRL circuits.

For vehicles with dedicated DRL bulbs: Splice the pink wire from the short plug-in harness into the DRL POSITIVE (+) wire following the splicing procedure.

For vehicles with headlamp DRLs: The pink wire from the short plug-in harness, if present, is not needed. Cut and discard the pink wire.

3. If not already done during adapter installation, locate the turn signal wire on each side of the vehicle. Splice the purple wire from each plug-in harness into the signal wire on the corresponding side following the recommended splicing procedure.
4. If not already done during adapter installation, splice the brown wire from the short plug-in harness into the parking light wire following the splicing procedure.
5. Cable tie the vehicle control harness, vehicle lighting harness, and both plug-in harnesses away from any sharp, hot or moving parts. The vehicle control harness and vehicle lighting harness are designed to plug into one another for storage.

BATTERY CABLE CONNECTIONS

Top Post Batteries w/Lead Cable Ends

1. Attach the POSITIVE (+) OEM cable to the battery post. Attach the red battery cable to the bolt in the OEM terminal with the original fastener.
2. Attach the NEGATIVE (-) OEM cable to the battery post. Attach the black wire from the vehicle battery cable to the OEM terminal bolt with the original fastener.

Top Post Batteries w/Stamped Steel Battery Terminals

Top Post Batteries, Style One

These terminals are secured with a 6mm washer-head cap screw and nut.

1. If the cap screw is long enough for the added thickness of the cable terminal, washer, and nut, it will not need to be replaced, and Step 2 may be skipped.
2. Carefully lift retainer tabs (if present), and remove the short cap screw. Insert the supplied longer cap screw through a 3/16" washer and into the hole in the clamp. Carefully bend the retainer tabs back into place.

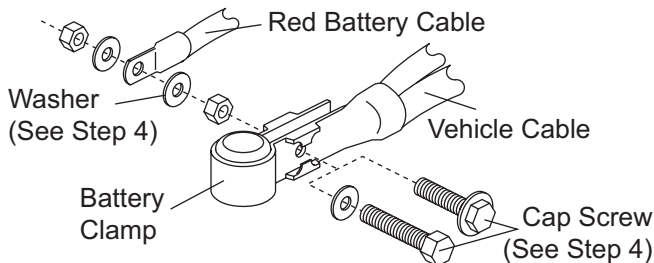

3. Attach POSITIVE (+) OEM battery clamp to battery post, and secure clamp.
4. Place the red battery cable over the end of the battery terminal screw. If added terminal has large contact area with the battery clamp, retain with a washer and nut. If the terminal contact area is small (i.e., terminal hole almost passes over a 6mm nut), add a washer to both sides of the cable, and secure with a nut.
5. Connect the black wire from the vehicle battery cable and the OEM NEGATIVE (-) cable to the NEGATIVE (-) battery terminal following the same procedure used in Steps 1-4.

Top Post Batteries, Style Two

These terminals are secured with a 6mm tapered nut and cam.

1. Make the connections to the POSITIVE (+) terminal as follows:
 - a. Remove cable assembly from battery post by loosening the nut. Trim plastic terminal cover as shown.

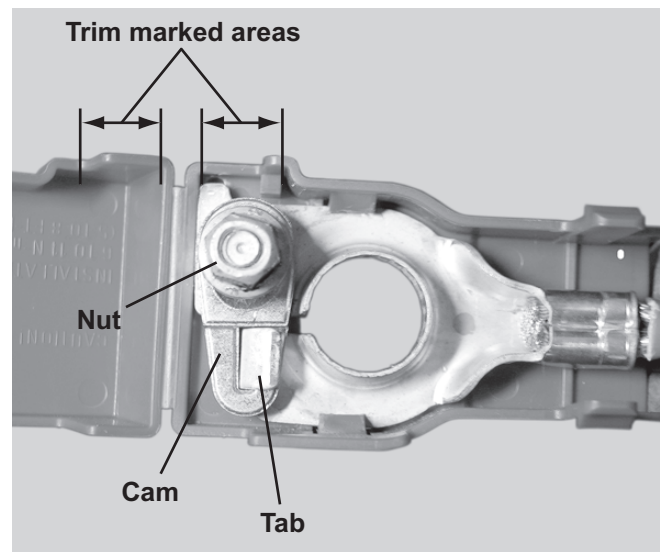

- b. Carefully bend tab securing the cam upward so the cam can be lifted off the stamped terminal after the nut has been removed.
- c. Place the red battery cable over the battery terminal screw.
- d. Slide the cam over the terminal screw and tab. Reinstall the nut.
- e. Place cable assembly on battery post, align red battery cable with the opening in the cover, and tighten nut. Close plastic terminal cover.

2. Make the connections to the NEGATIVE (-) terminal as follows:
 - a. Remove cable assembly from battery post by loosening the nut.
 - b. Carefully bend tab securing the cam upward so the cam can be lifted off the stamped terminal after the nut has been removed.
 - c. Place the black wire from the vehicle battery cable over the battery terminal screw.
 - d. Slide the cam over the terminal screw and tab. Reinstall the nut.
 - e. Place cable assembly on battery post, and tighten nut.

Top Post Batteries, Style Three

These terminals are similar to Style Two, but do not have a visible cam or tab.

1. Make the connections to the POSITIVE (+) terminal as follows:
 - a. Remove cable assembly from battery post by removing the nut. Trim plastic terminal cover as necessary to accommodate the red snowplow battery cable.
 - b. Place the red battery cable over the battery terminal screw and reinstall the nut.
 - c. Place cable assembly on battery post, align red battery cable with the opening in the cover, and tighten nut. Close plastic terminal cover.
2. Make the connections to the NEGATIVE (-) terminal as follows:
 - a. Remove cable assembly from battery post by removing the nut.
 - b. Place the black wire from the vehicle battery cable over the battery terminal screw and reinstall the nut.
 - c. Place cable assembly on battery post, and tighten nut.

Side Terminal Batteries

1. Use the furnished battery cable adapter to attach the red battery cable to the POSITIVE (+) terminal of the battery. Position the cable, and tighten the adapter to 124–178 in-lb.
2. Connect the OEM POSITIVE (+) cable to the adapter on the battery. Position the cable, and while holding the adapter, tighten the battery cable bolt to 124–178 in-lb.
3. Connect the black wire from the vehicle battery cable and the OEM NEGATIVE (-) cable to the NEGATIVE (-) battery terminal following the same procedure used in Steps 1 and 2.

RECOMMENDED SPLICING PROCEDURE

1. Locate wire to be spliced into.
2. Cut wire at least 1-1/2" from any other splice, connector, or terminal. If wires are covered by tubing or braid, remove enough of it to achieve the minimum clearance required.
3. Strip away 5/16" of the insulation from the ends of the wires to be spliced.
4. Slide two wires into one end of the supplied parallel splice.
5. Place a piece of heatshrink tubing (3/16" x 1-1/4" long) over the remaining wire to be spliced. Cut tubing into 1-1/4" lengths if required.
6. Insert wire into the open end of the splice and crimp using an appropriate crimp tool. One or two crimps may be necessary to ensure a good connection. No wire strands should be visible outside of the splice.
7. Preheat a soldering tool for at least one minute to help promote even solder flow.
8. Apply heat to the splice. Avoid heating too close to the insulation. Apply solder to the wires. Use just enough solder to produce an even flow through the splice. **Use rosin core solder ONLY. Do not use acid core solder.**

NOTE: Avoid using an excessive amount of solder as it can result in wicking. Wicking occurs when solder travels up the wire core. This may cause the wire to become stiff or brittle which could lead to a broken or open circuit.

9. Check circuits for continuity.
10. Cover the splice with heatshrink tubing. The tubing should extend beyond the splice on both sides.
11. Using a hot air source, starting in the center and working to either side, apply heat until the tubing recovers and glue can be seen around the edges. Allow the tubing to cool before handling.

NOTE: The splices supplied will accommodate 18-gauge wires as shown. For larger gauge wires, cut the wire, strip the ends 3/8" to 1/2", and twist together. Apply solder to the splice and cover with heatshrink tubing.

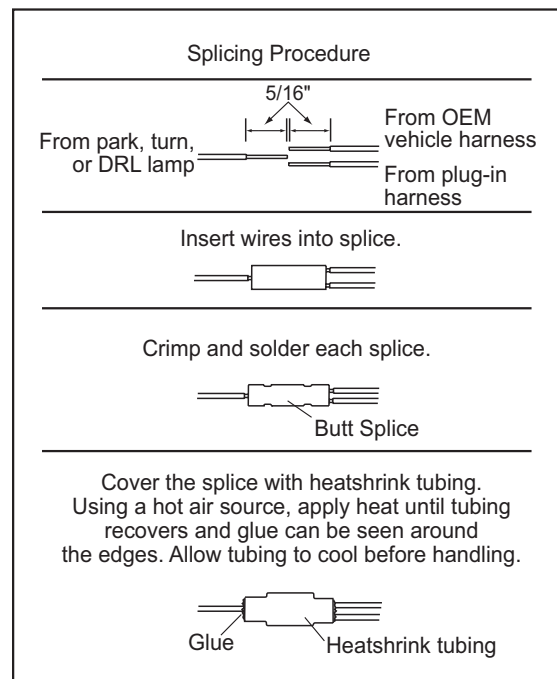

8436, 8437-1, 8438, 8439, 8442, 8443, 27480-1, 27780, 27890, 28028, 28400

8436, 8437-1, 8438, 8439, 8442, 8443, 27480-1, 27780, 27890, 28028, 28400

The company reserves the right under its product improvement policy to change construction or design details and furnish equipment when so altered without reference to illustrations or specifications used. This equipment manufacturer or the vehicle manufacturer may require or recommend optional equipment for snow removal. Do not exceed vehicle ratings with a snowplow. The company offers a limited warranty for all snowplows and accessories. See separately printed page for this important information.

Printed in U.S.A.
