

DOUBLE-ACTING RAM SEALS

INSTALLATION INSTRUCTIONS

1. Lubricate O-rings before assembly.
2. Assemble gland components as shown, then lubricate.

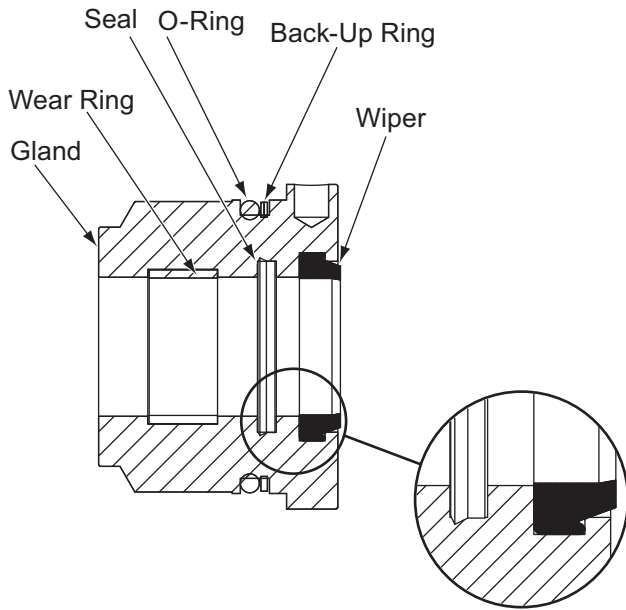

Seal Position

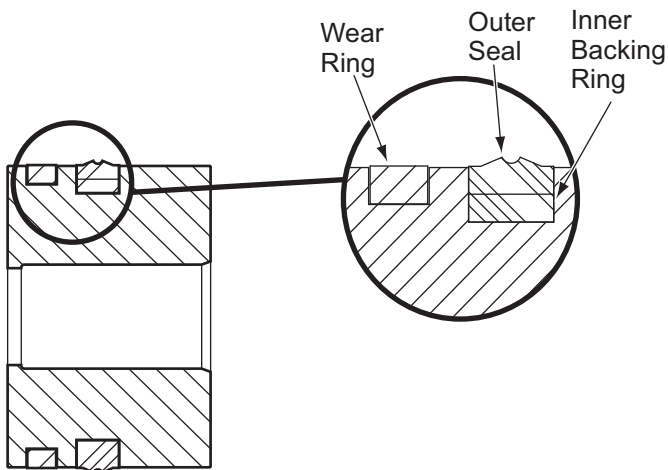

3. Remove piston from rod and assemble piston components as shown.

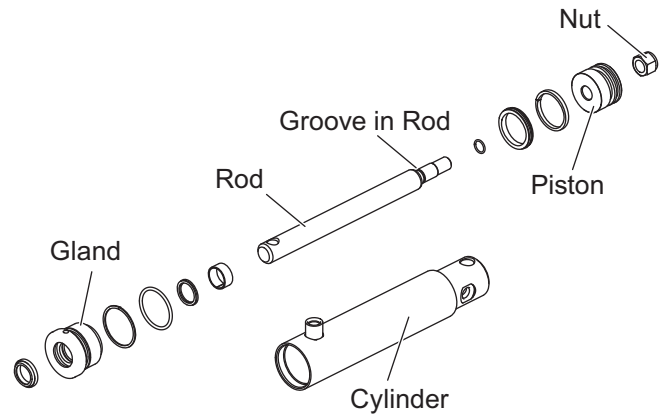

4. Assemble gland to threaded end of rod. Do not slide gland over cross hole in rod.
5. Reassemble piston to rod and tighten nut to 100–120 ft-lb.
6. Assemble O-ring into groove on rod. Use tape or other protection on threads.
7. Apply bead of medium-strength threadlocker all around threads of gland.
8. Lubricate piston seals and inside of cylinder.
9. Press rod assembly into cylinder and tighten gland to 30–40 ft-lb.

DOUBLE-ACTING RAM SEALS

The company reserves the right under its product improvement policy to change construction or design details and furnish equipment when so altered without reference to illustrations or specifications used.

Printed in U.S.A.
