

# ORIFICE PLATE INSTALLATION INSTRUCTIONS

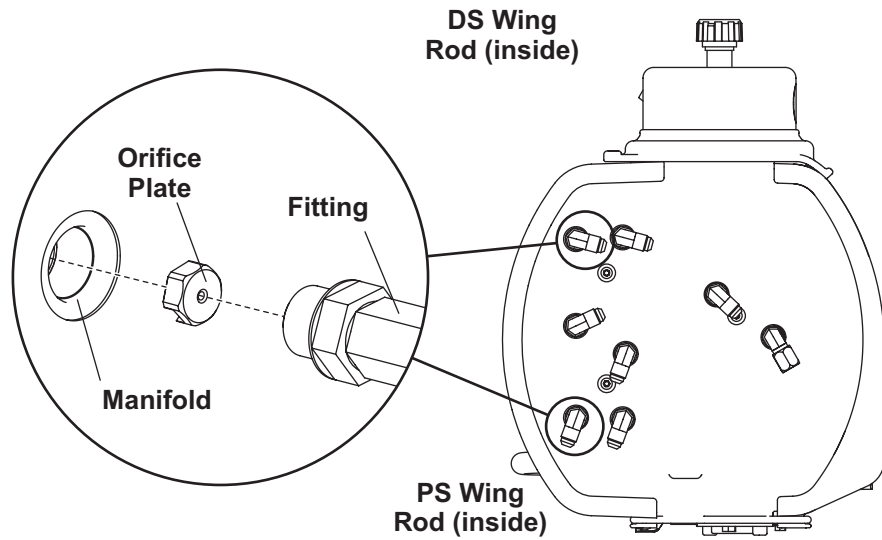

Lit. No. 49470, Rev. 00

Printed in U.S.A.

August 1, 2007

# ORIFICE PLATE INSTALLATION INSTRUCTIONS

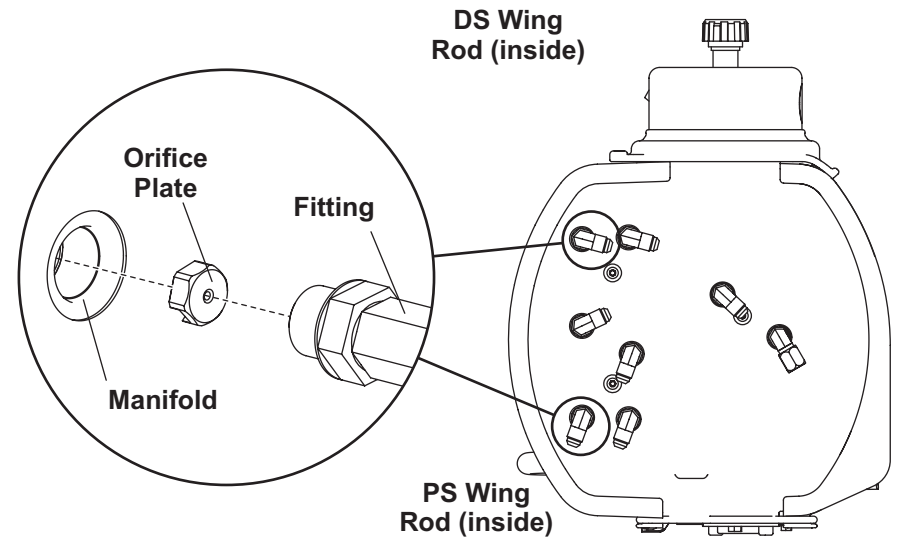

Lit. No. 49470, Rev. 00

Printed in U.S.A.

August 1, 2007

# ORIFICE PLATE INSTALLATION INSTRUCTIONS

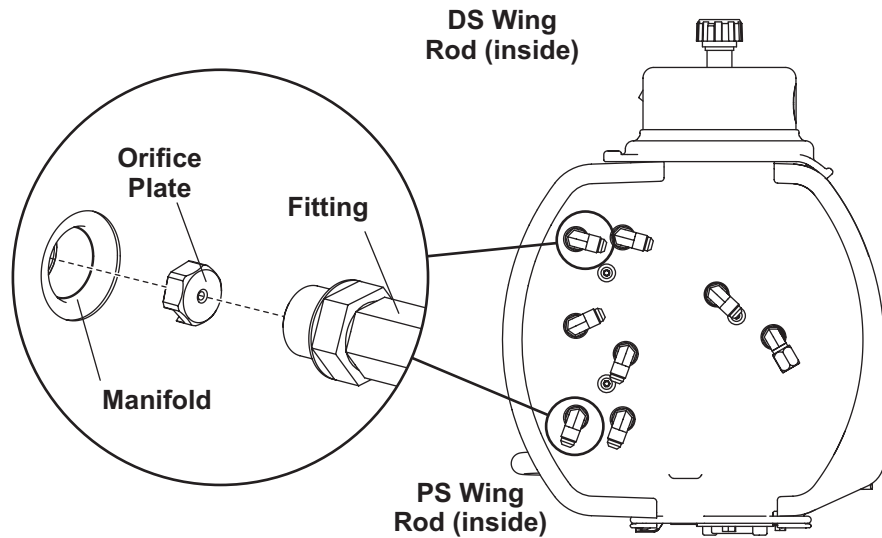

Lit. No. 49470, Rev. 00

Printed in U.S.A.

August 1, 2007

# ORIFICE PLATE INSTALLATION INSTRUCTIONS

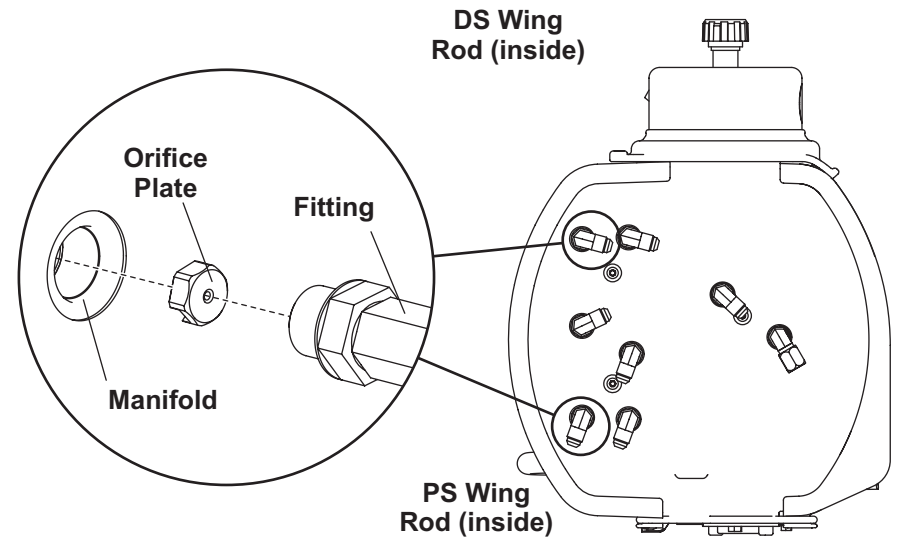

Lit. No. 49470, Rev. 00

Printed in U.S.A.

August 1, 2007

## ORIFICE PLATE INSTALLATION INSTRUCTIONS

Do not use thread sealant/tape on hoses and fittings. This could damage the product. Install all fittings into rams and hydraulic unit using the following procedure and fitting orientation illustrations:

1. Remove the plug from the ram or manifold port. Use a rag to catch residual fluid when removing manifold plugs.
2. Turn the jam nut on the fitting as far back as possible.
3. Lubricate the O-ring with clean hydraulic fluid.
4. Install the hexagonal orifice plate under each wing rod fitting as shown below. The slot in the orifice plate must face the manifold.
5. Screw the fitting into the port by hand as far as it will go. The washer should contact the port face and the shoulder of the jam nut threads.
6. Unscrew the fitting to the proper position, no more than one full turn.
7. Use one wrench to hold the fitting body in position and tighten the jam nut with another wrench until the washer again contacts the port face. Tighten 1/8–1/4 turn to lock fitting in place.

---

Lit. No. 49470, Rev. 00

Printed in U.S.A.

August 1, 2007

## ORIFICE PLATE INSTALLATION INSTRUCTIONS

Do not use thread sealant/tape on hoses and fittings. This could damage the product. Install all fittings into rams and hydraulic unit using the following procedure and fitting orientation illustrations:

1. Remove the plug from the ram or manifold port. Use a rag to catch residual fluid when removing manifold plugs.
2. Turn the jam nut on the fitting as far back as possible.
3. Lubricate the O-ring with clean hydraulic fluid.
4. Install the hexagonal orifice plate under each wing rod fitting as shown below. The slot in the orifice plate must face the manifold.
5. Screw the fitting into the port by hand as far as it will go. The washer should contact the port face and the shoulder of the jam nut threads.
6. Unscrew the fitting to the proper position, no more than one full turn.
7. Use one wrench to hold the fitting body in position and tighten the jam nut with another wrench until the washer again contacts the port face. Tighten 1/8–1/4 turn to lock fitting in place.

---

Lit. No. 49470, Rev. 00

Printed in U.S.A.

August 1, 2007

## ORIFICE PLATE INSTALLATION INSTRUCTIONS

Do not use thread sealant/tape on hoses and fittings. This could damage the product. Install all fittings into rams and hydraulic unit using the following procedure and fitting orientation illustrations:

1. Remove the plug from the ram or manifold port. Use a rag to catch residual fluid when removing manifold plugs.
2. Turn the jam nut on the fitting as far back as possible.
3. Lubricate the O-ring with clean hydraulic fluid.
4. Install the hexagonal orifice plate under each wing rod fitting as shown below. The slot in the orifice plate must face the manifold.
5. Screw the fitting into the port by hand as far as it will go. The washer should contact the port face and the shoulder of the jam nut threads.
6. Unscrew the fitting to the proper position, no more than one full turn.
7. Use one wrench to hold the fitting body in position and tighten the jam nut with another wrench until the washer again contacts the port face. Tighten 1/8–1/4 turn to lock fitting in place.

---

Lit. No. 49470, Rev. 00

Printed in U.S.A.

August 1, 2007

## ORIFICE PLATE INSTALLATION INSTRUCTIONS

Do not use thread sealant/tape on hoses and fittings. This could damage the product. Install all fittings into rams and hydraulic unit using the following procedure and fitting orientation illustrations:

1. Remove the plug from the ram or manifold port. Use a rag to catch residual fluid when removing manifold plugs.
2. Turn the jam nut on the fitting as far back as possible.
3. Lubricate the O-ring with clean hydraulic fluid.
4. Install the hexagonal orifice plate under each wing rod fitting as shown below. The slot in the orifice plate must face the manifold.
5. Screw the fitting into the port by hand as far as it will go. The washer should contact the port face and the shoulder of the jam nut threads.
6. Unscrew the fitting to the proper position, no more than one full turn.
7. Use one wrench to hold the fitting body in position and tighten the jam nut with another wrench until the washer again contacts the port face. Tighten 1/8–1/4 turn to lock fitting in place.

---

Lit. No. 49470, Rev. 00

Printed in U.S.A.

August 1, 2007