



Fisher Engineering

50 Gordon Drive, Rockland, Maine 04841-2139 • www.fisherplows.com

27500, 28000, 28100-1
28500, 29000, 29100-1
75000, 75500

August 1, 2012
Lit. No. 49593, Rev. 02

Minute²
Mount
SYSTEM

XBLADETM

HD Series & XBLADETM Snowplows

Installation Instructions

⚠ CAUTION

Read this document before installing the snowplow.

⚠ CAUTION

See your FISHER[®] outlet/Web site for specific vehicle application recommendations before installation. The Kit Selection Guide has specific vehicle and snowplow requirements.

SAFETY DEFINITIONS

⚠ WARNING

Indicates a potentially hazardous situation that, if not avoided, could result in death or serious personal injury.

⚠ CAUTION

Indicates a potentially hazardous situation that, if not avoided, may result in minor or moderate injury. It may also be used to alert against unsafe practices.

NOTE: Indicates a situation or action that can lead to damage to your snowplow and vehicle or other property. Other useful information can also be described.

WARNING/CAUTION AND INSTRUCTION LABELS

Become familiar with and inform users about the warning labels on the back of the blade and the instruction label on the headgear.

NOTE: If labels are missing or cannot be read, see your sales outlet.

Warning/Caution Label

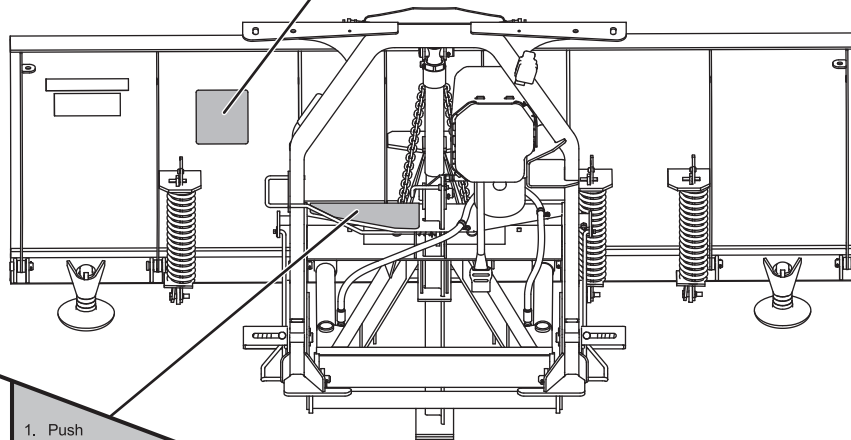
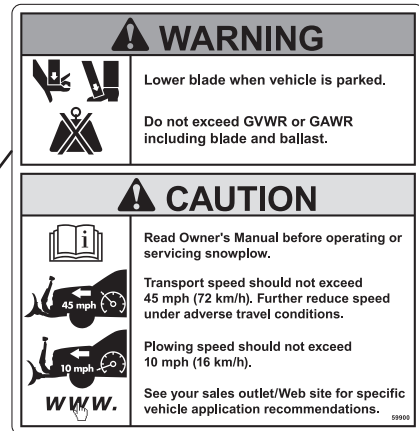

Instruction Label

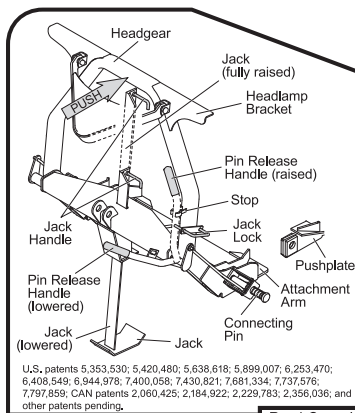

1. Push **Pin Release Handle** down to pull out **Connecting Pins**.
2. Drive vehicle slowly to engage **Pushplates** into **Attachment Arms**.
3. Stand in front of blade. Fully raise **Pin Release Handle** to release **Connecting Pins**.
4. Push **Headgear** toward vehicle to allow **Connecting Pins** to fully engage **Pushplates**. If unable to push **Headgear** from in front of blade, stand in front of **Headgear** on driver side and push **Headlamp Bracket**.
5. Pull out **Jack Lock**. Push **Pin Release Handle** into **Stop**.
6. While holding **Jack Lock** out, use **Jack Handle** to raise **Jack** fully. Release **Jack Lock**.
7. Attach all electrical connectors.

Read Owner's Manual for complete instructions.

1. Place control in Lower/Float to put blade down.
2. Pull and hold **Jack Lock** out. **Jack** will drop to ground. Then pull **Pin Release Handle** away from **Stop** and **Jack Lock**. Release **Jack Lock**. Verify **Jack** is locked by trying to lift **Jack**.
3. Stand in front of blade. While pushing **Headgear** toward vehicle with left hand, push **Pin Release Handle** down to disengage **Connecting Pins**. Make sure **Connecting Pins** are fully retracted. If unable to push **Headgear** from in front of blade, stand in front of **Headgear** on driver side and push **Headlamp Bracket**.
4. Detach all electrical connectors.

ATTACH

DETACH

27451

SAFETY PRECAUTIONS

Improper installation and operation could cause personal injury and/or equipment and property damage. Read and understand labels and the Owner's Manual before installing, operating or making adjustments.

⚠ WARNING

Lower the blade when the vehicle is parked. Temperature changes could change hydraulic pressure, causing the blade to drop unexpectedly or damaging hydraulic components. Failure to do this could result in serious personal injury.

⚠ WARNING

The driver shall keep bystanders clear of the blade when it is being raised, lowered or angled. Do not stand between the vehicle and the blade or within 8 feet of a moving blade. A moving or falling blade could cause personal injury.

⚠ WARNING

Keep hands and feet clear of the blade and A-frame when mounting or removing the snowplow. Moving or falling assemblies could cause personal injury.

⚠ WARNING

Do not exceed GVWR or GAWR including blade and ballast. The rating label is found on driver-side vehicle door cornerpost.

⚠ WARNING

To prevent accidental movement of the blade, always turn the control OFF whenever the snowplow is not in use. The power indicator light will turn OFF.

⚠ WARNING

Remove blade assembly before placing vehicle on hoist.

⚠ CAUTION

Refer to the current Kit Selection Guide for minimum vehicle recommendations and ballast requirements.

HYDRAULIC SAFETY

⚠ WARNING

Hydraulic fluid under pressure can cause skin injection injury. If you are injured by hydraulic fluid, get medical attention immediately.

- Always inspect hydraulic components and hoses before using. Replace any damaged or worn parts immediately.
- If you suspect a hose leak, DO NOT use your hand to locate it. Use a piece of cardboard or wood.

FUSES

The FISHER® electrical and hydraulic systems contain several blade-style automotive fuses. If a problem should occur and fuse replacement is necessary, the replacement fuse must be of the same type and amperage rating as the original. Installing a fuse with a higher rating can damage the system and could start a fire. Fuse Replacement, including fuse ratings and locations, is located in the Maintenance section of the Owner's Manual.

PERSONAL SAFETY

- Remove the ignition key and put the vehicle in park or in gear to prevent others from starting the vehicle during installation or service.
- Wear only snug-fitting clothing while working on your vehicle or snowplow.
- Do not wear jewelry or a necktie, and secure long hair.
- Wear safety goggles to protect your eyes from battery acid, gasoline, dirt and dust.
- Avoid touching hot surfaces such as the engine, radiator, hoses and exhaust pipes.
- Always have a fire extinguisher rated BC handy, for flammable liquids and electrical fires.

FIRE AND EXPLOSION

WARNING

Gasoline is highly flammable and gasoline vapor is explosive. Never smoke while working on vehicle. Keep all open flames away from gasoline tank and lines. Wipe up any spilled gasoline immediately.

Be careful when using gasoline. Do not use gasoline to clean parts. Store only in approved containers away from sources of heat or flame.

CELL PHONES

A driver's first responsibility is the safe operation of the vehicle. The most important thing you can do to prevent a crash is to avoid distractions and pay attention to the road. Wait until it is safe to operate Mobile Communication Equipment such as cell phones, text messaging devices, pagers or two-way radios.

VENTILATION

WARNING

Vehicle exhaust contains lethal fumes. Breathing these fumes, even in low concentrations, can cause death. Never operate a vehicle in an enclosed area without venting exhaust to the outside.

BATTERY SAFETY

CAUTION

Batteries normally produce explosive gases, which can cause personal injury. Therefore, do not allow flames, sparks or lit tobacco to come near the battery. When charging or working near a battery, always cover your face and protect your eyes, and also provide ventilation.

- Batteries contain sulfuric acid, which burns skin, eyes and clothing.
- Disconnect the battery before removing or replacing any electrical components.

NOISE

Airborne noise emission during use is below 70 dB(A) for the snowplow operator.



VIBRATION

Operating snowplow vibration does not exceed 2.5 m/s² to the hand-arm or 0.5 m/s² to the whole body.

TORQUE CHART

CAUTION

Read instructions before assembling. Fasteners should be finger tight until instructed to tighten according to the torque chart. Use standard methods and practices when attaching snowplow, including proper personal protective safety equipment.

Recommended Fastener Torque Chart (ft-lb)			
Size	Torque		
	 SAE Grade 2	 SAE Grade 5	 SAE Grade 8
1/4-20	6	9	13
5/16-18	11	18	28
3/8-16	19	31	46
3/8-24	24	46	68
7/16-14	30	50	75
1/2-13	45	75	115
9/16-12	66	110	165
5/8-11	93	150	225
3/4-10	150	250	370
7/8-9	150	378	591
1-8	220	583	893
Metric Grade 8.8 (ft-lb)			
Size	Torque	Size	Torque
M 6	7	M 12	60
M 8	17	M 14	95
M 10	35	M 16	155
These torque values apply to fasteners except those noted in the instruction.			

HEADGEAR TO A-FRAME ASSEMBLY

NOTE: For easier assembly and installation, vehicle and all snowplow components should be on a smooth, level, hard surface, such as concrete.

1. Set aside the blade guides and parts bag. The vehicle electrical harnesses and the Owner's Manual packet are in the bag with the headlamp box.
2. Remove the packaging hardware securing the headgear to the A-frame, except the clevis pins and red shipping brackets.
3. Remove the blocking and hardware securing the A-frame to the pallet.
4. While supporting the headgear, remove and retain the four pins, and discard the red shipping brackets.

5. Align the holes in the headgear assembly with the middle hole in the A-frame assembly. Attach the A-frame to the headgear with two step pins and 1/4" x 1-1/2" cotter pins. Insert the step pins from the outside of the headgear. Verification of proper A-frame position will be made during final adjustments.

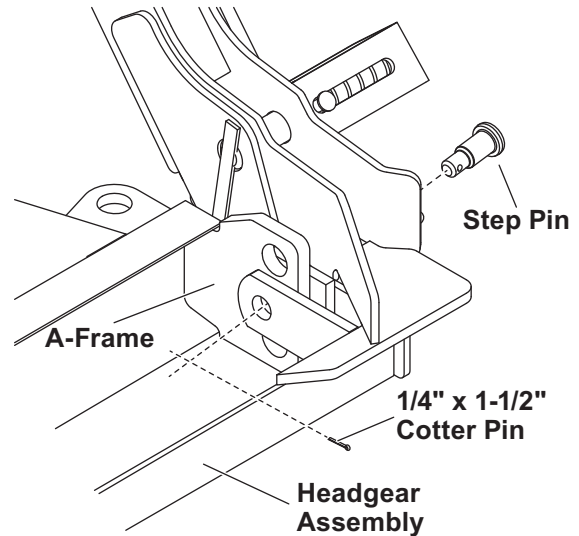

A-FRAME TO BLADE ASSEMBLY

1. Align the pivot-pin hole on the A-frame with the pivot-pin hole on the blade.
2. Install the pivot pin from the top. Secure with a 1/4" x 2" slotted spring pin at the bottom.
3. With the blade in normal operating position, pull the jack lock and lower the jack leg to support the headgear. Release the jack lock to hold the jack in position.

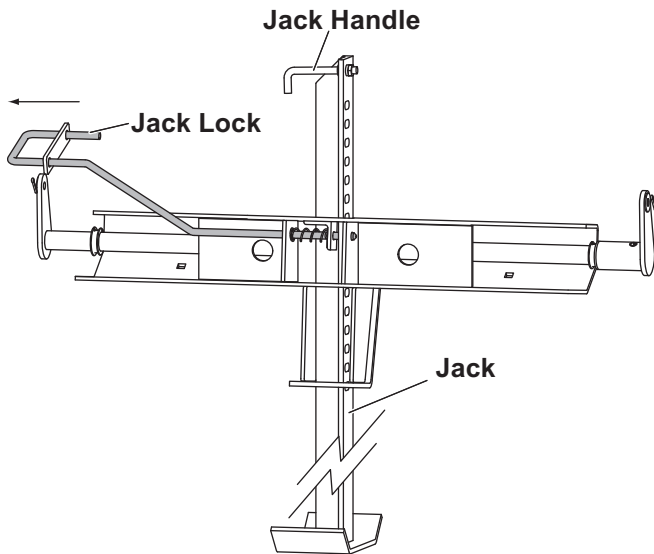

5. Align the angle ram rods with the angle ram holes on the blade, and attach using two 1" x 4-3/4" clevis pins, installed from the top. Secure with 1/4" x 1-1/2" cotter pins.

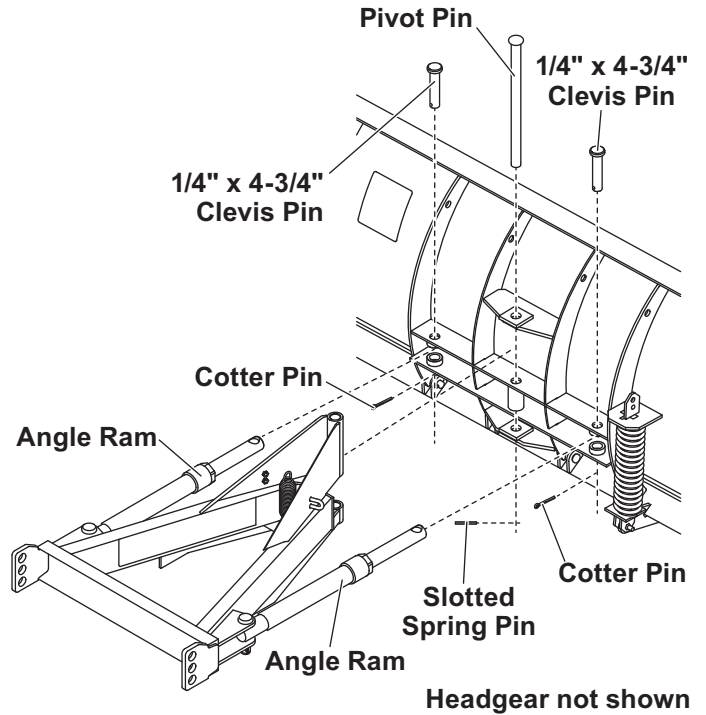

4. Remove the protective packaging from the angle rams.

6. Install the blade guides.

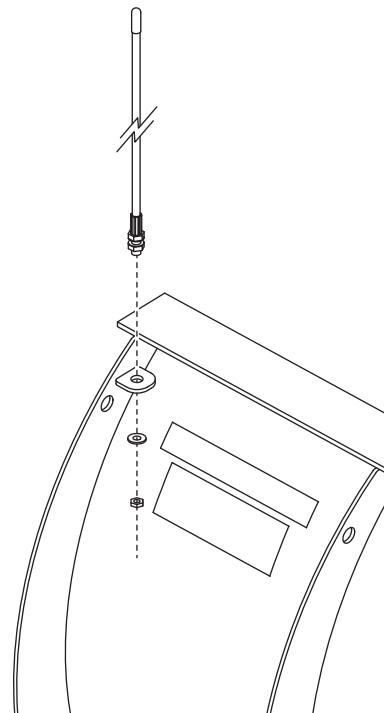

HYDRAULIC UNIT

⚠ WARNING

Keep 8' clear of the blade when it is being raised, lowered or angled. Do not stand between vehicle and blade or directly in front of the blade. If the blade hits or drops on you, you could be seriously injured.

The HD Series and XBLADE™ snowplow hydraulic system comes from the factory pre-assembled, partially filled and fully tested.

1. Attach the snowplow to the vehicle according to the instructions on the headgear.
2. Remove the cover of the hydraulic unit.
3. Remove and discard the factory-installed pipe plug from the breather port. Install the 90° elbow into the port, with the elbow pointing up.

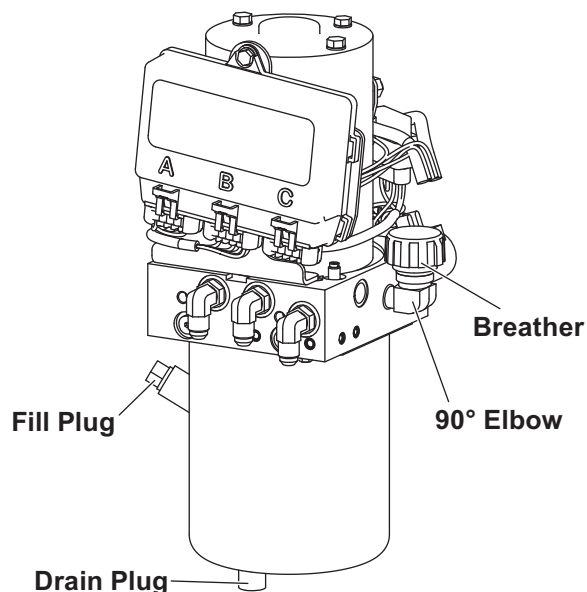

4. Install the breather into the elbow.
5. Replace the cover.

⚠ WARNING

To prevent accidental movement of the blade, always turn the control OFF whenever the snowplow is not in use. The power indicator light will turn OFF.

6. Turn the control ON and completely angle the blade to the left and right several times. Raise and lower the snowplow several times. Activate the control FLOAT function and manually collapse the lift ram all the way. Turn the control OFF.

⚠ CAUTION

Do not mix different types of hydraulic fluid. Some fluids are not compatible and may cause performance problems and product damage.

7. Remove the fill plug and check the fluid level. With the lift ram fully retracted, the fluid level should reach the fill hole. If additional fluid is needed, fill the reservoir with FISHER® EZ Flow Hydraulic Fluid to -40°F (-40°C), or other fluid conforming to Military Specification MIL-H-5606A, such as Mobil Aero HFA or Shell AeroShell® Fluid 4.

NOTE: Remove fill plug slowly to relieve any pressure in reservoir.

8. Replace and tighten the fill plug.

FLUID CAPACITY

- Insta-Act® Unit Reservoir 1-3/4 quarts
- Insta-Act System Total 2-3/8 to 2-3/4 quarts

HEADLAMPS

⚠ WARNING

Your vehicle must be equipped with snowplow headlamps and directional lights.

Headlamps, hardware and instructions are found in the headlamp box.

1. Attach the headlamps to the hole and slot in the headgear light bracket by following the instructions included with the headlamps.
2. Secure the snowplow harnesses and cables to the headgear as shown.

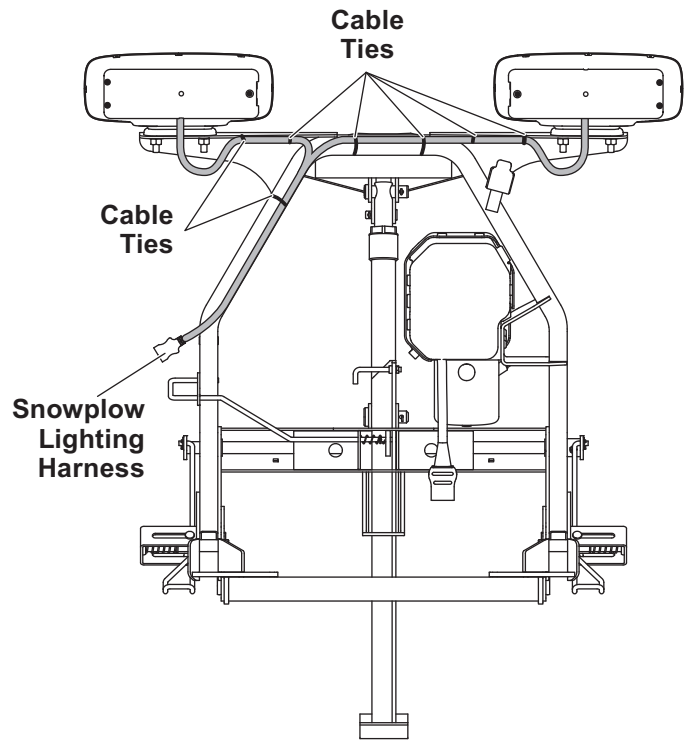

FINAL ADJUSTMENTS

⚠ WARNING

Keep 8' clear of the blade when it is being raised, lowered or angled. Do not stand between vehicle and blade or directly in front of the blade. If the blade hits or drops on you, you could be seriously injured.

For XBLADE™ snowplows only: To prevent the blade from blocking the snowplow headlamps during travel, adjust the chain to the minimum length indicated in the chart below. (Chain will be slack.)

A-Frame Adjustment Holes	Minimum Dimension "A"
Top	29.0"
Middle	28.5"
Bottom	28.0"

Lift Chain

1. With the snowplow attached to a properly ballasted vehicle and the blade lowered to the ground, the A-frame should be parallel with the ground. If not, reposition the A-frame using the upper or lower A-frame assembly holes.
2. Remove and retain the passenger-side lift chain U-bolt.

For HD snowplows only: Adjust the length of the lift chain so the A-frame hits the lower portion of the headgear when the lift ram is fully extended (10").

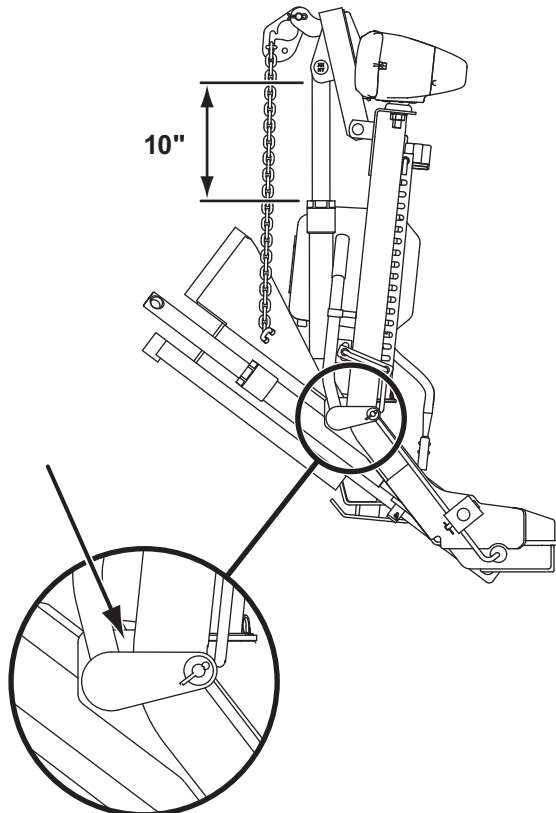

Shown with blade raised

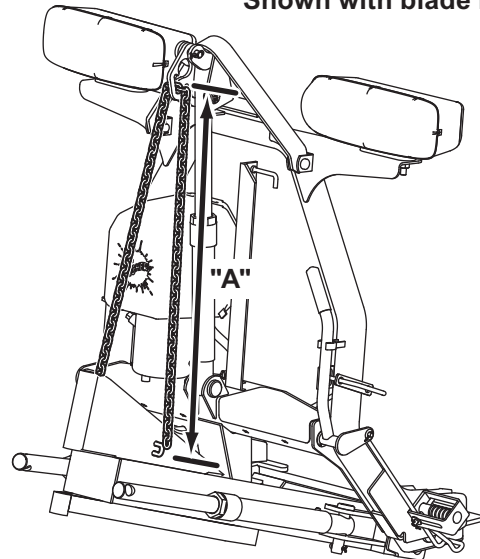

3. Reattach the loose end of the lift chain to the passenger's side of the A-frame with the retained U-bolt and locknuts. Chain must be the same length used in Step 2.
4. Fully tighten the U-bolts, with the chain oriented in the direction of lift, before lifting the blade.

Keep first link oriented in direction of lift when attaching U-bolt.

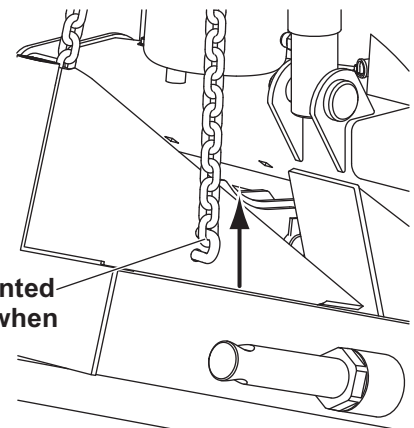

Connecting Link and Lift Chain Spring

When the blade is lowered, the lift chain spring provides slack in the lift chain for ease of mounting and dismounting the blade.

Your snowplow application may use either a lap link or a quick link to connect the lift chain and spring.

Lap Link

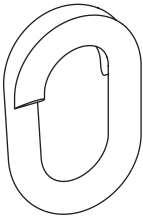

Quick Link

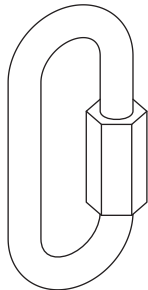

The lift chain spring is installed at the factory in the lift chain link number indicated in the chart below.

Snowplow	Number of Links from Driver-Side U-Bolt	
	Lap Link	Quick Link
HD/XBLADE™	6	7

However, due to variations in vehicle frame height, it may be necessary to adjust the spring location to ensure optimal performance.

If you encounter mounting or dismounting difficulty, the attachment point of the connecting link and spring can be changed to a link on the lift chain that will add or remove slack from the lift chain.

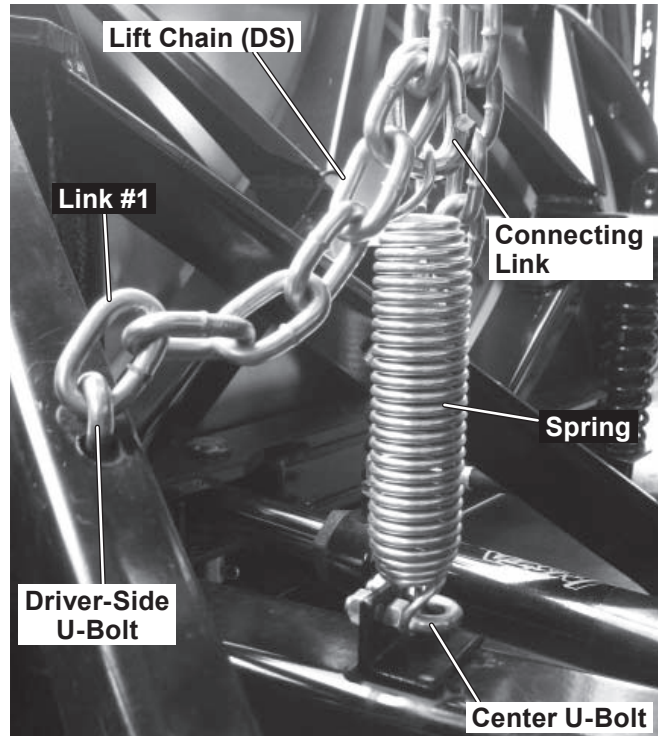

With the snowplow attached to a properly ballasted vehicle, make one of the following adjustments:

If there is not enough slack in the lift chain, there will be difficulty getting the connecting pins to engage the vehicle pushplates while pushing back on the headgear. Adjust the connecting link *up* one link from the factory setting.

If there is too much slack in the lift chain, adjust the connecting link *down* one link from the factory setting.

Moving the connecting link more than one chain link higher or lower than the factory installed location is not recommended.

VEHICLE LIGHTING CHECK

1. Verify the operation of all vehicle front lighting prior to connecting the snowplow harness.
2. Check the operation of the snowplow lights with snowplow mounted to vehicle and all harnesses connected.

Turn signals and parking lamps

Parking lamps ON:

- Both vehicle and snowplow parking lamps should be ON at the same time.

Driver-side turn signal ON:

- Both vehicle and snowplow driver-side turn signal lamps should flash at the same time.

Passenger-side turn signal ON:

- Both vehicle and snowplow passenger-side turn signal lamps should flash at the same time.

Headlamps

Move the vehicle headlamp switch to the "ON" position. Connecting and disconnecting the snowplow lighting harness plug should switch the lights between vehicle and snowplow as follows:

Snowplow lighting harness DISCONNECTED:

- Vehicle headlamps should be ON.
- Snowplow headlamps should be OFF.

Snowplow lighting harness CONNECTED:

- Snowplow headlamps should be ON.
- Vehicle headlamps should be OFF.

The dimmer switch should toggle headlamps between high and low beams. The high beam indicator on the dash should light when headlamps are placed in high beam.

Daytime Running Lamps (DRLs)

An operational check of the vehicle and snowplow DRLs will depend on the vehicle model, vehicle DRL system and type of Isolation Module installed. Due to the variations in the OEM DRL systems and the different Isolation Module

options available, checking the functionality of the snowplow DRLs will depend on the type of module installed on the vehicle.

With the headlamp switch OFF, activate the vehicle DRLs.

Snowplow lighting harness DISCONNECTED:

- Vehicle DRLs should be ON.
- Snowplow headlamps should be OFF.

Snowplow lighting harness CONNECTED and vehicle in DRL mode:

- Check snowplow DRL function per the type of Isolation Module installed.

Refer to the Mechanic's Guide for information on the Isolation Module DRL functions.

Control power indicator light

The snowplow plugs **do** need to be connected to the vehicle harness connectors. The control power indicator light should light whenever the control ON/OFF switch and the ignition (key) switches are both in the "ON" position.

3. Connect all snowplow and vehicle harnesses. Raise the snowplow and aim the snowplow headlamps according to the Snowplow Headlamp Beam Aiming Instructions included with the headlamps, and any state or local regulations.
4. Check the aim of the vehicle headlamps with the snowplow removed.

CAUTION

On 2-plug electrical systems, plug covers shall be used whenever snowplow is disconnected. Vehicle Battery Cable is 12-volt unfused source.

5. When the snowplow is removed from the vehicle, install plug covers on the vehicle battery cable and lighting harness. Insert the snowplow battery cable and lighting harness into the cable boot on the snowplow.

OWNER'S MANUAL PACKET

If the completed snowplow will be delivered immediately, the Owner's Manual should be reviewed with and given to the purchaser according to the snowplow checklist.

If the snowplow is completed prior to delivery to the purchaser, attach the Owner's Manual Packet to the electrical cable of the cab control for safekeeping.

Fisher Engineering reserves the right under its product improvement policy to change construction or design details and furnish equipment when so altered without reference to illustrations or specifications used. Fisher Engineering or the vehicle manufacturer may require or recommend optional equipment for snow removal. Do not exceed vehicle ratings with a snowplow. Fisher Engineering offers a limited warranty for all snowplows and accessories. See separately printed page for this important information. The following are registered (®) or unregistered (™) trademarks of Douglas Dynamics, L.L.C.: FISHER®, Insta-Act®, Minute Mount® 2, XBLADE™.

Printed in U.S.A.
