

Installation Instructions

Current style armatures with a bushing on the drive end use only the thick fiber washer. (See Figure 1.) Early style armatures with a retaining ring on the drive end use a thin steel washer between the retaining ring and the thick fiber washer. (See Figure 2.) Always replace retaining ring when replacing thrust washers. Install retaining ring with sharp edges toward armature windings. Make sure retaining ring is fully seated in shaft groove.

1. Loosen motor thru-bolts and nut on positive stud. Gently tap end cap loose. Tap stud bushing out of slot in cap and remove cap with bolts. Remove thrust washers from commutator end of armature in order.
2. Remove motor housing and armature together from flange or valve block. Do not allow armature to fall out of brushes. Remove thrust washer(s) from drive end of armature in order.
3. Reassemble motor with new thrust washers of the same size and quantity in the same order as removed. Tighten thru-bolts to 55–65 in-lb. Tighten positive stud nut and battery cable nuts to 50–60 in-lb. Armature should have a slight amount of end play when motor is assembled to flange or valve block.

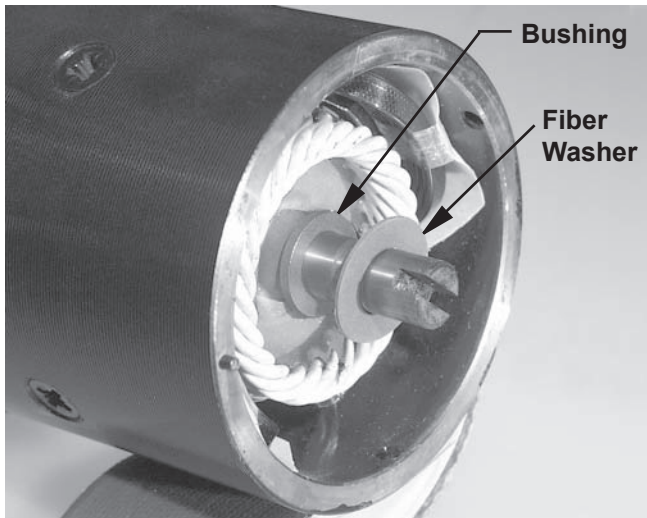

Figure 1

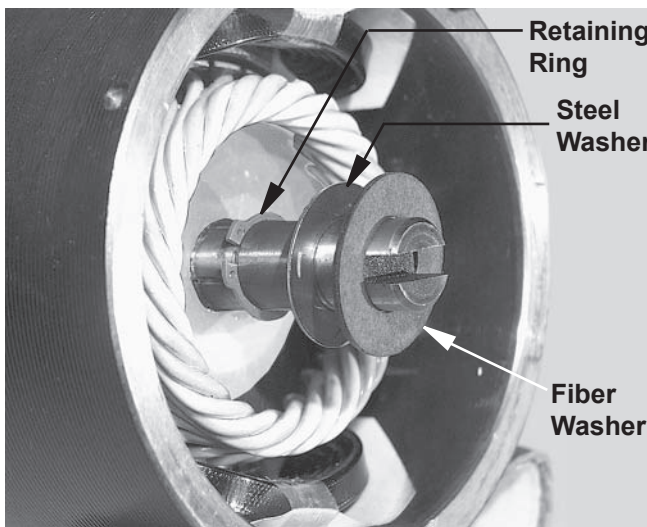

Figure 2

Copyright © 2008 Douglas Dynamics, L.L.C. All rights reserved. This material may not be reproduced or copied, in whole or in part, in any printed, mechanical, electronic, film or other distribution and storage media, without the written consent of the company. Authorization to photocopy items for internal or personal use by the company's outlets is granted.

The company reserves the right under its product improvement policy to change construction or design details and furnish equipment when so altered without reference to illustrations or specifications used herein. The company and the vehicle manufacturer may require and/or recommend optional equipment for snow removal. The company offers a limited warranty on the snowplow and accessories. See separately printed page for this important information.

Printed in U.S.A.
