

Heavy Duty
Common Attachments

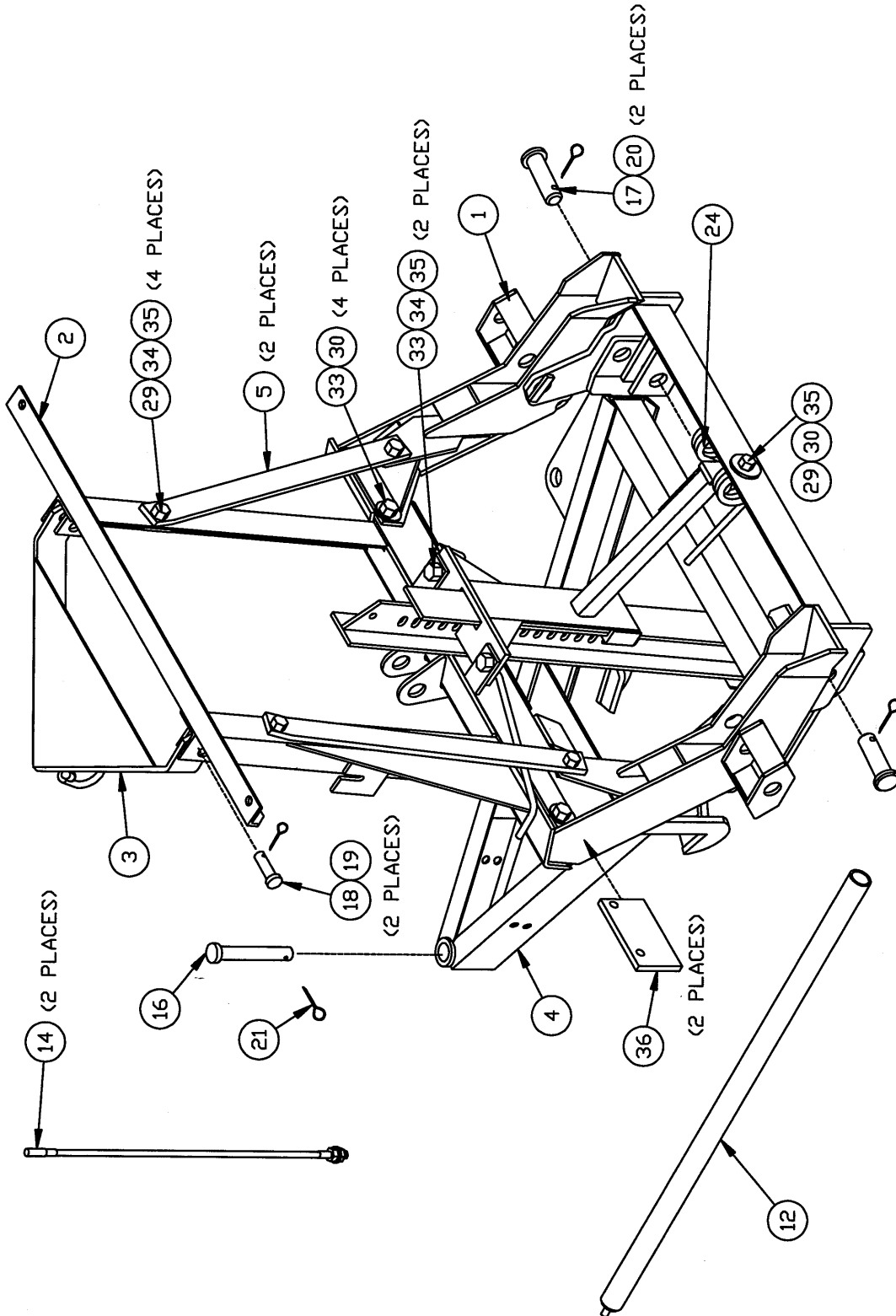

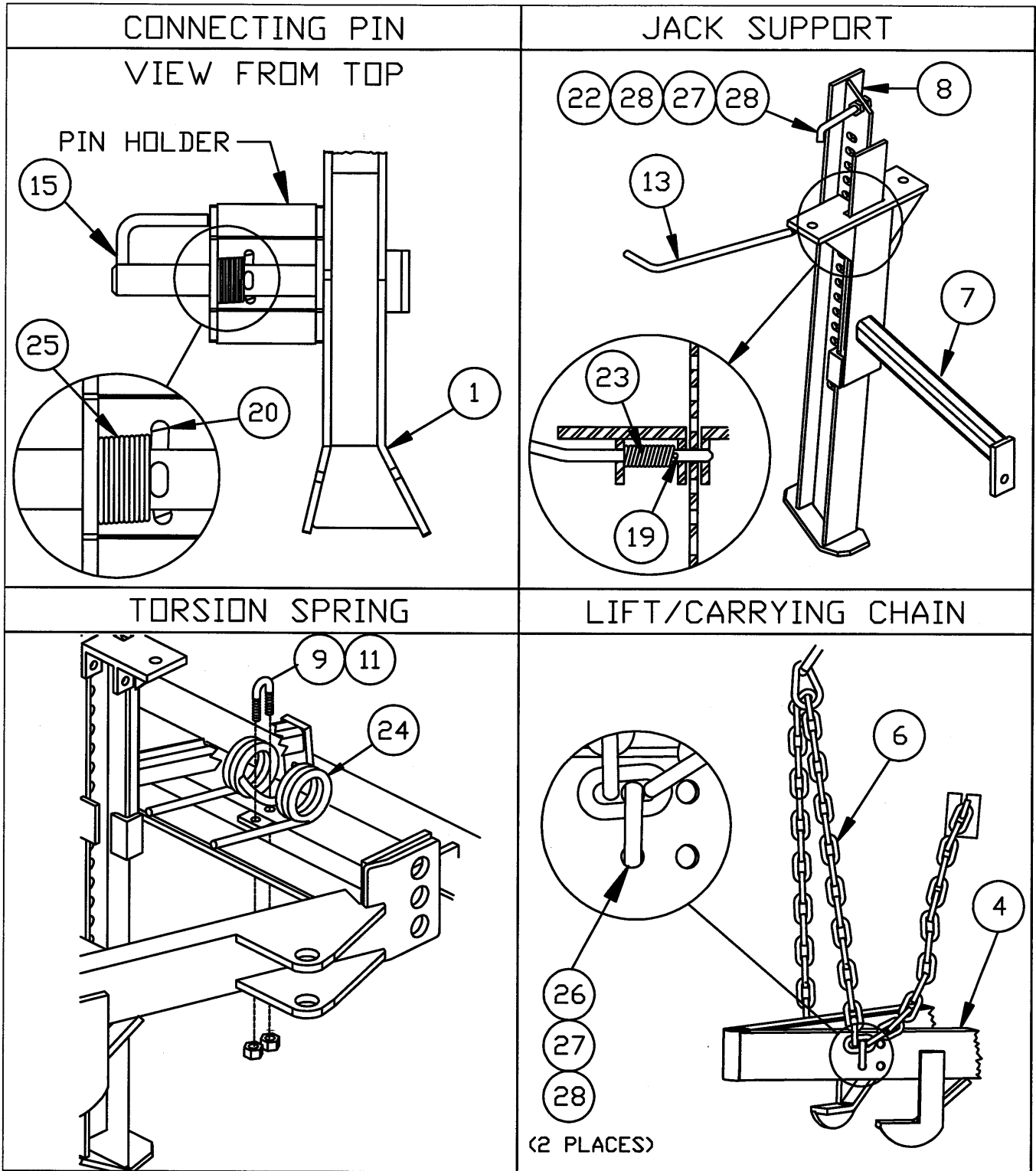

Parts List

Ref #	Part #	Qty	Description	Ref #	Part #	Qty	Description
1	8533	1	Lower Gear	22	*8173	1	Jack Handle
2	8480	1	Head Gear	23	*7794	1	Spring - 1/2 OD x 2"
3	21920	1	Lift Arm	24	!20182	1	Torsion Spring-3-coil
4	8627	1	A-Frame Assembly - HD	25	*821	2	Spring - 1 ID x 3-1/2"
5	8514	2	Head Gear Brace (19-3/4 OAL)	26	*90453	2	3/8-16" U-bolt RD bend G5 YZP
6	7309	1	Chain 5/16 x 108"	27	*90361	5	3/8" Lock Washer
7	20488	1	Jack Support - HD	28	*90334	6	3/8"-16 Nut
8	20491	1	Jack Leg - HD	29	*90210	5	1/2-13 x 1-1/2" Gr. 5 Cap Screw
9	!90571	1	3/8"-16 U-Bolt Gr. 2				
11	!90352	2	3/8"-16 Locknut	30	*90572	5	1/2" Gr. 8 Flat Washer
12	8551	1	Release Rod - HD & RD	31	*20183	1	Tab
13	8499	1	Jack Lever - HD & RD	32	*20185	1	Torsion Spring Kit
14	A5108	2	Flexible Blade Guide	33	*90575	7	1/2-13 x 1-1/4" Gr. 5 Cap Screw
15	*6815	2	Connecting Pin w/ handle	34	*90364	7	1/2" Lock Washer
16	*6817	1	Pivot Pin - 1 x 6"	35	*90337	7	1/2"-13 Nut
17	*6814	2	Clevis Pin - 1 x 3-5/16"	36	8498	2	Bolting Bar
18	*4289	2	3/4 x 1-7/8" Machine Pin	26,27	A6148K	2	U-Bolt Assembly
19	*90658	3	5/32 x 1-1/4" Cotter Pin	,28			
20	*90601	4	1/4 x 1-1/2" Cotter Pin	15,25	6920	2	Connecting Pin Assembly
21	*90013	1	1/4 x 2" Cotter Pin	,20			



! Part of 20185 Torsion Spring Kit

* Part of 8553 Bolt Bag

Installation Instructions

NOTE: Installation of angle cylinders and A-Frame to blade are covered in the hydraulic instructions, Section 1.

- Attach the A-frame (4) to the blade with the 1 x 6" pivot pin (16). The pivot pin should be inserted down through the blade and A-frame and secured with a 1/4 x 2" cotter pin (21). After installing A-frame to blade, place a 1-1/2" block in the center of the A-frame rear cross member. **A-frame cross-member should be parallel to the blade.**
- Install a 3/8" U-bolt (26) through a link in the lift/carrying chain (6) 32" from the end—see lift/carrying chain illustration. Attach U-bolt and chain to the two front holes on driver side of A-frame (4) with two 3/8" lock washers (27) and nuts (28). Do not fully tighten. **The other end of the lift chain will be attached to passenger side of A-frame after lift arm is installed.**
- To assemble connecting pins (15) to lower gear (1) insert springs (25) in pin holders—see connecting pin illustration. Then, insert connecting pin through all three holes with the pin handles toward the vehicle. Position cotter pin hole flush with inside plate, pull back on spring and install 1/4 x 1-1/2" cotter pins (20). **Bend both legs of cotter pins around connecting pins for proper clearance.**
- Place bolting bar (36) inside the head gear narrow end in first—see assembly instructions. Place head gear (2) on front end of lower gear (1). Insert four 1/2 x 1-1/4" cap screws (33) with Gr. 8 flat washers (30) through the holes in lower gear and head gear into the head gear bolting bar. Do not fully tighten.

NC FASTENER TORQUE (FT-LB)			
DIAMETER- THREADS PER INCH	GRADE		
			
	G2	G5	G8
1/4 - 20	6	9	13
5/16 - 18	11	18	28
3/8 - 16	19	31	46
7/16 - 14	30	50	75
1/2 - 13	45	75	115
9/16 - 12	66	110	165
5/8 - 11	93	150	225
3/4 - 10	150	250	370
7/8 - 9	150	378	591
1 - 8	220	583	893

5. Insert jack leg (8) up through jack support (7) and engage jack lever when four slots are visible. Install one 3/8" nut (28) on jack handle (22) and insert into top hole on jack leg. Fasten with one 3/8" lock washer (27) and nut (28).
6. Using the jack lever (13), insert the lever through the three holes on jack support (7) to clean out paint before assembling. Place jack lever spring (23) between ear and guide on jack stand (7)—see jack support illustration. Insert jack lever (13) through ear until cotter pin hole is flush with jack guide. Pull back on spring and install 5/32 x 1-1/4" cotter pin (19).
7. Install head gear braces (5) to each side of head gear—bent end on top—and to lower gear tab—bottom of braces to rear of tab—using four 1/2 x 1-1/2" cap screws (29), lock washers (34) and nuts (35). Tighten all fasteners on head gear/lower gear assembly.
8. Align holes in head gear/lower gear assembly with holes in the blocked up A-frame. Insert clevis pins (17) through ears and secure with two 1/4 x 1-1/2" cotter pins (20).
9. Pivot the upper and lower gear assembly away from the blade. Place torsion spring in center of the lower gear angle. Place 3/8" U-bolt over the loop of spring, through holes in the angle and the tab under the angle. See torsion spring illustration on page 2. Fasten with two 3/8" locknuts. Tighten both down evenly.
10. Attach jack support (7) under the tabs on rear of head gear with two 1/2 x 1-1/4" cap screws (33), lock washers (34) and nuts (35). Attach the jack support stiffener to the lower gear beam with one 1/2 x 1-1/2" cap screw (29), Gr. 8 flat washer (30) and nut (35). Tighten all fasteners.
11. Check to be certain all fasteners are tight. Attach lift arm (3) to head gear (2) with two machine pins (18) and cotter pins (19). **After hydraulic lift package has been installed tip the head gear assembly forward until stops hit A-frame.** Insert long end of chain through the loop on the lift arm and fasten end link to the two front holes in the passenger side of the A-frame using a 3/8 U-bolt (26), lock washer (27) and nut (28). Tighten. When the plow is lifted, the A-frame should hit head gear just before lift cylinder is fully extended (10"). Adjust chain in driver side if needed to accomplish the above and tighten the U-bolt. Hook 32" chain in chain plate on head gear.
12. Install the blade guides (14) on each end of the top bar on the blade.
13. See the release rod instructions, attached to the release rod, regarding its use.
14. Attach to vehicle according to the installation decal located in the upper, driver-side corner of blade.

If the back of plow lights interfere with hood grille after installation:

Loosen the two fasteners on jack leg support (7) that go to the headgear (2), the four fasteners attaching the headgear (2) to the lowergear (1) and the four fasteners on the two headgear braces (5). Raise the plow off from ground. Tighten the fastener for the braces first, then headgear to lowergear and finally the jack leg support to the headgear.