

HEADGEAR DRIVER'S SIDE

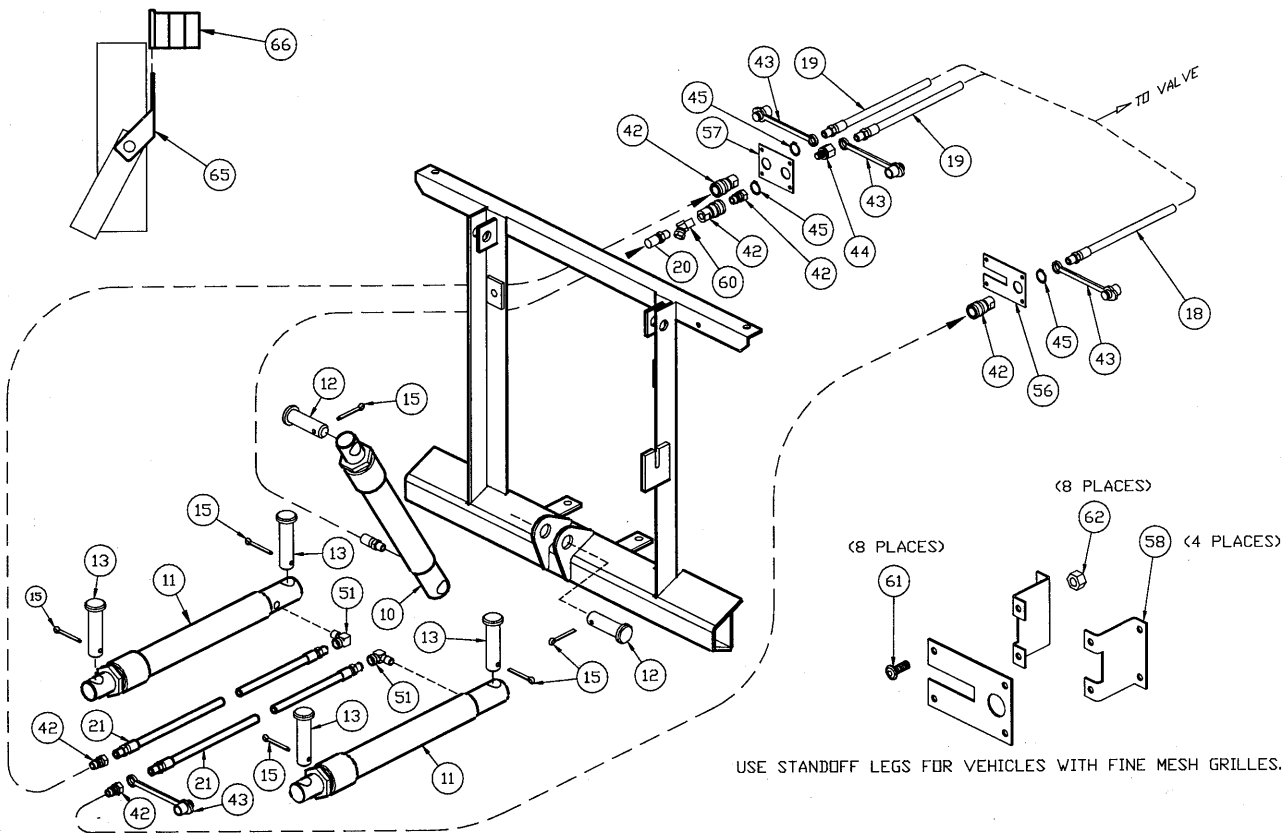

USE STANDOFF LEGS FOR VEHICLES WITH FINE MESH GRILLES.

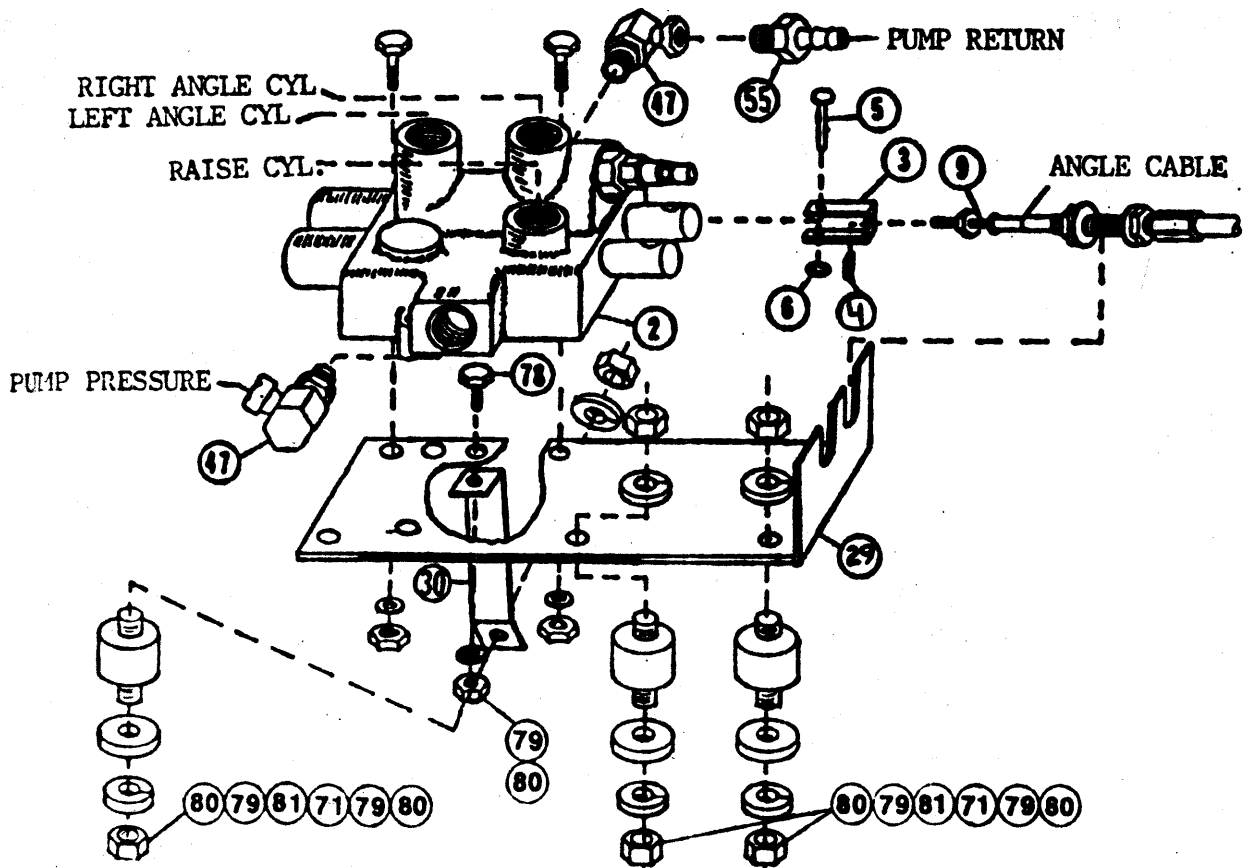

Hydraulics Parts List

Ref #	Qty	In Kit	Part #	Description	Ref #	Qty	In Kit	Part #	Description
* Part of 8723 Bolt Bag					* Part of 8723 Bolt Bag				
1	1		A2311	Pump tank assembly	50				
2	1		A4466-40	Control Valve Assembly	51	2		2780	1/4 Npt x 90 Deg Street Elbow Frgd
3	2		4483	Clevis - VM	52		1	* 2318	1/4 Npt x 90 Deg Union Elbow
4	2		4494	10-32 Square Nut - VM	53		1	*3979	3/8" Brass Bar Street Ell
5	2		4491	Clevis Pin - 3/16" x 1	54				
6	2		4493	3/16" Push Nut Zp	55	2		1658	Quill - 3/8 Nptm to 3/8 ID Hose
7	1		8764	Filter Kit	56		1	*8688	QD/Electric Plate -Short
8		1	4419	SLC Head - Belt Drive	57		1	*8686	2 QD Plate- Short
9		2	6027	45" SLC Cable	58		4	*8687	Standoff Leg
10	1		A318	1-1/2" x 10" Cylinder Assembly	59		4	*8324	Hose Tie
11	2		A3660	1-1/2" x 12" Cylinder Assembly	60		2	*8127	1/4 x 45 Deg Swivel
12	2		6814	Clevis Pin - 1 x 3-5/16	61		8	*90687	1/4" x 1/2 (NC) Button Head Sockett
13	4		6816	Anchor Pin - 1 x 4	62		8	*90350	1/4 (NC) Locknut
14					63				
15	6		90601	1/4" x 1-1/2" Cotter Pin	64				
16		1	4934	Hose - 18" Hp 1/4P - 3/8P	65		1	*8741	Bracket - Cable Boot
17		1	4471	3/8" Hose 26" Lp	66		1	*8284	Cable Boot
18		1	1711	42" Hp Hose, 9/16 O-Ring to 1/4P	67				
19		2	5262	66" Hp Hose, 9/16 O-Ring to 1/4P	68				
20		1	3074	Hose - 22" Hp 1/4P - 1/4P	69				
21		2	4424	Hose - 36" Hp 1/4P - 1/4P	70				
22					71		3	*5529	Shock Mount
23		1	1949	61" V-Belt	72		1	5704	Caution Label - Cab
24		1	20056	Drive Sheave **	73	2		3042	Grommet - Rubber, Split
25		1	3696	Pump Sheave	74	1		4477	Grommet - Split Hose
26		1	7417	Pump Bracket	75	3	2	*3666	Hose Tie, nylon 3/16 x 8
27		1	7009	Pump Bracket Brace	76		1	*8992	3" Fitting Protector
28		1	*20057	Drive Sheave Bushing .750 **	77	1		90054	5/16 x 1-1/2 (NC) Gr. 5 Cap Screw
29		1	5329	Valve Plate	78	4		*90042	5/16 x 1 (NC) Gr. 5 Cap Screw
30		1	5975	Valve Plate Brace	79	6	6	* 90360	5/16 Sp Lk Washer
31					80	7	5	*90332	5/16 (NC) Nut
32					81	4	3	*90313	5/16 Plain Washer
33					82				
34					83				
35		1	4921	Saddle Bracket	84	1		90614	1/4 x 1-1/4 (NC) Gr. 5 Cap Screw
36	1		2036	Rear Tank Strap	85	1		90359	1/4 Sp Lk Washer
37	1		2116	Universal Brace Rod	86	1		90330	1/4 (NC) Nut
38					87		1	*90202	7/16 x 5-1/4 (NF) Gr. 5 Cap Screw
39					88		1	*90317	7/16 Flat Washer
40					89		3	*90154	3/8" x 4" (NF) Gr. 5 Cap Screw
41					90		1	*90103	3/8 x 1 (NC) Cap Screw
42	2	1	*A1587	Hose Disconnect Assembly	91		1	*90361	3/8 Lock Washer
43	2	2	*1588	Dust Plug - Closure/Male	92		1	*90334	3/8 (NC) Nut
44		1	* 4486	Adaptor - Bulkhead 1/4" Npt	93		5	*4268	5/8" Spacer Washer
45		3	* 4485	Snap Ring - 7/8" External Bowed	94		1	*90605	M8 x 1.25 x 35 Gr 8.8 Cap Screw
46	1		319	1/4" x 90 Swivel Adapter	95		1	*90428	M8 Lock Washer
47	2		2315	9/16-18 w/O-Ring x 3/8 F Pi Swivel	96		1	*90399	M10 x 1.50 x 100 Gr. 10.9 CS
48					97		1	*90420	M10 Flat Washer
49					98		1	*90429	M10 Lock Washer
					99				

** Order PN 20058 for Drive Sheave w/Bushing for Service

1. Cylinder & Cylinder Hose Assembly

- A. Attach female half of disconnect (42) and a 1/4" Npt 45 degree swivel (60) to 22" Hp Hose (20). Using bench vise to hold lift cylinder (10), remove closure from port and screw the other end of the hose directly into this port. Place lift cylinder with hose pointing to passenger side into ears on lift arm and upper gear. Secure with clevis pins (12) and cotter pins (15).
- B. Attach male half of quick disconnect (42) to one end of a 36" Hp hose (21). Place a dust cover (43) on the end of the other 36" Hp Hose (21) and put another male half of a disconnect (42) on this hose.
- C. Using a bench vise to hold angle cylinders (11), remove closures from ports and screw brass forged street ells (51) into ports. Point forward toward live end of cylinder and slightly upward as they will be installed on the A-Frame. The driver side cylinder uses the 36" Hp hose (21) with the dust cover and male disconnect half. The passenger side uses the 36" Hp hose (21) with the male disconnect end and **no dust cover**. Install cylinders to their respective sides so that ells are between the cylinders and the A-frame. Secure cylinder with anchor pins (13) at both ends, with cotter pins (15) in each anchor.

Note: Dash bracket, hardware, drilling guide and mounting instructions will be found in peculiar attachments box.

2. Control Head & Control Cables

- A. Drill three 5/8" holes in the firewall for the control cables and wiring harness using drilling guide as a reference only. **Be sure both sides of the firewall are clear of obstructions before drilling.** Drill 1/2" hole in underside of dash as shown in dash illustration.
- B. Install the dash bracket as per dash bracket instructions.
- C. Loosen the "jam nuts" on control head end of cables (9) and install into slots in control head (8). (Raise cable centers in beginning of lower slot.) Snap cable ends onto ball studs and tighten jam nuts to secure cables to control head. Remove the nuts and washers from the valve end of the cables. Route the cables out through the firewall up to top of the driver side fender well. Attach control head to dash bracket as per dash bracket instructions. Install rubber grommets (73) around cables where they pass through the fire wall.

3. Valve & Valve Plate

- A. Using a bench vise to hold control valve assembly (2), remove closures from valve ports. Screw the 90 degree swivel adapter unions (47) into the "in" and "out" ports. Screw quill (55) into installed adapter in the "out" port.

Note: Valve fittings are installed as described to insure proper installation. First indication of incorrect installation is failure of plow to lift although plow will angle.

- B. Mount valve to valve plate (29) using two 1/4" x 1-3/4" cap screws, lock washers and nuts located in the valve bag. Install a rubber shock mount (71) into the center and rearmost holes on the driver's side of the valve plate. Fasten each with one 5/16 lock washer (79) and nut (80). Connect control cables to valve plate before fastening valve plate to vehicle. Begin by reinstalling jam nuts and washers on cables. Place control cables in respective slots of valve plate bulkhead with one nut and one washer on each side of bulkhead. Center cables in slots so that they are exactly in line with valve spool centers. Attach cable clevis (3) to cables using square nuts (4). Slip cable clevises over spools. Install clevis pin (5) through clevis and spool and secure with push nut (6) on clevis pin. Temporarily adjust cables so that control lever is somewhere near centered in control head.
- C. Locate valve plate, with valve and cables attached, on top of driver's side inner fender well so that valve is near level and cables run in as smooth as path as possible (be sure swivel adapter does not rub against windshield water bottle). Using the two previously installed shock mounts as guides, mark and drill two 11/32" holes through the fender well. Fasten each shock mount to the fender well with one 5/16 flat washer (81), lock washer (79) and nut (80). Attach 90 degree bent end of valve plate brace (30) to valve plate as shown in illustration with a 5/16 x 1 cap screw (78), lock washer (79) and nut (80). Attach a rubber shock mount (71) to hole in other end of brace with a 5/16 lock washer (79) and nut (80). Using the shock mount as a guide, drill another 11/32" hole through the fender well and fasten shock mount to the fender well with a 5/16 flat washer (81), lock washer (79) and nut (80).

- D. With valve plate fastened to inner fender, re-adjust control cables so that control head lever is centered between both angle and raise/lower positions. If cable clevis does not allow enough adjustment, reposition cable at valve plate bulkhead. After checking to see that the valve spools are in the centered position, tighten cable clevis nuts.

Caution: Valve spools must be free and self centering when cables and control head are attached. Failure to center spools will restrict fluid flow through valve. This may cause hydraulic fluid to overheat resulting in pump damage or hydraulic hose failure. Hose failures can cause engine fires.

When adjusted, the control lever must be in the neutral position to allow enough spool travel each way for proper valve actuation.

4. Drive Sheave Installation

Caution: Before inserting bushing, check center of crankshaft for rust or foreign material and remove.

- A. Remove serpentine belt. Remove and discard three cap screws holding vehicle crank pulley to vibration damper. Remove and discard cap screw and flat washer holding vibration damper to crankshaft, if vehicle is so equipped. Check vehicle crank pulley and remove any burrs around the holes that the cap screws were removed from.
- B. Install drive sheave bushing (28) into center of crank shaft, reinstall vehicle sheave. Place the drive sheave (24) center hub through the vehicle sheave and bushing. Place a 7/16 x 5-1/4 (NF) Gr. 5 cap screw (87) and flat washer (88) in center of sheave, plus three 3/8 x 4 (NF) Gr. 5 cap screws (89) with spacer washers (93) through sheave spacers. Tighten 7/16 x 5-1/4 cap screw (torque to 50 ft-lbs) before tightening the three 3/8 x 4 cap screws (torque to 31 ft-lbs).

5. Pump and Pump Bracket

Caution: Pump tank fill must be vertical to engine.

- A. Remove and save both nuts from front exhaust manifold port. Remove and discard the two cap screws attaching alternator to alternator support bracket. Place both slots onto manifold studs and attach with previously removed nuts. **Do not fully tighten any fasteners until all fasteners and pump bracket brace are installed.** Align slotted tab on pump bracket with outboard hole in alternator and attach threaded hole in alternator support bracket with one M10 x 1.5 x 100 Gr. 10.9 cap screw (96), M10 lock washers (98) and M10 flat washer (97). Fasten pump bracket brace (27) to remaining hole in alternator bracket and alternator with one M8 x 1.25 x 35 Gr. 8.8 cap screw (94), M8 lock washer (95), and two spacer washers (93) between brace and alternator. **Cropped out portion of pump bracket brace should be positioned towards alternator cooling fins.** Attach other end of brace to lower hole in pump bracket with one 5/16 x 1 Gr. 5 (NC) cap screw (78), lock washer (79) and (NC) nut (80). Tighten all pump bracket fasteners. Using remaining hole in bent portion of pump bracket as guide, drill a 13/32" hole through alternator bracket and fasten brackets together with a 3/8 x 1 (NC) Gr. 5 cap screw (90), lock washer (91) and (NC) nut (92).
- B. Holding pump tank (1) in bench vise, screw 1/4" brass bar elbow (52) onto pressure port and 3/8" brass bar street ell (53) with quill (55) into return port. These fittings should turn slightly outward (approximately 10 o'clock) while looking at rear of pump tank. Install pump sheave (25) onto pump shaft using lock nut and key supplied with pump. Remove pump from vise and install saddle bracket (35) on over front of pump. Secure with a 5/16 x 1-1/2 Gr. 5 cap screw (77), lock washer (79) and nuts (80). Attach saddle bracket and pump to pump bracket using two 5/16 x 1 cap screws (78), flat washers (81), lock washers (79) and nuts (80).
- C. Reinstall serpentine belt. Install 61" V-belt (23) on over installed drive and pump sheaves. Align sheaves and tighten 1-1/2" saddle bracket fastener. Adjust for proper tension by pivoting saddle bracket on top bolt.

Caution: Position power steering hoses so there is at least 1-1/2 clearance from the pump "V" belt

Install rear tank strap (36) on over rear of pump. Install one 5/16 nut (80) and 5/16 flat washer (81) onto universal brace rod (37). Install bent end of brace rod between ears of tank strap while inserting other end through hole in remaining tab on pump bracket. Cut universal brace rod to proper length. Fasten brace rod top ears of tank strap with a 1/4 x 1-1/4 cap screw (84), lock washer (85) and nut (86). Fasten other end of brace rod to tab with a 5/16 flat washer (81), 5/16 lock washer (79) and nut (80). Use brace rod to adjust alignment of drive and pump sheaves. Check belt for proper tension. Tighten power steering and alternator belts.

6. Hydraulic Hose Installation

- A. Attach 26" HP hose (16) to 1/4" brass bar elbow on pump tank and push 26" LP hose (17) onto quill on pump tank. Route these hoses to the control valve. Cut 26" hose to proper length.

Caution: Keep hoses away from hot or moving engine components. Failure to do so may cause hose to burst resulting in a possible fire.

Push LP hose onto quill and screw HP hose into 90 degree swivel adapter. Drill an 1-7/8" hole in the radiator core support just outboard of the radiator on the driver's side, about 9-1/2" down from the top. Install a split hose grommet (74) around the hole. **Some vehicle with extra heavy duty cooling may require hoses to be passed out through core support near driver's side headlight.** Install the O-ring end of the 42" angle hose (18) to the rear angle port of the valve. Pass it out through the core support and through the grille low and about 14" off center on the driver's side. Attach female half of QD to the QD/electric grille plate (56) with a snap ring (45). Put a dust plug (43) on the angle hose and tighten into the QD.

Note: On trucks with extra heavy duty cooling, a 1/4 NPT 45 degree swivel (60) may be used in the back of QD to accommodate the re-routed hose. Slide the headlight connector (with dust cover) in the slot provided. Some GMC models with a fine mesh grille may have to use two standoff legs (58) fastened with four 1/4 x 1/2 socket head cap screws (61) and lock nuts (62) on each grille plate. The grille plate should be oriented with headlight connector to the inside.

- B. Install the O-ring end of a 66" angle hose (19) to the front angle port of the valve. Pass it out through core support and route it out through the grille low and about 14" off center on passenger side. Attach a female half of a QD to one hole in the 2 QD grille plate (57) with snap ring (45). Attach a bulkhead adaptor (44) with snap ring (45) to the other hole in plate. Attach a male half of a QD to this adaptor.

Note: For GMC's with fine mesh grill, no further adapters are needed. The hoses may be installed directly to the back of the QD's after sliding dust plugs over the hose fittings. Install the standoff legs after hoses are tightened.

On trucks without standoffs, attach a 1/4 NPT 90 degree swivel (46) and dust cover to the female disconnect half which will be the outside fitting when the plate is attached to the grille. Tighten the already installed angle head to the 90 degree swivel. Install the O-ring end of the other 66" hose to the raise port of the valve. Pass it out through the grille on the passenger side into the same opening as the already installed angle hose. On trucks without grille plate standoffs attach a 1/4 NPT 45 degree swivel and a dust plug to the rear of the male QD half. On grilles with standoff legs, the 45 degree fitting is not necessary. Attach plate with two long tie wraps (59). (Vehicle with heavy duty cooling and air conditioning will need the 3" fitting protector (76) on hoses rubbing edge of coils between radiator and grille. Attach fitting protector with tie wrap (75).)

- C. Install cable boot bracket (65) on drivers' side headgear brace, between brace and fasteners. Insert cable boot (66) on over bracket.
- D. Install the in-line oil filter (7) as per instructions located in the common hydraulics kit.

7. Operations

- A. Check all fittings and fasteners for tightness. Secure hoses with nylon tie wraps (75). Be sure hoses clear battery post. Place caution label (72) on the dash beside the control head.
- B. Fill reservoir with type "A" automatic transmission fluid. Start the engine, lift and angle the blade. **If the blade angles opposite from the control lever position, reverse the two Hp hose connections on valve.** Raise the front end of the vehicle until the plow is clear of the ground with the lift cylinder fully retracted. Check the reservoir oil level. Angle the blade (with the lift cylinder retracted) to remove air from the system. Recheck the reservoir oil level.

Note: The installer must inform the end user of the proper procedure for removing any residual hydraulic pressure that may be trapped in the raise or angle hoses. The plow will be much easier to install or remove if the proper procedures are followed. Before coupling or uncoupling the hydraulic disconnects you must first turn off the ignition. Move the control to all four plowing positions and return the control to lower. You may then remove or install the plow.