

31303

MOUNT KIT PERSONAL PLOW

Nissan Titan

2004 - 09

Installation Instructions

⚠ CAUTION

Read this document before installing the snowplow.

⚠ CAUTION

See your sales outlet/Web site for specific vehicle application recommendations before installation. The Kit Selection Guide/Selection List has specific vehicle and snowplow requirements.

SAFETY DEFINITIONS

⚠ WARNING
 Indicates a potentially hazardous situation that, if not avoided, could result in death or serious personal injury.

⚠ CAUTION
 Indicates a potentially hazardous situation that, if not avoided, may result in minor or moderate injury. It may also be used to alert against unsafe practices.

NOTE: Indicates a situation or action that can lead to damage to your snowplow and vehicle or other property. Other useful information can also be described.

WARNING/CAUTION & INSTRUCTION LABELS

Become familiar with and inform users about the warning/caution labels on the back of the blade and the instruction label on the headgear.

NOTE: If labels are missing or cannot be read, see your sales outlet.

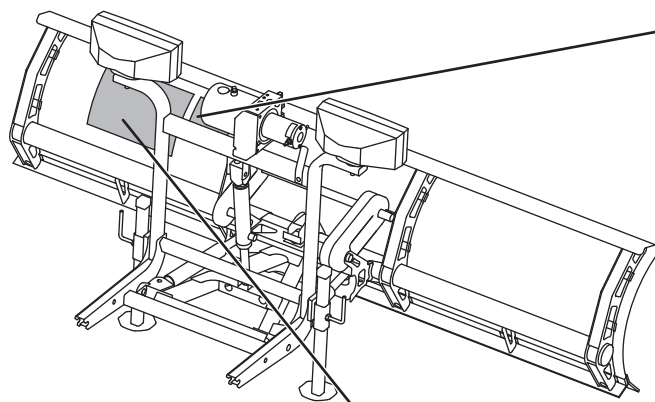

Warning and Caution Label

⚠ WARNING

LOWER BLADE WHEN VEHICLE IS PARKED.
 DO NOT EXCEED GVWR OR GAWR INCLUDING BLADE AND BALLAST.
 REMOVE BLADE ASSEMBLY BEFORE PLACING VEHICLE ON HOIST.

⚠ CAUTION

READ *OWNER'S MANUAL* BEFORE OPERATING OR SERVICING SNOWPLOW.
 TRANSPORT SPEED SHOULD NOT EXCEED 45 MPH. FURTHER REDUCE SPEED UNDER ADVERSE TRAVEL CONDITIONS.
 PLOWING SPEED SHOULD NOT EXCEED 10 MPH.
 SEE YOUR SALES OUTLET/WEB SITE FOR SPECIFIC VEHICLE APPLICATION RECOMMENDATIONS.

Instruction Label

This snowplow is for personal/homeowner use only.

ATTACH INSTRUCTIONS

1. Make certain both **connecting pins** are fully retracted.
2. Drive vehicle slowly to completely insert **attachment arms** into **receiver assembly** slots.

3. Twist both **connecting pins** to release spring tension, then push **plow gear** toward vehicle so **connecting pins** fully engage holes in **attachment arms**.

4. Loosen one **jack handle** and slide **jack sleeve** down below **jack retainer**. Remove **jack** and retighten **jack handle**. Repeat for other **jack** and store them.
5. Connect all electrical cables from vehicle to snowplow.

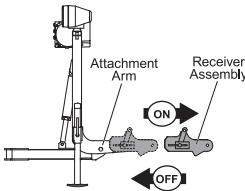
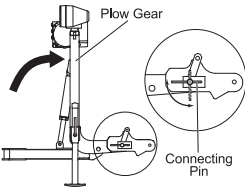
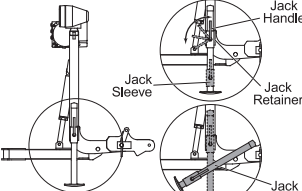
U.S. patents 5,420,480; 6,253,470; 6,941,685; 7,400,058; RE35,700; CAN patent 2,060,425; and other patents pending.

5. Back vehicle away from snowplow.
6. See Owner's Manual for proper snowplow storage.

3. While pushing **plow gear** toward vehicle to release **connecting pin** tension, pull **connecting pin** out on one side and twist pin handle to keep pin retracted. Repeat procedure for other **connecting pin**.
4. Disconnect all electrical cables.

1. Put blade on ground using **LOWER/FLOAT** on snowplow control. Leave control **ON** and in **FLOAT**.
2. Attach **jacks**. Loosen **jack handle**, put **jack** on ground, and raise **jack sleeve** until fully engaging **jack retainer**. Tighten **jack handle**. Repeat for other **jack**.

DETACH INSTRUCTIONS

Read Owner's Manual for complete instructions.

SAFETY PRECAUTIONS

Improper installation and operation could cause personal injury and/or equipment and property damage. Read and understand labels and the Owner's Manual before installing, operating or making adjustments.

⚠ WARNING

Lower the blade when vehicle is parked. Temperature changes could change hydraulic pressure, causing the blade to drop unexpectedly or damaging hydraulic components. Failure to do this could result in serious personal injury.

⚠ WARNING

The driver shall keep bystanders clear of the blade when it is being raised, lowered or angled. Do not stand between the vehicle and the blade or within 8 feet of a moving blade. A moving or falling blade could cause personal injury.

⚠ WARNING

Keep hands and feet clear of the blade and A-frame when mounting or removing the snowplow. Moving or falling assemblies could cause personal injury.

⚠ WARNING

Do not exceed GVWR or GAWR including the blade and ballast. The rating label is found on the driver-side vehicle door cornerpost.

⚠ WARNING

To prevent accidental movement of the blade, always turn the control OFF whenever the snowplow is not in use. The power indicator light will turn OFF.

⚠ WARNING

Remove the blade assembly before placing vehicle on hoist.

⚠ CAUTION

Refer to the Kit Selection Guide/Selection List for minimum vehicle recommendations and ballast requirements.

PERSONAL SAFETY

- Remove ignition key and put the vehicle in park or in gear to prevent others from starting the vehicle during installation or service.
- Wear only snug-fitting clothing while working on your vehicle or snowplow.
- Do not wear jewelry or a necktie, and secure long hair.
- Wear safety goggles to protect your eyes from battery acid, gasoline, dirt and dust.
- Avoid touching hot surfaces such as the engine, radiator, hoses and exhaust pipes.
- Always have a fire extinguisher rated BC handy, for flammable liquids and electrical fires.

FIRE AND EXPLOSION

⚠ WARNING

Gasoline is highly flammable and gasoline vapor is explosive. Never smoke while working on vehicle. Keep all open flames away from gasoline tank and lines. Wipe up any spilled gasoline immediately.

Be careful when using gasoline. Do not use gasoline to clean parts. Store only in approved containers away from sources of heat or flame.

CELL PHONES

A driver's first responsibility is the safe operation of the vehicle. The most important thing you can do to prevent a crash is to avoid distractions and pay attention to the road. Wait until it is safe to operate Mobile Communication Equipment such as cell phones or two-way radios.

VENTILATION



⚠ WARNING

Vehicle exhaust contains lethal fumes. Breathing these fumes, even in low concentrations, can cause death. Never operate a vehicle in an enclosed area without venting exhaust to the outside.

TORQUE CHART

⚠ CAUTION

Read instructions before assembling. Fasteners should be finger tight until instructed to tighten according to the torque chart. Use standard methods and practices when attaching snowplow, including proper personal protective safety equipment.

Recommended Fastener Torque Chart (ft-lb)			
Size	Torque		
	 SAE Grade 2	 SAE Grade 5	 SAE Grade 8
1/4-20	6	9	13
5/16-18	11	18	28
3/8-16	19	31	46
3/8-24	24	46	68
7/16-14	30	50	75
1/2-13	45	75	115
9/16-12	66	110	165
5/8-11	93	150	225
3/4-10	150	250	370
7/8-9	150	378	591
1-8	220	583	893
Metric Grade 8.8 (ft-lb)			
Size	Torque	Size	Torque
M 6	7	M 12	60
M 8	17	M 14	95
M 10	35	M 16	155
These torque values apply to fasteners except those noted in the instruction.			

INSTALLATION INSTRUCTIONS

NOTE: For easier assembly and installation, vehicle and all snowplow components should be on a smooth, level, hard surface, such as concrete.

Mount Installation

1. If the vehicle is equipped with a stamped-steel splash guard and/or tow hooks, remove them. Retain the splash guard, tow hooks, and fasteners for reinstallation if the snowplow mount is removed.

If the vehicle is equipped with a front skid plate, remove it and the adjoining support brackets and tow hooks. Retain the skid plate, support brackets, tow hooks, and fasteners for reinstallation if the snowplow mount is removed. Remove the license plate and connecting bracket assembly from the skid plate and reinstall it to the vehicle's front bumper as located by the preexisting detents.

2. Position the mount against the bottom surfaces of the vehicle frame rails while aligning the front mount holes with the tow hook holes. Secure the mount to the frame rails with M12 x 40mm cap screws and 1/2" washers (supplied with the mount). Hand tighten only.
3. Clamp the rear of the mount against the bottom surfaces of the vehicle frame rails on both the driver and passenger sides.
4. Remove the bumper brace to gain access for drilling holes through the vehicle frame rails. Using the rear hole in the mount as a guide, drill a 17/32" hole through the outside wall of the vehicle frame rail.

- Place a 1/2" washer onto a 1/2" cap screw with handle, and insert the cap screw into the slot located on the bottom surface of the vehicle frame rail rearward of the mount. Pass the cap screw out through the vehicle frame and mount holes, bending the handle as necessary. Place a 1/2" locknut on the cap screw and hand tighten.

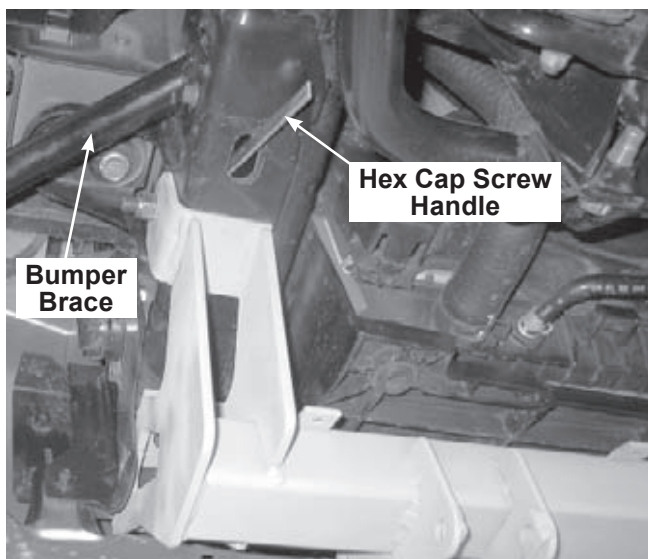

- Repeat Steps 5 and 6 on the opposite side of the vehicle.
- Tighten all fasteners according to the torque chart.
- Bend or cut the ends of the cap screw handles protruding out from the truck frame.
- Reinstall the bumper braces on both sides of the vehicle.

NOTE: After five to ten hours of snowplow usage, retorque all mount assembly fasteners.

- Install the rubber splash shield as instructed at right.

Splash Shield Installation

- Lay the rubber material on a flat surface. Drill four holes in the trimmed rubber splash shield according to the layout illustrated below.

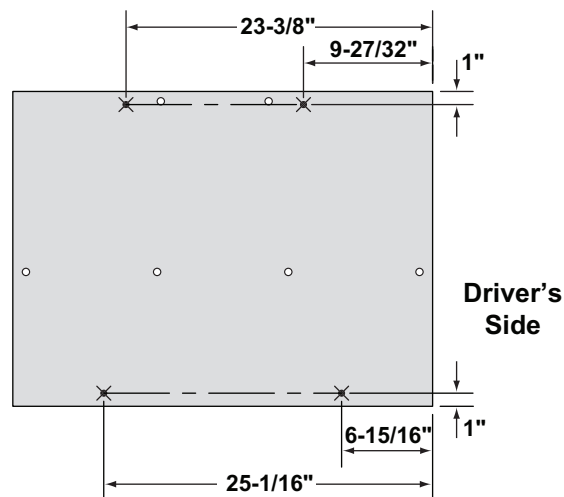

× = Measure and drill 5/16" holes (4 places).

○ = 5/16" holes (6 places) to be drilled during installation, using mount and vehicle frame as guides.

- Cut the material as shown below.

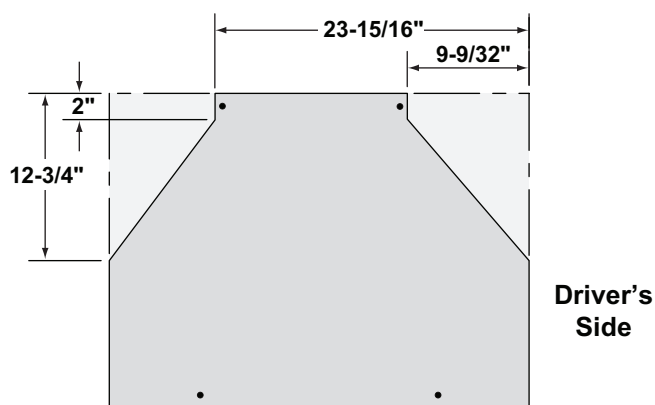

- Position the splash shield on the vehicle so that the tapered end is toward the rear and the shield is on top of the mount and below the vehicle sway bar.

4. **If the vehicle is equipped with a transaxle skid plate**, remove the two front skid plate bolts. Position the tapered end of the splash shield between the skid plate and the vehicle frame cross member. Install two M6 x 25mm cap screws and washers (supplied with the mount) through the holes drilled in Step 1 and into the cross member. Do not overtighten. Using the holes in the skid plate as guides, drill two 5/16" holes in the splash shield. Reinstall the two skid plate bolts through the skid plate and splash shield.

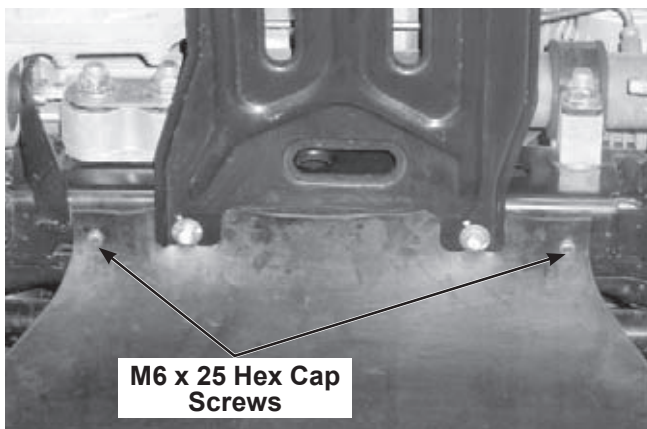

If the vehicle is not equipped with a transaxle skid plate, align the holes in the rear splash shield retainer and the tapered end of the splash shield with those in the vehicle frame cross member. Install two M6 x 25mm cap screws and washers (supplied with the mount) through the rear splash shield retainer and splash shield and into the cross member. Do not overtighten.

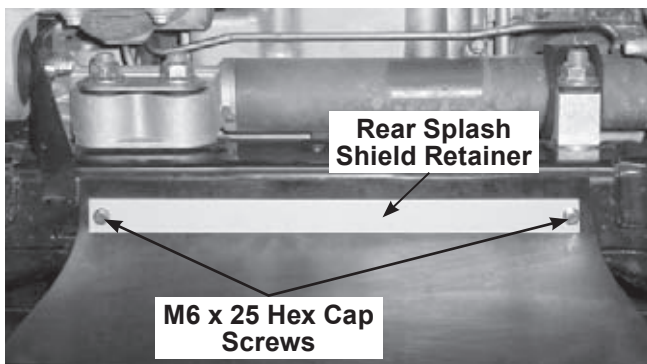

5. Make sure the splash shield is under the vehicle sway bar, then pull the uncut end of the shield to the vehicle bumper support beam.
6. Attach the front of the splash shield to the angled surface of the vehicle bumper support beam using the front splash shield retainer and two M6 x 25mm cap screws and washers (supplied with the mount).

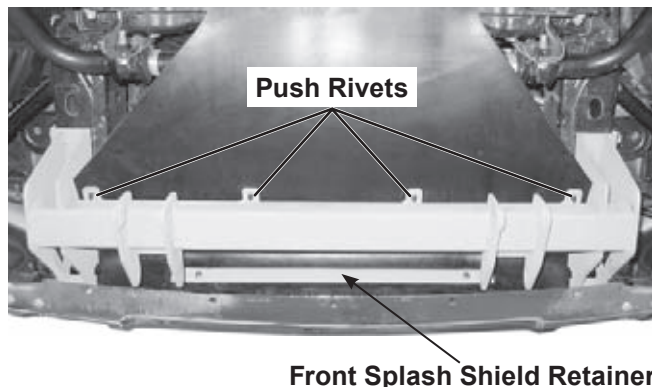

7. If the bumper fascia has extensions that attached to the stamped-steel splash guard or skid plate, use those bolt holes as guides and drill two 5/16" holes in the splash shield. Attach the splash shield to the bumper extensions by inserting two plastic push rivets down through the shield holes and into the bumper extension holes.
8. Using the holes in the tabs at the rear of the mount center tube as guides, drill four 5/16" holes in the splash shield. Attach the center of the splash shield to the mount center tube by inserting four plastic push rivets down through the shield holes and into the tab holes.

The company reserves the right under its product improvement policy to change construction or design details and furnish equipment when so altered without reference to illustrations or specifications used. This equipment manufacturer or the vehicle manufacturer may require or recommend optional equipment for snow removal. Do not exceed vehicle ratings with a snowplow. The company offers a limited warranty for all snowplows and accessories. See separately printed page for this important information.

Printed in U.S.A.