

License Plate Light Kit

0.35 yd³ & 0.7 yd³ Stainless Steel Hopper Spreaders

PARTS LIST

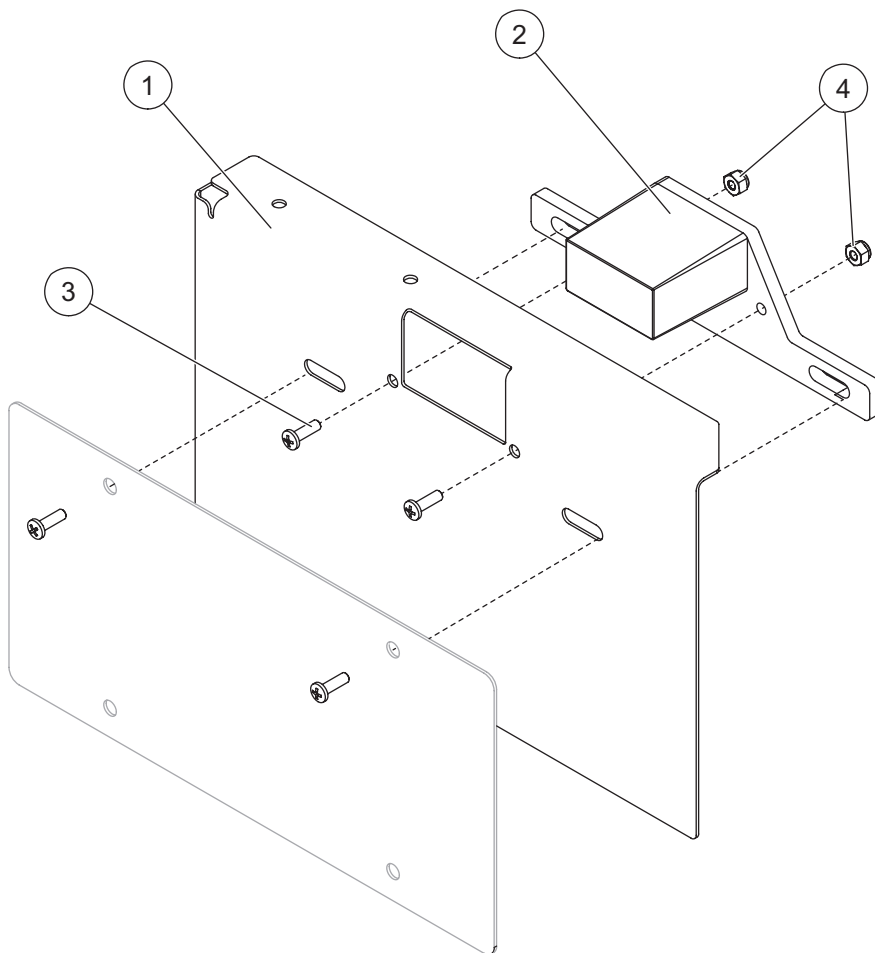

85694 License Plate Light Kit							
Item	Part	Qty	Description	Item	Part	Qty	Description
1	96610	1	License Plate Bracket	ns	92060	1	Bolt Bag
2	68298	1	Plate Light Service Kit				
92060 Bolt Bag							
3		2	#10-32 x 5/8 Machine Screw SS	ns		2	3/8-16 Hex Locknut GB SS
4		2	#10-32 Locknut SS	ns		1	1/4 Insulated Receptacle 16-14 ga
ns		2	3/8-16 x 1 Carriage Bolt	ns		1	1/4 Insulated Blade 16-14 ga
ns		2	3/8 Flat Washer Type A Wide SS				
ns = not shown				SS = Stainless Steel			

INSTALLATION INSTRUCTIONS

⚠ CAUTION

Read this document before installing the license plate light kit.

⚠ CAUTION

Use standard methods and practices when attaching spreader and installing accessories, including proper personal protective safety equipment.

Park the vehicle on a smooth, level, hard surface, such as concrete. Turn the vehicle ignition OFF and remove the key.

- Using the two #10 x 5/8" screws and #10 locknuts, fasten the license plate light to the steel license plate bracket.

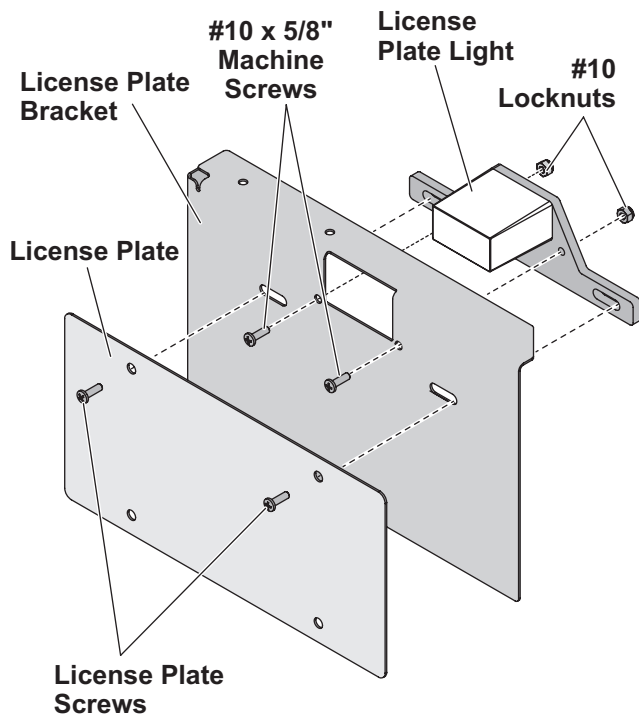

- Using the two license plate screws, attach the license plate to the bracket and plate light.

- On the passenger's side of the spreader, locate the 3/8" or 1/2" hardware (depending on the spreader model) that matches the hole pattern on the license plate bracket assembly.
- Remove the nuts and washers, install the bracket, and reinstall the hardware.

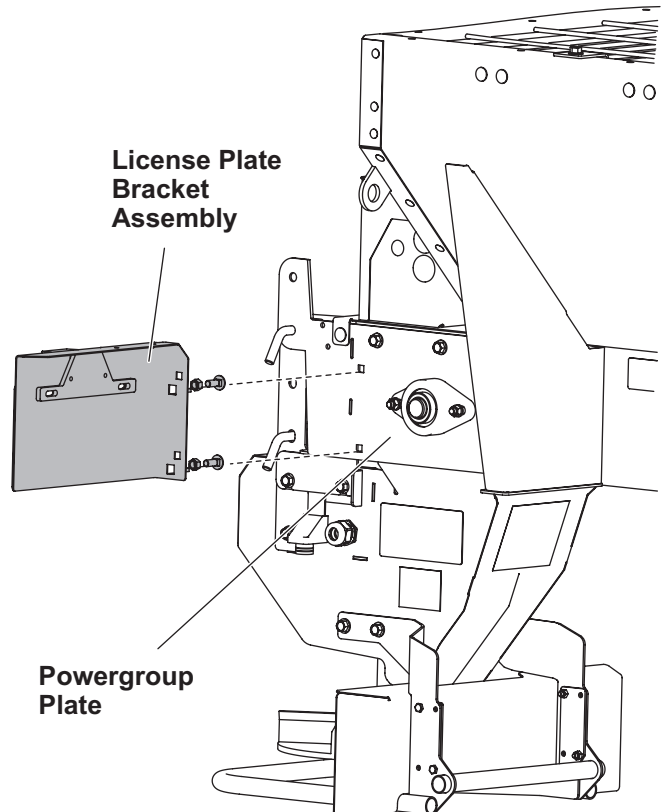

Install the Harness

Route the license plate lamp electrical lead through a grommet on the electrical box.

Electrical Connections—Hopper-Side

1. Remove the electrical box cover.
2. Locate the 2-pin connector (brown and black wire) on the spinner harness. Unplug the connector from main harness and cut the brown wire 2" back from the connector. Strip the insulation so that approximately 1/4" of wire is exposed on the plug side only.
3. Locate the black and white leads from the license plate lamp. Strip the insulation so that approximately 1/4" of wire is exposed.
4. Crimp the supplied ring terminal to the black wire and cover it with heat shrink tubing.
5. Crimp the white wire from the plate light to the brown wire on the spinner harness using the supplied butt connector.
6. Connect the ring terminal to the NEGATIVE (-) side of the isolation block.
7. Reconnect the 2-pin connector of the spinner harness to the main harness.

Electrical Connections—Vehicle-Side

1. Locate a spot on the vehicle harness assembly approximately 20" up from the main molded connector.
2. At this spot open the convoluted tubing that covers the cable assembly and pull out the brown wire.
3. Splice this brown wire to the vehicle license plate lamp or park lamp circuit.

Copyright © 2023 Douglas Dynamics, LLC. All rights reserved. This material may not be reproduced or copied, in whole or in part, in any printed, mechanical, electronic, film or other distribution and storage media, without the written consent of the company. Authorization to photocopy items for internal or personal use by the company's outlets or spreader owner is granted.

The company reserves the right under its product improvement policy to change construction or design details and furnish equipment when so altered without reference to illustrations or specifications used. This equipment manufacturer or the vehicle manufacturer may require or recommend optional equipment for spreaders. Do not exceed vehicle ratings with a spreader. The company offers a limited warranty for all spreaders and accessories. See separately printed page for this important information.

Printed in U.S.A.
