



**Fisher Engineering**

50 Gordon Drive, Rockland, Maine 04841-2139 • www.fisherplows.com

**RB400, 74980**

April 15, 2017  
Lit. No. 76638, Rev. 00

# Rotary Broom

## Owner's Manual *Original Instructions*

**⚠ CAUTION**

**Read this document before operating or  
servicing the rotary broom.**

This document is for FISHER® RB400 rotary brooms with  
serial numbers beginning with 170301 and higher.

---

**This document supersedes all editions with an earlier date.**



# TABLE OF CONTENTS

---

|  |    |
|--|----|
| <b>PREFACE</b> .....                           | 4  |
| Owner's Information.....                       | 4  |
| <b>SAFETY INFORMATION</b> .....                | 5  |
| <b>OPERATING INSTRUCTIONS</b> .....            | 7  |
| Component Vocabulary.....                      | 7  |
| General Safety.....                            | 8  |
| Operating in Winter.....                       | 8  |
| Operator Controls.....                         | 9  |
| Starting/Stopping Motor.....                   | 11 |
| Adjusting Handlebar Height.....                | 13 |
| Transport.....                                 | 13 |
| Adjusting Ejection Direction.....              | 14 |
| Adjusting Brush Pressure.....                  | 15 |
| Plow Blade.....                                | 16 |
| Debris Collector Box (Optional Accessory)..... | 17 |
| <b>MAINTENANCE</b> .....                       | 18 |
| Oil and Gas.....                               | 18 |
| Tire Pressure.....                             | 19 |
| Adjusting Control Cables.....                  | 20 |
| Replacing/Changing Brushes.....                | 21 |
| Maintenance Plan.....                          | 22 |
| Cleaning.....                                  | 22 |
| <b>TROUBLESHOOTING</b> .....                   | 23 |

## PREFACE

---

This manual has been prepared to acquaint you with the safety information, operation and maintenance of your new rotary broom. Please read this manual carefully and follow all recommendations. This will help ensure profitable and trouble-free operation of your rotary broom. Keep this manual accessible. It is a handy reference in case minor service is required.

When service is necessary, bring your rotary broom to your distributor. They know your rotary broom best and are interested in your complete satisfaction.

**Register your rotary broom online at [www.fisherplows.com](http://www.fisherplows.com)**

### OWNER'S INFORMATION

Owner's Name: \_\_\_\_\_

Date Purchased: \_\_\_\_\_

Outlet Name: \_\_\_\_\_ Phone: \_\_\_\_\_

Outlet Address: \_\_\_\_\_

Engine Model: \_\_\_\_\_ Weight: \_\_\_\_\_ lb/kg

Rotary Broom Serial #: \_\_\_\_\_ Engine Serial #: \_\_\_\_\_

NOTE: Some photos in this manual show the rotary broom with the optional Multi-Purpose Brush Kit (PN 72258).

# SAFETY

## SAFETY DEFINITIONS

### **⚠ WARNING**

Indicates a potentially hazardous situation that, if not avoided, could result in death or serious personal injury.

### **⚠ CAUTION**

Indicates a potentially hazardous situation that, if not avoided, may result in minor or moderate injury. It may also be used to alert against unsafe practices.

**NOTE:** Indicates a situation or action that can lead to damage to your rotary broom or other property. Other useful information can also be described.

## LABELS

Please become familiar with the labels on the rotary broom.

**NOTE:** If labels are missing or cannot be read, see your sales outlet.

| Code  | Definition                |
|-------|---------------------------|
| YY    | 2-Digit Year              |
| MM    | 2-Digit Month             |
| DD    | 2-Digit Day               |
| LL    | 2-Digit Location Code     |
| ####  | 4-Digit Sequential Number |
| 74980 | Part Number               |

### Serial Number Label

Engine: Honda GXV160  
HP: 4.3  
Weight: 238 lbs

Manuf. 2017



Model: RB400

Serial No. 17030120123474980



## DANGER ZONE

Keep all bystanders away from the machine at least 30 feet (10 meters), as depicted in the diagram below.

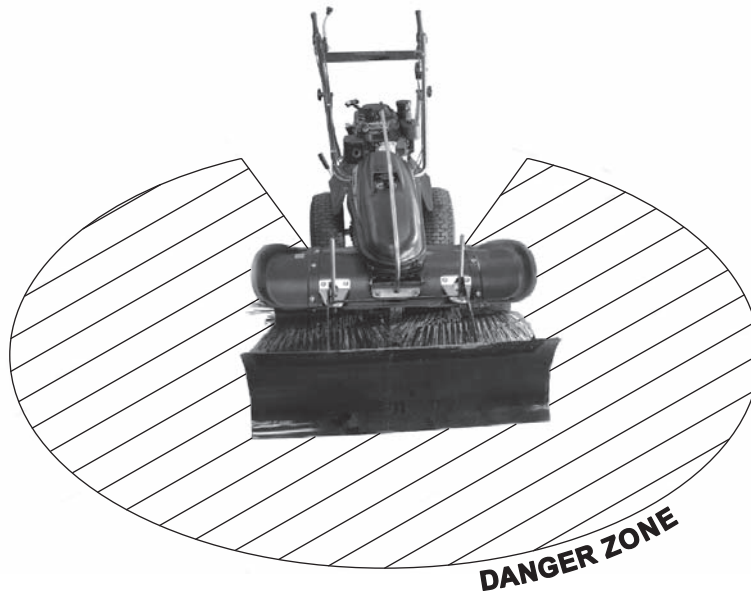

# SAFETY

## SAFETY PRECAUTIONS

Improper assembly and operation could cause personal injury and/or equipment and property damage. Read and understand labels and this Owner's Manual before assembling, operating or making adjustments.

The machine is intended exclusively for use for brushing operations in property maintenance and snow clearance. Examples of intended use are: snow clearing; sidewalk, driveway and parking lot cleaning (with multi-purpose brushes); spring debris clean-up; dethatching; clearing debris from artificial turf; and leaf clean-up (with multi-purpose brushes).

### WARNING

- Always make sure personnel are clear of areas of danger when using equipment.
- Before working with the rotary broom, secure all loose-fitting clothing and unrestrained hair.
- Do not climb onto or ride on rotary broom.

### CAUTION

- Do not operate a rotary broom in need of maintenance.
- Before operating the rotary broom, reassemble any parts or hardware removed for cleaning or adjusting.
- Before operating the rotary broom, remove materials such as cleaning rags, brushes, and hand tools from the rotary broom.
- Tighten all fasteners according to the Torque Chart. Refer to Torque Chart for the recommended torque values.

**NOTE:** Lubricate grease fittings after each use. Use a good quality multipurpose grease.

## PERSONAL SAFETY

- Wear only snug-fitting clothing while working on your rotary broom.
- Do not wear jewelry or a necktie, and secure long hair.
- Wear safety goggles to protect your eyes from dirt, dust and flying debris.
- Be aware of and avoid pinch points when assembling and operating. Pinch points can exist around levers and when putting two parts together (during assembly).

## FIRE AND EXPLOSION

### WARNING

Gasoline is highly flammable and gasoline vapor is explosive. Never smoke while working on vehicle. Keep all open flames away from gasoline tank and lines. Wipe up any spilled gasoline immediately.

## VENTILATION

### WARNING

Engine exhaust contains lethal fumes. Breathing these fumes, even in low concentrations, can cause death. Never operate an engine in an enclosed area without venting exhaust to the outside.

## NOISE

Airborne noise emission during use is below 70 dB(A) for the rotary broom operator.

## VIBRATION

Operating rotary broom vibration does not exceed 2.5 m/s<sup>2</sup> to the hand-arm or 0.5 m/s<sup>2</sup> to the whole body.

# OPERATING INSTRUCTIONS

## COMPONENT VOCABULARY

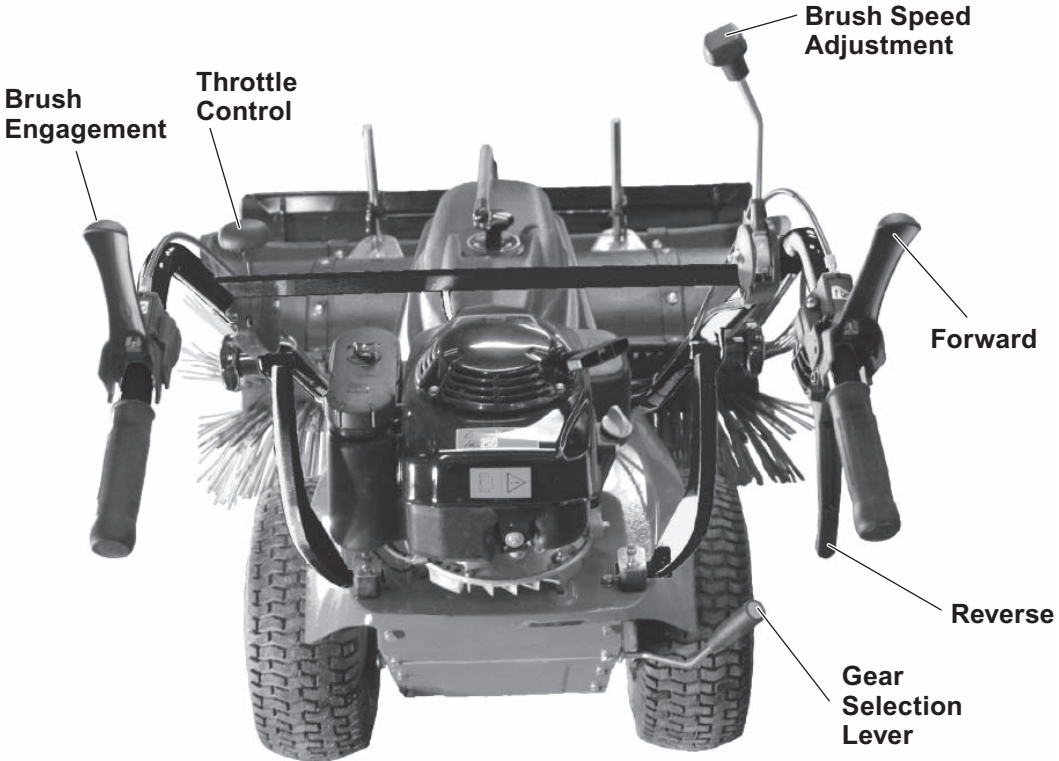
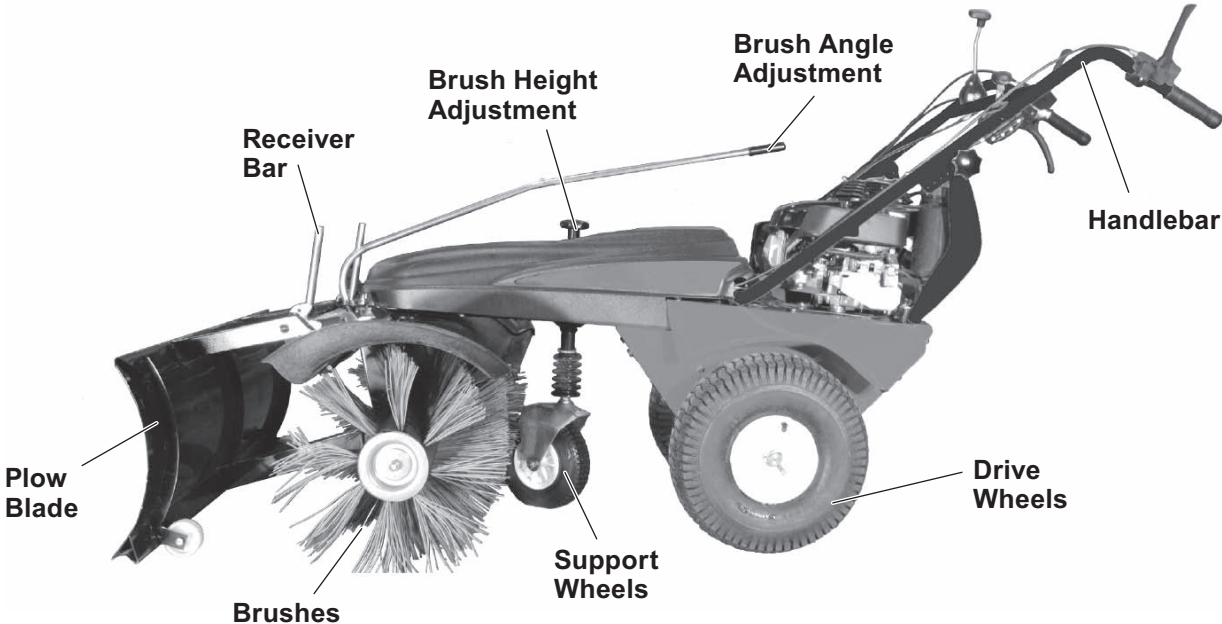

# GENERAL SAFETY/OPERATING IN WINTER

---

## GENERAL SAFETY

Do not operate the machine in an unsafe manner. Make yourself familiar with the surroundings before starting work in a new location. The working surroundings include any obstacles in the work area or on roads, the ground load-bearing capacity and any necessary workplace safety precautions in live traffic.

Take precautions to ensure that the machine is only operated in a safe and functional condition. Only operate the machine if all protective and safety devices are present and working.

Check the machine for externally visible damage and faults before operation. If malfunctions occur stop the machine and secure it immediately. Repair malfunctions immediately. Only start the machine from the operator's position. Ensure that no one can be endangered by starting the machine before switching it on or operating it.

Check that braking, steering, and brushing are fully functional before operation.

Before operating the machine, always check that accessories are fitted correctly. Always observe applicable traffic regulations before operating on public roads, paths or parks, and ensure that the machine is in a condition suitable for use in traffic.

Always ensure that suitable lighting is available before working in poor light or darkness. Always keep a sufficient distance between the machine and drop-offs, holes, or slopes.

Do not permit any method of working which will affect the stability of the machine.

Never traverse across slopes; always travel up and down, not across.

Adjust the speed to suit the conditions on inclines. Change gear before the incline, not on it. Always secure the machine against rolling away and unauthorized operation before leaving it unattended.

## OPERATING IN WINTER

Check regularly that the air filter is dry. If the air filter has become wet, let it dry overnight. There is a possibility of the engine not starting due to a clogged air filter.

Spray the throttle cable with silicone spray at both ends, and the throttle linkage before operating to prevent the cable or throttle mechanism from freezing up.

Before putting the machine away, sweep it clear of snow.

Avoid freezing the machine. Store the machine in a frost-free room.

Silicone spray attracts dust and binds it to the machine. It is only a suitable lubricant in wintry and snowy conditions.

Do not spray silicone spray on hot engine. It could cause a fire. Follow the instructions on the spray can.



# OPERATING INSTRUCTIONS

## OPERATOR CONTROLS

### **⚠ WARNING**

The handlebar can get stuck inside long sleeves. This could prevent the drive from disengaging and result in injury. Set the bar lower if wearing long sleeves or tightly button the sleeves.

### **⚠ WARNING**

Avoid injury and damage; Make completely sure that there are no persons or objects within the danger zone.

### **⚠ CAUTION**

If the brushes are switched ON and the rotary broom is not in gear, the machine can roll backwards. The handlebar must be securely engaged at the required height.

## DRIVING AND SWEEPING

Sweeping and driving can be engaged independent of each other. Having the brush engaged without the transmission engaged will cause the machine to roll backward. The brush can be engaged and disengaged as necessary while driving.

The brush speed can be adjusted to your preference. Pushing the lever forward will increase the speed; pulling back will decrease the brush speed. If the brush starts to leave debris behind, increase the rotation speed (see Adjusting Brush Speed) and select a lower gear (see Selecting a Gear).

The rotary broom is also equipped with a reverse gear. Come to a complete stop before engaging the reverse gear. Ensure the area behind is clear before backing up. Do not operate brush in reverse.

## HANDLEBAR CONTROLS

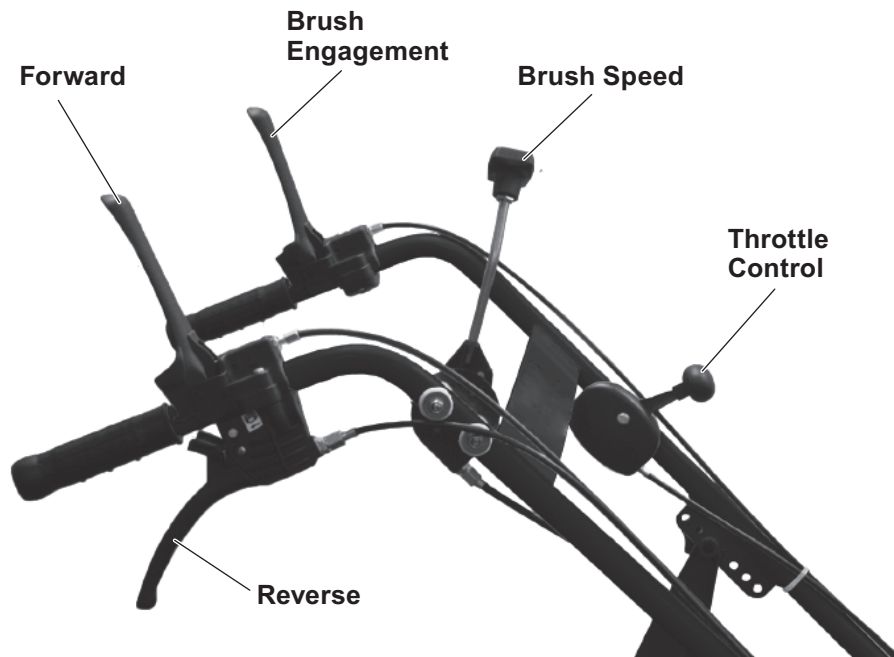

# OPERATING INSTRUCTIONS

## SELECTING A GEAR

Come to a complete stop before changing gears.

The rotary broom is equipped with a 3-speed transmission:

- **1st gear** is the slowest setting and is engaged by pulling the shift lever all the way back.
- **3rd gear** is the fastest setting and is engaged by pushing the lever all the way forward.
- **2nd gear** is in the middle.

You will feel the lever lock into a detent and hear a "click".



**Gear Lever Location**



**Freewheel**



**Locked**

## FREEWHEEL

There is a freewheel mechanism on each wheel. The freewheel makes turning the machine easier. One or both wheels can be locked for working on inclines and when clearing snow.

The freewheel is disabled by putting the linchpin through both wheel and axle, locking the two together.

When removing snow with the plow, locking the wheel on the windrow-side will reduce the lateral force on the handlebars.

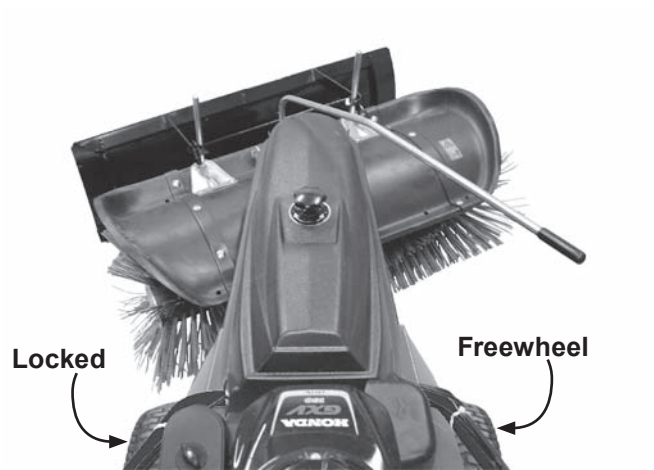

**Plowing**

# OPERATING INSTRUCTIONS

---

## ADJUSTING BRUSH SPEED

The speed of the brushes can be increased using the lever on the right handlebar. The brush speed must only be adjusted when the brush is switched on.

When sweeping dust, use a low brush speed.

When sweeping leaves or similar material, use a high brush speed.

When sweeping snow, use a high brush speed.

When using the debris collector box, use a medium brush speed.

**Remember that an increased brush speed will throw debris farther, therefore increasing the danger zone.**

## STARTING/STOPPING MOTOR

### **⚠ WARNING**

**Engine exhaust contains lethal fumes. Breathing these fumes, even in low concentrations, can cause death. Never operate an engine in an enclosed area without venting exhaust to the outside.**

### **⚠ CAUTION**

**Ensure that the transmission and brush are switched OFF before starting. The handlebar must be secure at the required height.**

**NOTE:** Before starting the motor, ensure there is sufficient oil. The motor is not filled with oil when the machine is delivered.

## Starting the Motor

Move throttle control to the choke position. Adjust choke.



# OPERATING INSTRUCTIONS

Make sure fuel valve is ON.

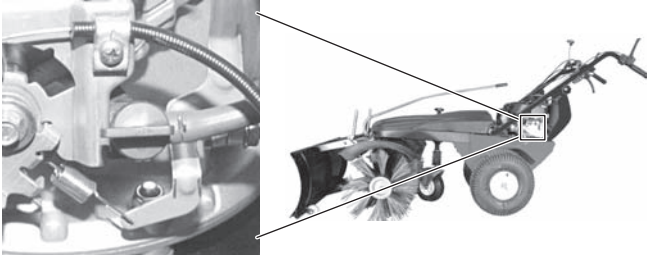

Pull starter coil. Stand behind the handlebars. Do not press any levers.



## Shutting Down the Motor

Close throttle.



Close fuel valve.

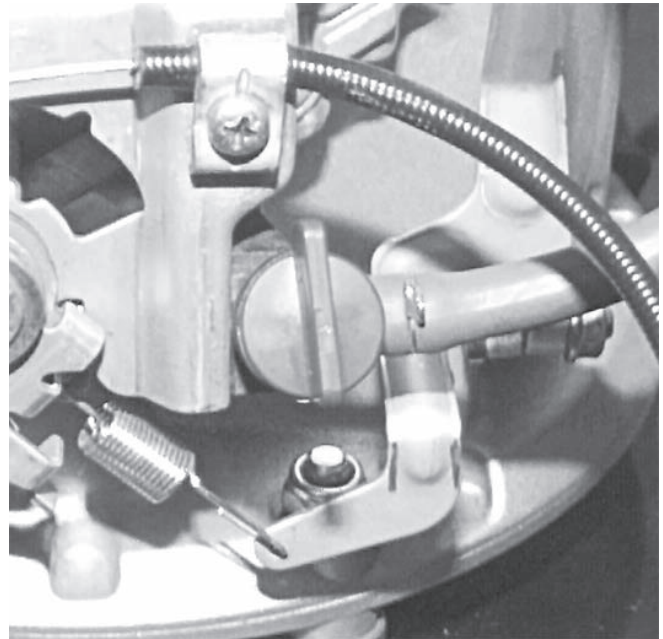

# OPERATING INSTRUCTIONS

## ADJUSTING HANDLEBAR HEIGHT

There are seven settings for adjusting the handlebar height.



Loosen the knob on both sides and choose the desired position



You can fold the handlebar forward to save space when storing.



## TRANSPORT

Use a ratchet strap around front and around rear axle when transporting.



Always use two straps on the rear axle; one on each side.

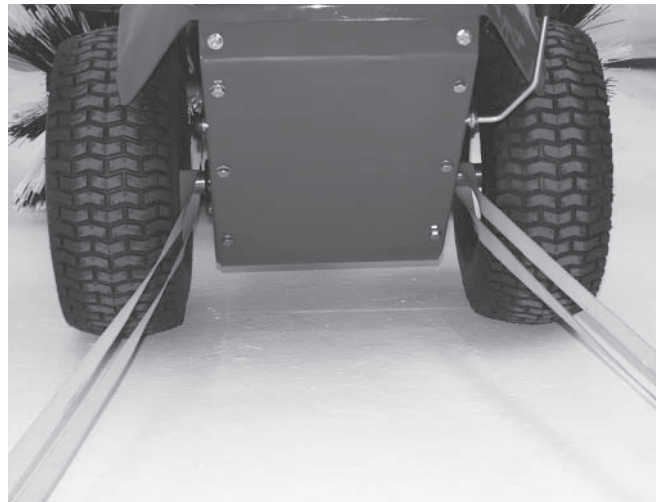

# OPERATING INSTRUCTIONS

## ADJUSTING EJECTION DIRECTION

There are five different settings available for the ejection direction.

Shown below: Forward ejection direction. The swept material will heap up in front of the brushes. You should give preference to angled brush settings.

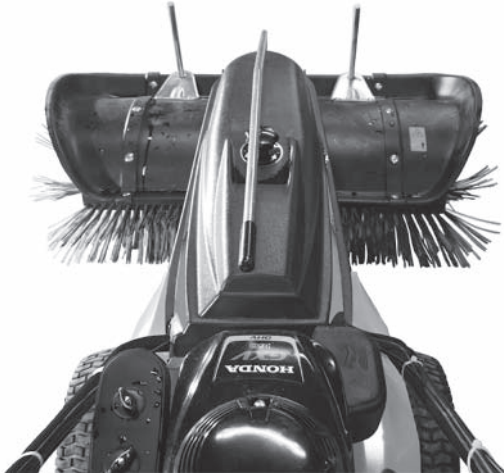

Shown below: Material will be ejected to the left.



If you use a plow, an angled direction must be used. Shown below: Ejection to the left.



To adjust brush angle: Lift the lever; Turn the brush in the desired direction; Release the lever and ensure the lever is latched in place.

With an angled setting, the material will be swept to one side.

Shown below: Material will be ejected to the right.



A sideways setting is recommended if using the optional debris collector. This will allow sweeping against a wall or curb. (Debris collector box is an optional accessory).

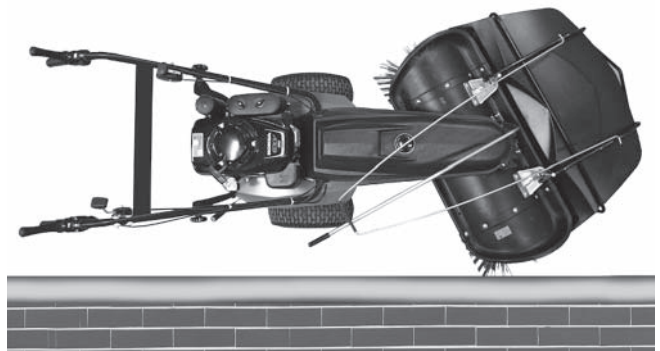

# OPERATING INSTRUCTIONS

## ADJUSTING BRUSH PRESSURE

The brush height can be adjusted in fine increments by adjusting the height of the support wheel.



The adjustment knob is located above the support wheel.



Lower the brush by turning the knob in the direction of the "minus" arrow until it just touches the floor. Turn the knob three more turns and the brush height is just right for sweeping.



Turn clockwise (+): Raise brush

Turn counter-clockwise (-): Lower brush



---

**IMPORTANT:** If the brushes are heavily worn, or if you are brushing cobblestones or brick pavers, lower the brush one more turn.

---

---

**NOTE:** If the brush pressure is too heavy, the cleaning effect is decreased because the brush fibers are bent too much. If you do not intend to use the rotary broom for a long period of time, release the pressure on the brush by raising the brush.

---

# OPERATING INSTRUCTIONS

---

## PLOW BLADE

To install the plow blade, lift the plow and hold it at an angle; slide it over the receiver bar and lower it into position.

1



2



3



An angled setting must be used when plowing snow.

The plow can be removed when clearing small amounts of snow – 1" or less (2.5 cm).

For snow over 1" (2.5 cm), use the plow blade.

The rotary broom can clear a maximum of 5-1/2" (14 cm) of snow in one pass. If snow is heavy, the capacity will be less.

See "Freewheel" section to adjust freewheel correctly for plowing snow.



# OPERATING INSTRUCTIONS

## DEBRIS COLLECTOR BOX (Optional Accessory)

### Rotary Broom with Debris Collector Box

Mount as shown below, paying attention to the alignment with brush hood.

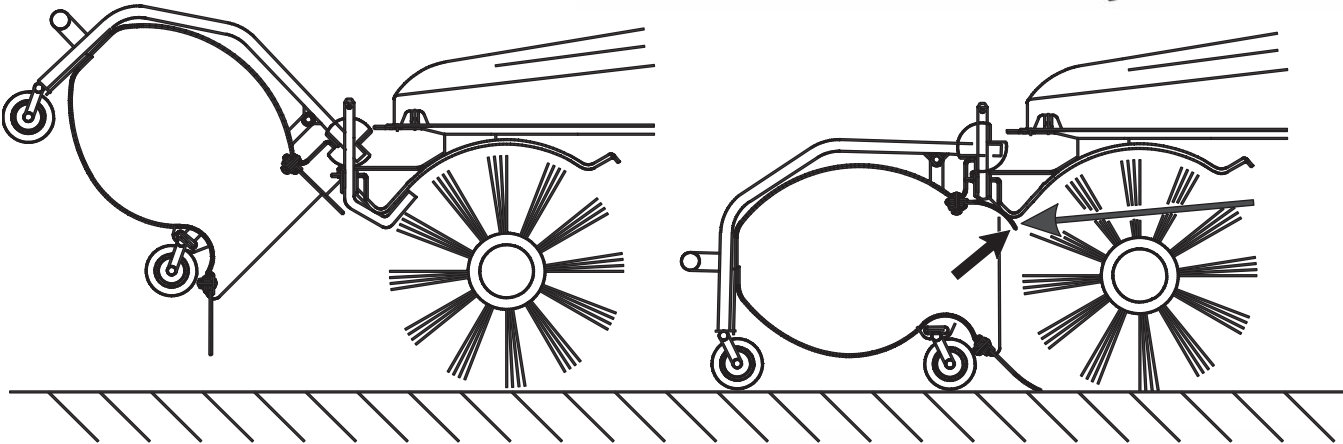

To dump the debris, simply pull the handle from the operating position so the debris can fall out.



To dump the debris into a separate container, remove the debris collector box from the sweeper and use the handle to tow it to your other container.



# MAINTENANCE

---

## OIL AND GAS

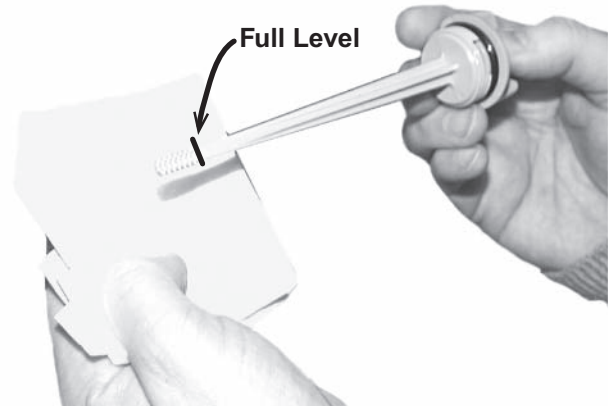
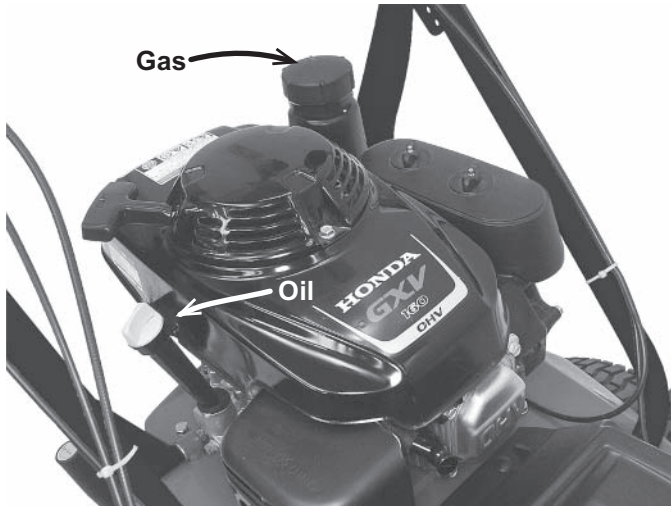

### Capacities:

Oil: 20 oz (0.6 L)

Gasoline: 1.5 qt (3 L)

Use 86 octane or higher unleaded gasoline.

1. Remove oil cap; wipe dipstick clean.
2. Replace dipstick in the oil filler neck; do not screw down.
3. Remove dipstick; check oil level. The oil should be up to the upper marking.
4. If oil level is low, fill up to the upper marking on the dipstick with the recommended oil (see Honda® Owner's Manual).
5. See marking on the dipstick for fill level.

# MAINTENANCE

---

## TIRE PRESSURE

---

**IMPORTANT:** If the tire pressure is too low, the inner tube will rub against the wheel and be damaged. Over-inflation can cause the tire to burst. Check the tire pressure for both the support and drive wheels regularly.

---

Unscrew the valve cap and use a tire inflation device to check or inflate the tire as necessary. Always replace the valve cap when you have finished inflating.

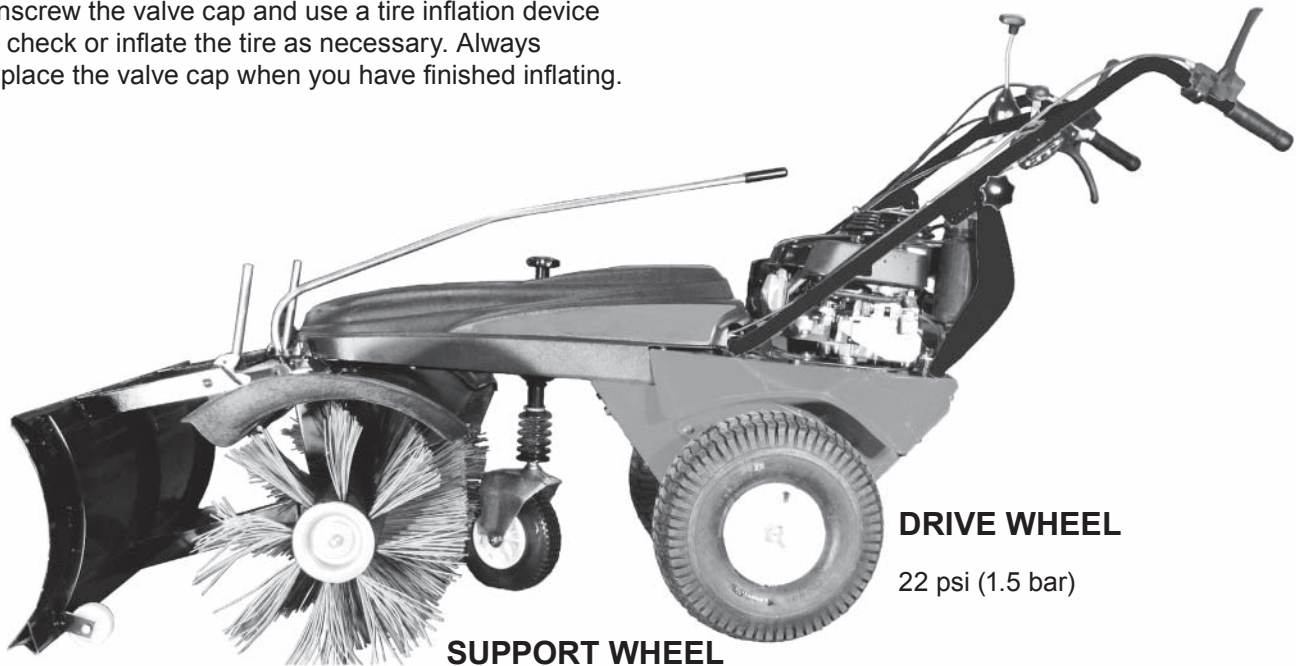

**SUPPORT WHEEL**

30 psi (2 bar)

On rough surfaces:

22 psi (1.5 bar)

**DRIVE WHEEL**

22 psi (1.5 bar)

# MAINTENANCE

## ADJUSTING CONTROL CABLES

**IMPORTANT:** It may be necessary to reset the cables after machine has been operating for a few hours.

Loosen the top nut with a 10 mm wrench.

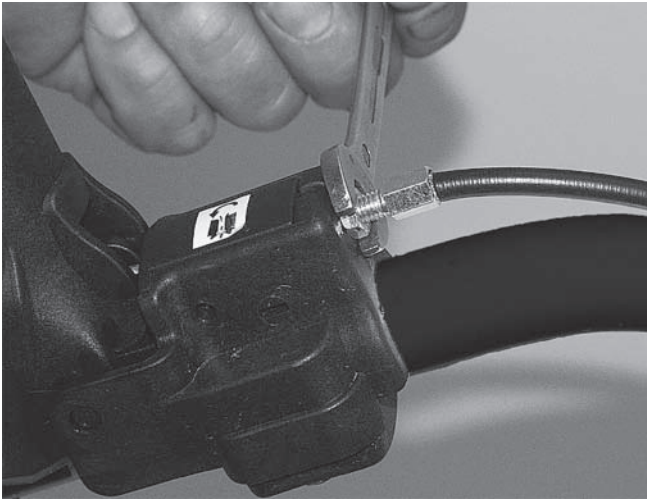

Tighten the nut. Check the adjustment by pressing the lever down.

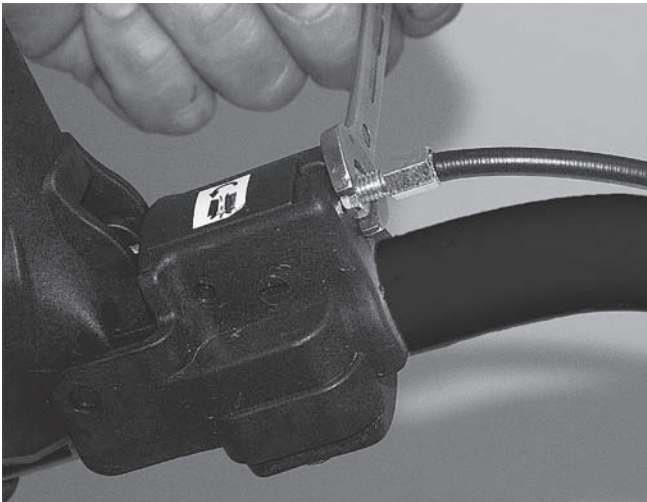

## Reverse Lever:

There should be about 3-1/8" (80 mm) of space between the handlebar and lever when there starts to be a resistance to the lever.

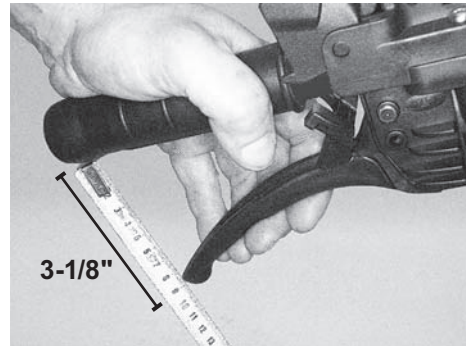

Turn the throttle cable the desired direction using an 8 mm wrench.

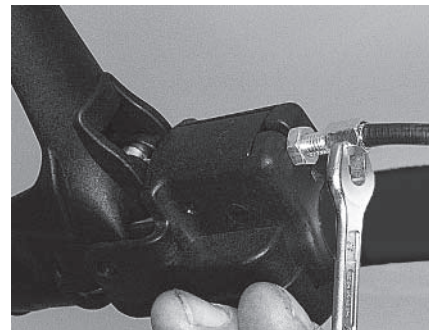

## Brush Drive and Forward Levers:

There should be about 5-1/2" (140 mm) of space between the handlebar and lever when there starts to be a resistance to the lever.

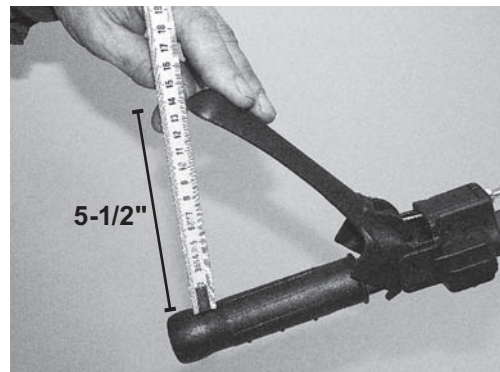

# MAINTENANCE

## REPLACING/CHANGING THE BRUSHES

**IMPORTANT:** Check the brushes after every 20 hours use. The brushes must be replaced if you are no longer satisfied with the brushing result, or if the brush diameter is below 8-5/8" (22 mm).

Loosen the nut on the axle. Use two 19 mm wrenches.



Remove the axle with the right brush.



**If replacing the multi-purpose brushes, or changing to them:** The black row of bristles must touch the ground before the white row when the brush rotates.

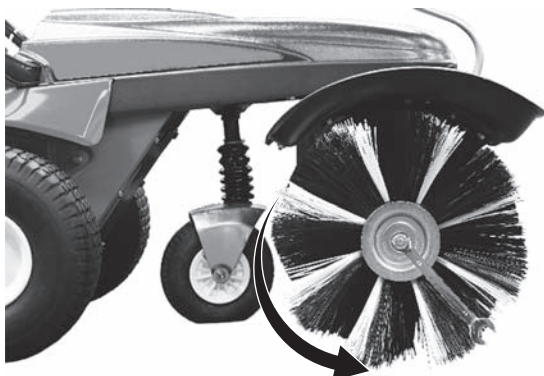

Remove the left brush.

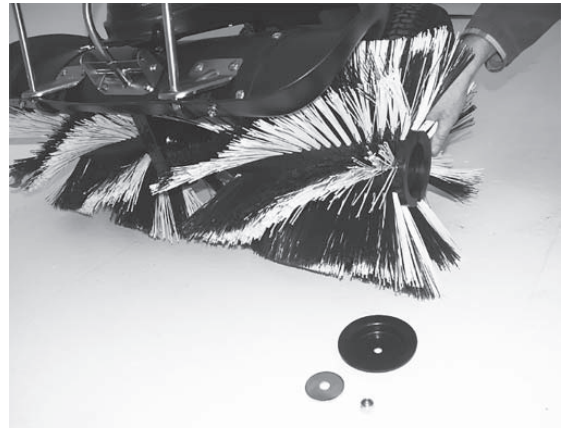

Parts after disassembly.

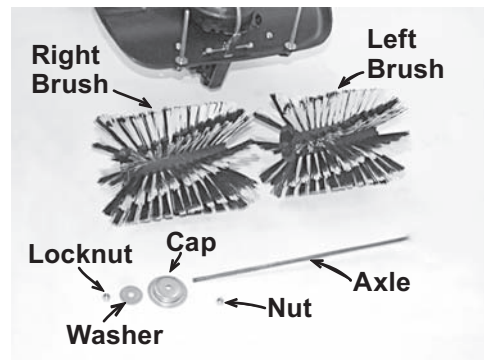

**If replacing the snow brushes (standard), or changing them:** The rows must curve upward from the left.



**NOTE:** Multi-purpose bristle shown for clarity.

Refer to the Installations Instructions for installing the new brushes.

# MAINTENANCE

| MAINTENANCE PLAN/<br>CLEANING                          | Before<br>every<br>use | After the following operating hours: |    |    |    |     | After 3<br>month<br>min. | At least<br>annually | After<br>every<br>cleaning |
|--|------------------------|--------------------------------------|----|----|----|-----|--------------------------|----------------------|----------------------------|
|  |                        | 5                                    | 10 | 25 | 50 | 100 |                          |                      |                            |
| Check screws and nuts                                  |                        |                                      | C  |    |    |     |                          |                      |                            |
| Check motor oil level, refill if necessary             | C                      |                                      |    |    |    |     |                          |                      |                            |
| First motor oil change                                 |                        | S                                    |    |    |    |     |                          |                      |                            |
| All further motor oil changes                          |                        |                                      |    |    | S  |     | S                        |                      |                            |
| Check air filter                                       | C                      |                                      |    |    |    |     |                          |                      |                            |
| Clean air filter element, earlier if necessary         |                        |                                      |    | M  |    | M   |                          |                      |                            |
| Replace air filter element, earlier if necessary       |                        |                                      |    |    | M  |     |                          |                      |                            |
| Replace fuel hoses                                     |                        |                                      |    |    |    |     | S<br>(2 years)           |                      |                            |
| Clean cool air screen                                  | M                      |                                      |    |    |    |     |                          |                      |                            |
| Clean baffle plate, cooling ribs, earlier if necessary |                        |                                      |    |    |    | S   |                          |                      |                            |
| Clean spark plugs, adjust gap                          |                        |                                      |    |    | S  |     |                          |                      |                            |
| Replace spark plugs                                    |                        |                                      |    |    |    | S   |                          |                      |                            |
| Clean exhaust  |                        | M                                    |    |    |    |     |                          |                      |                            |
| Lubricate all moving parts                             |                        |                                      |    |    |    |     | M                        | M                    |                            |
| Check hand lever play setting                          | C                      |                                      |    |    |    |     |                          |                      |                            |
| Check brush wear, earlier if necessary                 |                        |                                      |    | C  |    |     |                          |                      |                            |
| Stretch chain drive                                    |                        |                                      | C  | S  |    |     |                          |                      |                            |

S = Maintenance by Specialist      C = Check by Operator      M = Maintenance by Operator

**NOTE: Store the machine properly. Contact the local dealer for suitable storage practices in your geographic locations.**

## CLEANING

To keep your rotary broom in good condition, clean it regularly.

Remove loose dirt or dust with a car wash brush. Wash plastic surfaces with water and soap. Use normal car cleaning soap. Rinse off all cleaners thoroughly with clean water.

To give plastic parts a gloss finish, use a plastics care product.

Observe the instructions on the cleaning solution package.

Use glycerine as a corrosion protection for heavily soiled parts.

Do not use pressure washers. The high pressure may force water into bearings, seals, and the motor, causing damage.

# TROUBLESHOOTING

| FAULT  | POSSIBLE CAUSE   | FAULT REMEDY  |
|--|--|---|
| Motor will not start                           | Fuel tank empty  | Fill fuel tank  |
|  | Throttle lever not set to choke when motor is cold                       | Set throttle lever to choke                             |
|  | Spark plug leads not connected   | Connect spark plug leads                                |
|  | Fuel line blocked  | Send fuel line to workshop for cleaning                 |
|  | Motor receiving wrong air due to loose carburetor                        | Tighten fixing screws                                   |
|  | Fuel valve closed on Honda® motor  | Open fuel valve on Honda motor                          |
| Motor will not start;<br>gasoline smell        | Motor is receiving too much fuel   | Set throttle lever to full speed, not to choke          |
|  | Air filter dirty   | Clean air filter  |
| Motor running badly;<br>misfires               | Motor running with choke activated                                       | Move throttle lever out of choke position               |
|  | Spark plug leads loose   | Allow motor to cool and connect spark plug leads firmly |
|  | Air filter soiled  | Clean air filter  |
|  | Air bleed hole in fuel tank filler cap blocked                           | Replace fuel lines                                      |
|  | Fuel line blocked  | Run fuel system cleaner through tank of gas             |
|  | Carburetor not correctly adjusted  | Adjust carburetor/Send to dealer                        |
|  | Motor overheating  | See fault "Motor Overheating"                           |
| Motor misfires at high speed                   | Spark plug gap not correct   | Adjust spark plug gap/Send to dealer                    |
|  | Carburetor not correctly adjusted  | Adjust carburetor/Send to dealer                        |
| Motor overheating                              | Oil level too low  | Refill motor oil  |
|  | Air cooling system restricted  | Send to dealer/adjust air cooler grille & cooling ribs  |
|  | Air filter dirty   | Clean air filter  |
|  | Carburetor not correctly adjusted  | Adjust carburetor/Send to dealer                        |
| Motor often stops during turnover              | Throttle lever not set to choke when motor is cold                       | Set throttle lever to choke                             |
|  | Spark plug gap not correct   | Send carburetor to workshop for adjustment              |
|  | Air filter dirty   | Clean air filter  |
| Motor has lost power                           | Air filter soiled  | Clean air filter  |
|  | Compression too low  | Send to workshop for adjustment                         |
| Motor will not stop                            | Motor stop lever not correctly adjusted                                  | See Honda owner's manual/Send to dealer                 |
| Perpetual squeaking when brushes switched on   | Switch lever not completely pressed down                                 | Press switch lever completely down                      |
|  | Control cable not correctly adjusted                                     | Readjust brush control cable                            |
| Brushes do not turn, or stop moving under load | Switch lever not completely pressed down                                 | Press switch lever completely down                      |
|  | Control cable not correctly adjusted                                     | Readjust brush control cable                            |
|  | Toothed belts defective  | Send to dealer  |
| Machine will not move forward                  | Movement control cable not correctly adjusted                            | Re-adjust control cable                                 |
|  | Tension on toothed belt between motor and gearbox too low                | Send to dealer  |
| Machine leaves unbrushed central strip         | Ejection direction forward with worn brushes                             | Turn the ejection direction to the side                 |
|  | Brushes worn   | Replace brushes   |
| Bad brushing results                           | Brushes wrongly mounted  | Mount brushes correctly; observe working direction      |
|  | Brush pressure too high  | Readjust support wheel; Reduce brush pressure           |
|  | Brushes not genuine FISHER® parts  | Use only FISHER brushes                                 |
|  | Brushes not suitable for application                                     | Install FISHER multi-purpose brushes (PN 72258)         |
| Bad brushing results with debris collector box | Debris collector box not fitted correctly, sealing lip above brush cover | Mount swept material container correctly.               |



Fisher Engineering  
50 Gordon Drive  
Rockland, ME 04841-2139  
[www.fisherplows.com](http://www.fisherplows.com)

**A DIVISION OF FISHER, LLC**



*This product conforms to EU Machinery Directive 2006/42/EC.*

Copyright © 2017 Douglas Dynamics, LLC. All rights reserved. This material may not be reproduced or copied, in whole or in part, in any printed, mechanical, electronic, film or other distribution and storage media, without the written consent of Fisher Engineering. Authorization to photocopy items for internal or personal use by Fisher Engineering outlets or rotary broom owner is granted.

Fisher Engineering reserves the right under its product improvement policy to change construction or design details and furnish equipment when so altered without reference to illustrations or specifications used. Fisher Engineering may require or recommend optional equipment for rotary brooms. Fisher Engineering offers a limited warranty for all rotary broom and accessories. See separately printed page for this important information. The following are registered (®) trademarks of Douglas Dynamics, LLC: FISHER®.

**Printed in U.S.A.**