

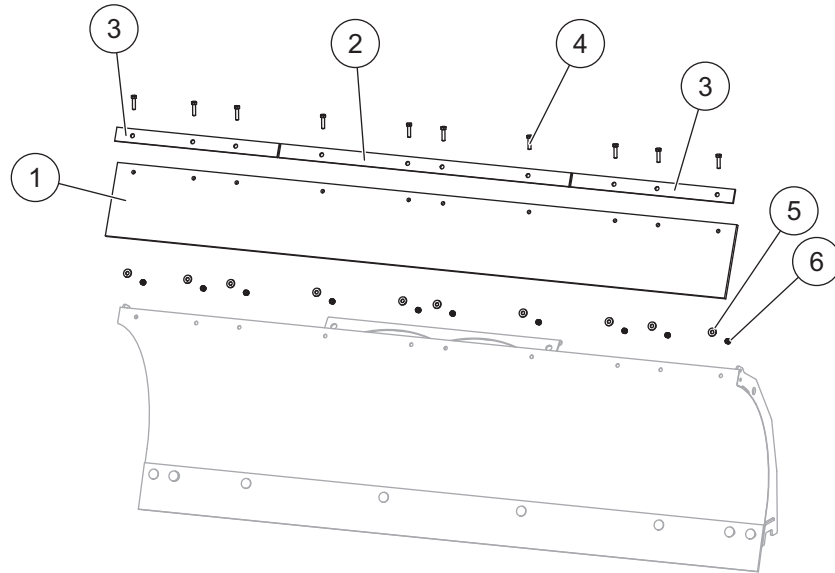

Rubber Deflector Kit

TRAILBLAZER™ UTV Straight Blade Snowplows

PARTS LIST



84985 TRAILBLAZER UTV Straight Blade Rubber Deflector Kit							
Item	Part	Qty	Description	Item	Part	Qty	Description
1	83207	1	TRAILBLAZER UTV Rubber Deflector	3	83205	2	Retainer Bar, Outside
2	84542	1	Retainer Bar, Center	ns	83644	1	Bolt Bag
83644 Bolt Bag							
4		10	5/16-18 x 1-1/4 Hex Cap Screw G5	6		10	5/16-18 Hex Locknut GB
5		10	5/16 Flat Washer Type A Wide				
ns = not shown				G = Grade			

⚠ WARNING

Do not exceed GVWR or GAWR, including blade and ballast.

⚠ CAUTION

Use standard methods and practices when attaching snowplow and installing accessories, including proper personal protective safety equipment.

⚠ CAUTION

Read this document before installing the rubber deflector kit.

⚠ CAUTION

See your FISHER® outlet/website for specific vehicle application recommendations before installation. The eMatch selection system has specific vehicle and snowplow requirements.

INSTALLATION INSTRUCTIONS

1. Park the vehicle on a smooth, level, hard surface, such as concrete. Lower the blade to the ground, and turn the control OFF. Disconnect the snowplow from the vehicle, or turn the vehicle ignition to the "OFF" position and remove the key.
2. Align the deflector on the blade, matching up the holes in the deflector with the holes in the moldboard.
3. Place the center retainer bar on top of the deflector, matching up the four holes in the hold-down with the four holes on the deflector. Install the center retainer using one 5/16" x 1-1/4" cap screw, one washer and one locknut for each hole, as shown. Torque fasteners to 17 ft-lb.

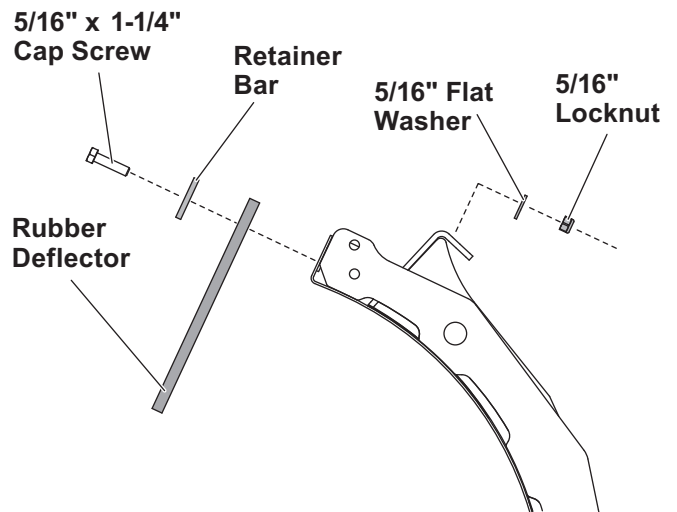

4. Repeat Steps 2 and 3 to install the outside retainer bars.

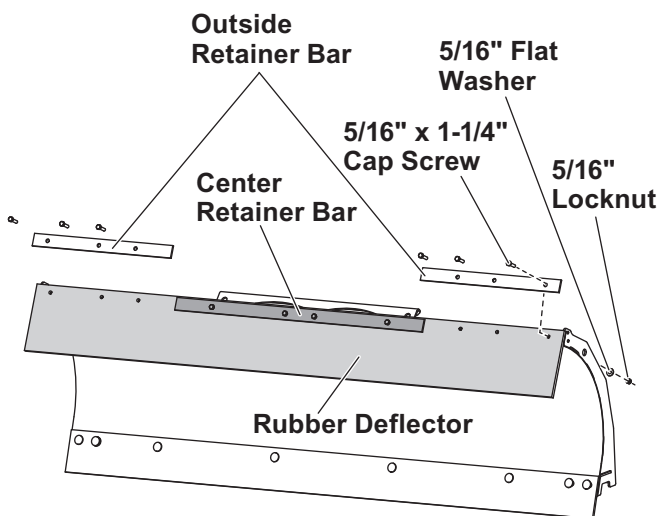

Copyright © 2016 Douglas Dynamics, LLC. All rights reserved. This material may not be reproduced or copied, in whole or in part, in any printed, mechanical, electronic, film or other distribution and storage media, without the written consent of Fisher Engineering. Authorization to photocopy items for internal or personal use by Fisher Engineering outlets or snowplow owner is granted.

Fisher Engineering reserves the right under its product improvement policy to change construction or design details and furnish equipment when so altered without reference to illustrations or specifications used. Fisher Engineering or the vehicle manufacturer may require or recommend optional equipment for snow removal. Do not exceed vehicle ratings with a snowplow. Fisher Engineering offers a limited warranty for all snowplows and accessories. See separately printed page for this important information. The following are registered (®) or unregistered (™) trademarks of Douglas Dynamics, LLC: FISHER®, TRAILBLAZER™.

Printed in U.S.A.