

July 15, 2004  
Lit. No. 94837



# UTS 696 Under Tailgate Spreader

## Owner's Manual



**⚠ CAUTION**

Read this manual before installing or operating the spreader.

This manual is for UTS 696 Under Tailgate Spreaders with serial numbers 0216 and higher.



# TABLE OF CONTENTS

---

PREFACE .....	1
SAFETY INFORMATION .....	2
Before You Begin .....	2
Lock Out Procedure Label and Warning/Caution Label .....	3
Torque Chart .....	3
LOADING .....	4
Certification .....	4
Material Weights .....	4
OPERATING THE SPREADER - CAB CONTROL .....	5
Cab Control Identification .....	5
Operating the Cab Control .....	5
OPERATING THE SPREADER .....	6
Dumping over the Spreader .....	6
Spreading .....	6
Clearing Jammed Auger/Emptying Material .....	6
Spread Patterns .....	7
Application Rates .....	8
HYDRAULIC CIRCUIT DIAGRAM .....	9
MAINTENANCE .....	10
Hydraulic Spreaders .....	10
Grease .....	10
After each use: .....	10
At the end of each season: .....	10
Troubleshooting .....	10



## PREFACE

---

This manual has been prepared to acquaint you with the safety information, operation and maintenance of your new spreader. Please read this manual carefully and follow all recommendations. This will help ensure profitable and trouble-free operation of your spreader. Keep this manual accessible. It is a handy reference in case minor service is required.

When service is necessary, bring your spreader to your local outlet. They know your spreader best and are interested in your complete satisfaction.

---

**NOTE: This spreader is designed to spread snow and ice control materials only. Do not use it for purposes other than those specified in this manual.**

---

# SAFETY INFORMATION

## **⚠ WARNING**

Indicates a potentially hazardous situation that, if not avoided, could result in death or serious personal injury.

## **⚠ CAUTION**

Indicates a situation that, if not avoided, could result in damage to product or property.

**NOTE:** Identifies tips, helpful hints and maintenance information the owner/operator should know.

### **Before You Begin**

- Park the vehicle on a level surface, place shift lever in PARK or NEUTRAL and set the parking brake. Turn off the engine and remove keys.

## **⚠ WARNING**

- Driver to keep bystanders minimum of 25 feet away from operating spreader.
- Before working with the spreader, secure all loose-fitting clothing and unrestrained hair.
- Before operating the spreader, verify all safety guards are in place.
- Before servicing the spreader, wait for conveyor and spinner to stop, then lock out power.
- Do not climb into or ride on spreader.

## **⚠ WARNING**

Overloading could result in an accident or damage. Do not exceed GVWR or GAWR ratings as found on the driver-side vehicle door cornerpost. See Loading Section to determine maximum volumes of spreading material.

## **⚠ WARNING**

Do not install the control for this product in the deployment path of an air bag. Refer to vehicle manufacturer's manual for air bag deployment area(s).

## **⚠ WARNING**

Hydraulic fluid under pressure could cause skin injection injury. If you are injured by hydraulic fluid, get medical attention immediately.

## **⚠ CAUTION**

If rear directional, CHMSL light or brake stoplights are obstructed by the spreader, the lights shall be relocated, or auxiliary directional or brake stoplights shall be installed.

## **⚠ CAUTION**

During the spreader installation we recommend the addition of an OSHA compliant Backup Alarm. This alarm is required for OSHA governed employers.

## **⚠ CAUTION**

- Do not operate a spreader in need of maintenance.
- Before operating the spreader, reassemble any parts or hardware removed for cleaning or adjusting.
- Before operating the spreader, remove materials such as cleaning rags, brushes, and hand tools from the spreader.
- Before operating the spreader, read the owner's manual.
- While operating the spreader, use auxiliary warning lights, except when prohibited by law.
- Tighten all fasteners according to the Torque Chart. Refer to Torque Chart for the recommended torque values.

## **⚠ CAUTION**

Disconnect hydraulic power and lock out auger before cleaning, servicing or performing maintenance.

## **⚠ CAUTION**

Do not leave unused material in hopper. Material can freeze or solidify, causing unit to not work properly. Empty and clean hopper after each use.

**NOTE:** Lubricate grease fittings after each use. Use good quality multi-purpose grease.

# SAFETY INFORMATION

Please become familiar with the Warning and Caution labels on the spreader!

## Lock Out Procedure Label

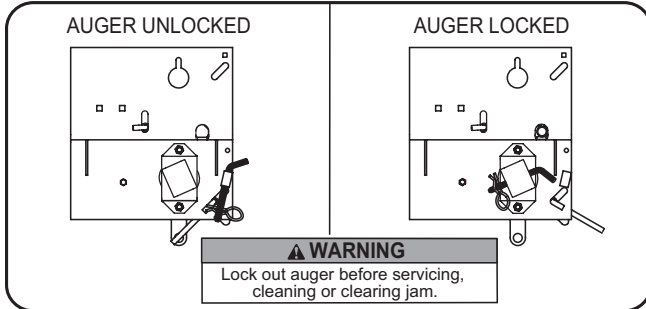

## TORQUE CHART

**CAUTION**

Read instructions before assembling. Fasteners should be finger tight until instructed to tighten according to the torque chart. Use standard methods and practices when attaching spreader including proper personal protective safety equipment.

Recommended Fastener Torque Chart (Ft.-Lb.)			
Size	SAE Grade 2	SAE Grade 5	SAE Grade 8
1/4-20	6	9	13
5/16-18	11	18	28
3/8-16	19	31	46
3/8-24	24	46	68
7/16-14	30	50	75
1/2-13	45	75	115
9/16-12	66	110	165
5/8-11	93	150	225
3/4-10	150	250	370
7/8-9	150	378	591
1-8	220	583	893

Metric Grade 8.8 (Ft.-Lb.)			
Size	Torque	Size	Torque
M 6	7	M 12	60
M 8	17	M 14	95
M 10	35	M 16	155

These torque values apply to fasteners except those noted in the instruction.

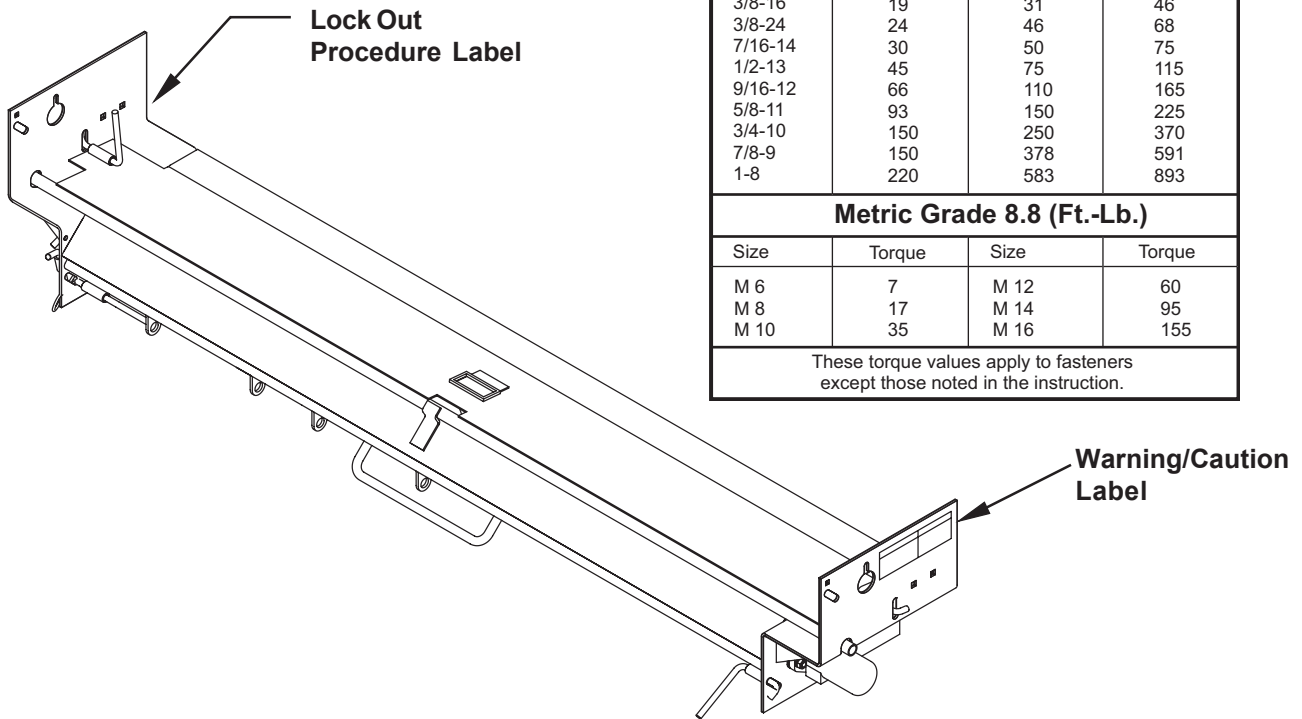

## Warning/Caution Label

<b>WARNING</b>	<b>CAUTION</b>
<ul style="list-style-type: none"> <li>• DO NOT EXCEED GVWR OR GAWR WITH SPREADER AND LOAD.</li> <li>• TURN SPREADER OFF BEFORE FILLING, ADJUSTING, OR CLEANING.</li> <li>• BYSTANDERS TO STAY A MINIMUM OF 25 FEET AWAY FROM OPERATING SPREADER.</li> <li>• DO NOT CLIMB OR RIDE ON SPREADER.</li> <li>• KEEP HANDS, FEET, CLOTHING AWAY FROM MOVING CONVEYOR AND SPINNER.</li> <li>• LOCK OUT AUGER BEFORE SERVICING, CLEANING OR CLEARING JAM.</li> </ul>	<ul style="list-style-type: none"> <li>• READ OWNER'S MANUAL BEFORE OPERATING OR SERVICING SPREADER.</li> <li>• EMPTY AND CLEAN SPREADER AFTER EVERY USE.</li> </ul>

# LOADING

---

This Manual covers vehicles which have been recommended for carrying the spreader. Please see your local dealer for proper vehicle applications.

## **⚠ WARNING**

Overloading could result in an accident or damage. Do not exceed GVWR or GAWR as found on the driver-side vehicle door cornerpost.

## Certification

### **⚠ WARNING**

New untitled vehicle installation of a spreader requires National Highway Traffic Safety Administration altered vehicle certification labeling. Installer to verify that struck load of snow or ice control material does not exceed GVWR or GAWR rating label and complies with FMVSS.

## Material Weights

### **⚠ CAUTION**

Read and adhere to manufacturer's ice control package labeling including Material Safety Data Sheet requirements.

<b>Material</b>	<b>Density</b> (lb. per cubic yd.)
Fine Salt - Dry	1,350
Coarse Salt - Dry	1,215
Coarse Sand - Dry	2,700
Coarse Sand - Wet	3,240
Cinders	1,080
60% Sand/40% Salt	2,106



# OPERATING THE SPREADER - CAB CONTROL

## Cab Control Identification

Typical Spreader Control Valve (Sold as an accessory)

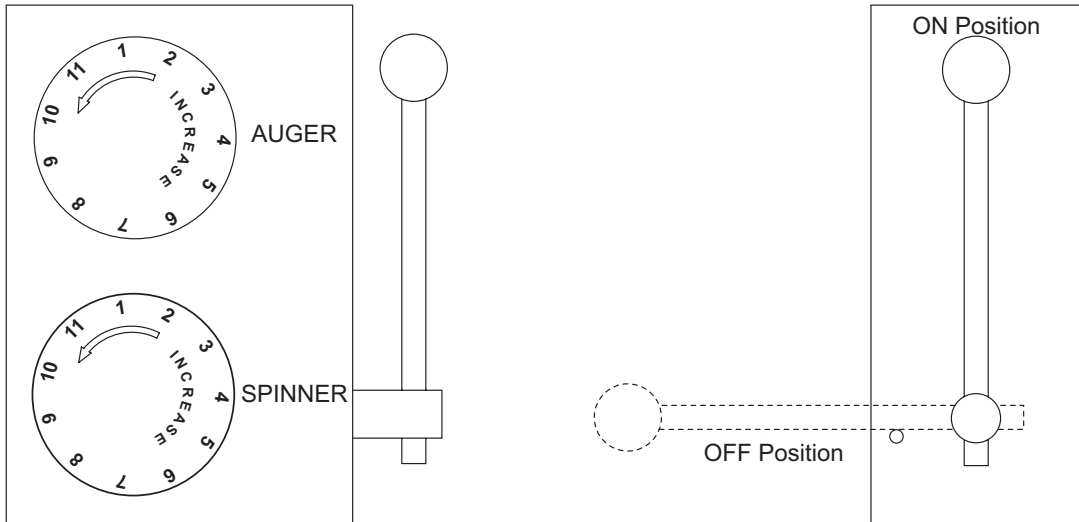

### ⚠ WARNING

- Driver to keep bystanders minimum of 25 feet away from operating spreader.
- Before working with the spreader, secure all loose-fitting clothing and unrestrained hair.
- Before operating the spreader, verify all safety guards are in place.
- Before servicing the spreader, wait for conveyor and spinner to stop, then lock out power.
- Do not climb into or ride on spreader.

### ⚠ CAUTION

- Do not operate a spreader in need of maintenance.
- Before operating the spreader, reassemble any parts or hardware removed for cleaning or adjusting.
- Before operating the spreader, remove materials such as cleaning rags, brushes, and hand tools from the spreader.
- Before operating the spreader, read the owner's manual.
- While operating the spreader, use auxiliary warning lights, except when prohibited by law.
- Tighten all fasteners according to the Torque Chart. Refer to Torque Chart for the recommended torque values.

## Operating the Cab Control

1. Engage the hydraulic system with the spreader lever in the "OFF" position.
2. To turn the spreader on, move the lever to the "ON" position. The spinner and auger should begin to turn.
3. The spinner and auger speeds are independently adjusted by rotating the detented adjustment knobs. The knobs can be adjusted either during operation or with lever in the "OFF" position. These speed settings will be maintained when the lever is placed in the "OFF" position.

# OPERATING THE SPREADER

## Dumping Over the Spreader

1. The trough lid should be in the down position and locked.

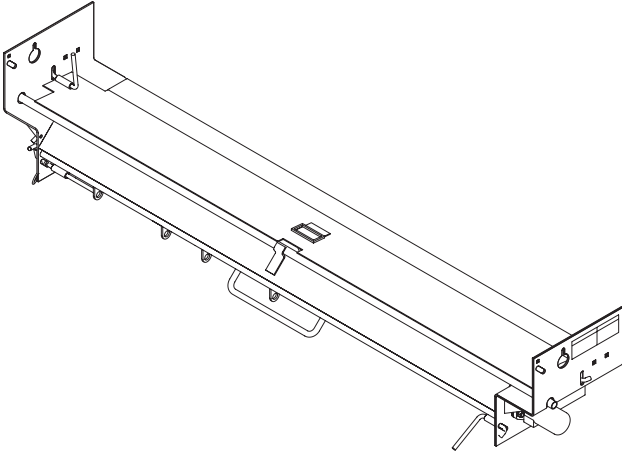

2. Open the dump body tailgate and raise the dump body.

## Spreading

1. The trough lid should be in the up position and locked.

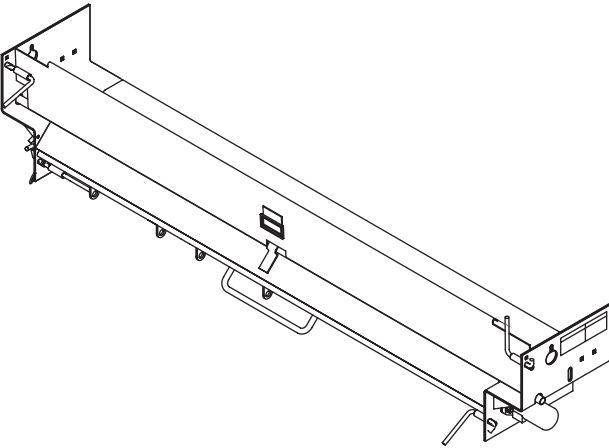

### **⚠ WARNING**

**Never climb into or ride on spreader or dump body.**

2. Adjust dump body tailgate chains such that the dump body tailgate does not contact the spreader lid.
3. Turn the spreader on.
4. Open the tailgate latch and raise the dump body to allow material to flow into the auger.

## Clearing Jammed Auger/Emptying Material

### **⚠ WARNING**

**Never climb into or ride on spreader or dump body.**

### **⚠ WARNING**

**Never attempt to clear a jammed unit without shutting off and locking out auger and power.**

1. Turn off and lock out the power source(s) before leaving the cab of the truck. This includes but is not limited to turning off the Power Take-Off and/or truck engine, removing the keys, disconnecting the hydraulic hoses and locking out the auger.
2. The spreader is equipped with a bottom cleanout door. To open the cleanout door, remove lock out pins and place through the lock out plates and auger shaft, rotate the handles of the cleanout door to align the latch hooks with the slots. Next, slide the latches toward the center. This will release the cleanout door allowing it to rotate down and toward the truck, exposing the auger for cleaning.

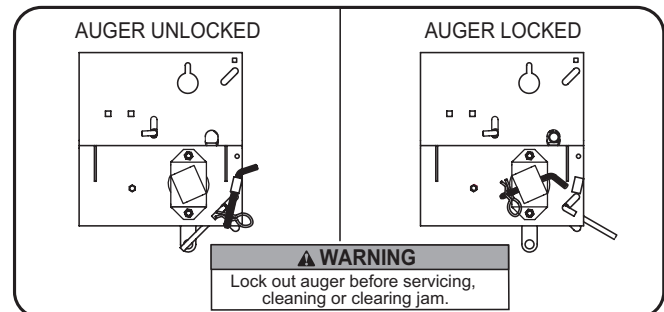

3. Reverse Step 2 for closing the cleanout door and resuming spreading.

# OPERATING THE SPREADER

---

## Spread Patterns

These figures are as viewed from the top of the spinner looking down.

### Deflector Effect

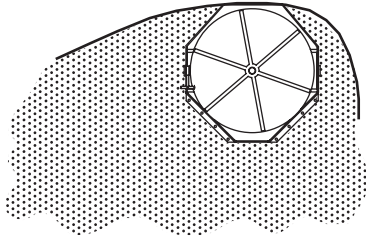

**Driver side open**

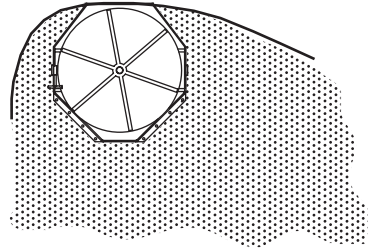

**Passenger side open**

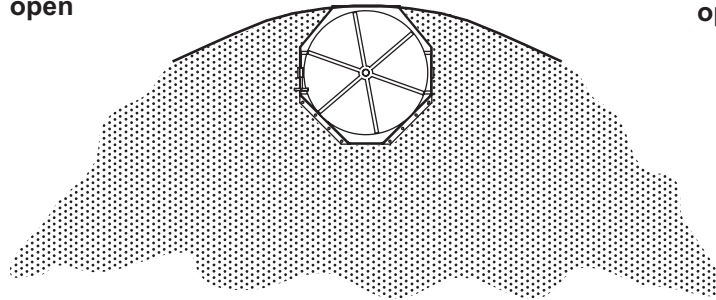

**Both sides open**

### Spinner Assembly Effect

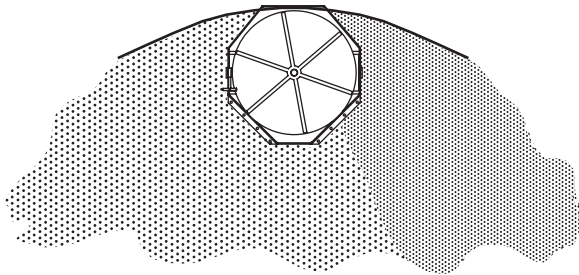

**Spinner Assembly moved to passenger side  
Heavy on passenger side.**

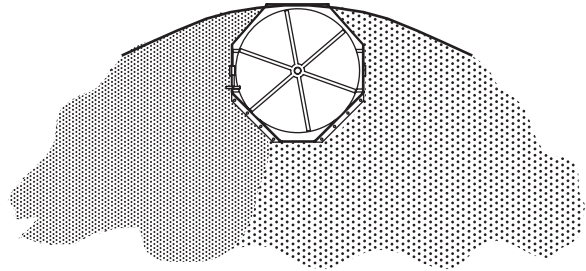

**Spinner Assembly moved to driver side  
Heavy on driver side.**

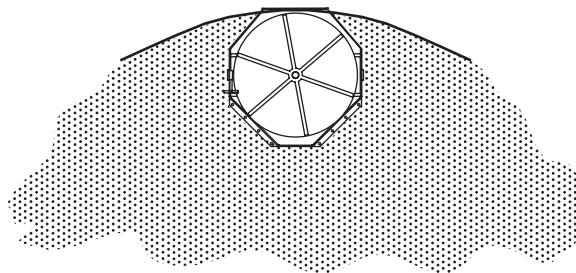

**Spinner Assembly Centered**

## OPERATING THE SPREADER

### Application Rates

Valve Max 15 gmp		Motor Displacement	cu ft/rev 0.1286	Sand	Salt/Sand	Fine Salt	Coarse Salt
gpm	valve setting	motor/auger rpm	cu ft/min	lb/cu ft 125 lb/min	lb/cu ft 100 lb/min	lb/cu ft 50 lb/min	lb/cu ft 45 lb/min
0.00	0	0	0.00	0.0	0.0	0.0	0.0
1.36	1	17.6	2.26	282.9	226.3	113.2	101.8
2.73	2	35.2	4.53	565.8	452.6	226.3	203.7
4.09	3	52.8	6.79	848.7	678.9	339.5	305.5
5.45	4	70.4	9.05	1131.5	905.2	452.6	407.4
6.82	5	88.0	11.32	1414.4	1131.5	565.8	509.2
8.18	6	105.6	13.58	1697.3	1357.8	678.9	611.0
9.55	7	123.2	15.84	1980.2	1584.2	792.1	712.9
10.91	8	140.8	18.10	2263.1	1810.5	905.2	814.7
12.27	9	158.4	20.37	2546.0	2036.8	1018.4	916.5
13.64	10	176.0	22.63	2828.8	2263.1	1131.5	1018.4
15.00	11	193.6	24.89	3111.7	2489.4	1244.7	1120.2

Valve Max 10 gpm		Motor Displacement
gpm	valve setting	spinner rpm
0.00	0	0
0.91	1	72
1.82	2	145
2.73	3	217
3.64	4	290
4.55	5	362
5.45	6	434
6.36	7	507
7.27	8	579
8.18	9	652
9.09	10	724
10.00	11	797

# HYDRAULIC CIRCUIT DIAGRAM

## Typical Hydraulic Circuit Dedicated Fixed Displacement Pump

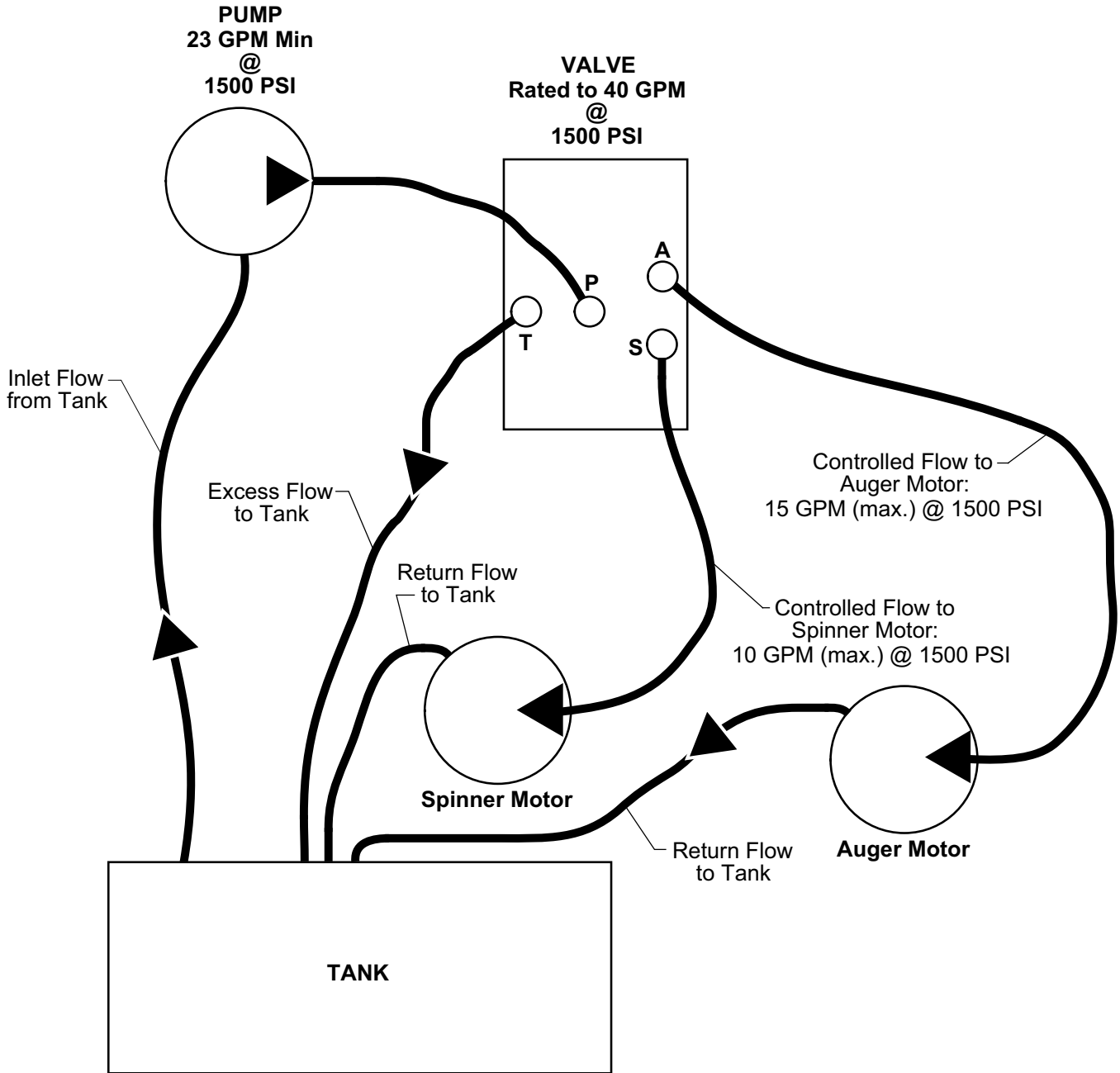

# MAINTENANCE

## Hydraulic Spreaders

1. Check hydraulic fluid level before every use. Add fluid as required.
  2. Periodically inspect the hoses and fittings for damage and possible leaks.
  3. Change the hydraulic fluid after the first 50 hours of operation of a new unit.
  4. Reservoir should be drained through the drain plug only, NOT through the suction outlet.
- Flush and refill reservoir annually, or sooner if fluid shows signs of break-down or contamination.
  - The use of proper hydraulic fluid in the system is critical to satisfactory performance. Only clean, new hydraulic fluid, of the proper type and viscosity as recommended by the pump manufacturer, should be used.
  - Keep all hydraulic fluids in original containers. Use only clean measuring containers and funnels when pouring fluids. Keep all containers closed when not in use.

## Grease

- After every 10 hours of operation, grease the bearings on the auger shaft.

### CAUTION

**Always disconnect hydraulic power and lock out auger before servicing or performing any maintenance.**

To keep your spreader functioning properly, observe the following recommendations:

### After each use:

- Wash out hopper and rinse off all external surfaces.
- Lubricate all grease fittings.

### At the end of each season:

- Wash out hopper and all external surfaces.
- Lubricate all grease fittings.
- Oil or paint all bare metal surfaces.

## Troubleshooting

PROBLEM	CORRECTION
1. Unit speed does not increase with the dial setting.	A. Increase the truck engine speed. B. Check condition of pump. C. Check for adequate PTO percent.
2. Unit stalls under load.	Check circuit pressure. 900-1200 PSI maximum with relief valve lifting at 1500 PSI.
3. Unit speed fluctuates momentarily when control is first turned on.	A. Oil is cold. Wait until oil has warmed up. B. Change to lighter weight oil.
4. Pump blows seals at start up.	Pump installed backwards. Replace seals and reverse pump in driveline. (Note arrow on pump.)





FISHER ENGINEERING  
P.O. BOX 529  
ROCKLAND, MAINE 04841



**A DIVISION OF DOUGLAS DYNAMICS, L.L.C.**

Copyright © 2004 Douglas Dynamics, L.L.C. All rights reserved. This material may not be reproduced or copied, in whole or in part, in any printed, mechanical, electronic, film or other distribution and storage media, without the written consent of Fisher Engineering. Authorization to photocopy items for internal or personal use by Fisher Engineering outlets or spreader owner is granted.

Fisher Engineering reserves the right under its product improvement policy to change construction or design details and furnish equipment when so altered without reference to illustrations or specifications used. Fisher Engineering and the vehicle manufacturer may require and/or recommend optional equipment for spreaders. Do not exceed vehicle ratings with a spreader. Fisher Engineering offers a limited warranty for all spreaders and accessories. See separately printed page for this important information. The following is a registered (®) trademark of Douglas Dynamics, L.L.C.: FISHER®.

**Printed in U.S.A.**

**July 15, 2004**

**Lit. No. 94837**